

VEICHI

Manual

AC100 Series Frequency Inverter

VEICHI

Shenzhen Veichi Electric Co., Ltd.

Address: Block C, Wentao Science and Technology Park, Shiyan Yingrenshi
Community, Baoan District, Shenzhen, China

Phone: +86-0755-29685610, 29685611, 29685612

Fax: +86-0755-29685615

Suzhou Veichi Electric Equipment Technology Co., Ltd.

Address: No.111 Wusongjiang Avenue, Guoxiang Street, Wuzhong District,
Suzhou, China

Website: www.veichi.com



Version:2016 V1.0
Shenzhen Veichi Electric Co., Ltd all rights
reserved, subject to change without notice.

Contents

Chapter 1 Overview	1
1.1 Safety Precautions.....	1
1.2 Technical Criterion	4
1.3 Specification of Expansion Card	7
Chapter 2 Before Use	8
2.1 Purchase Inspection.....	8
2.2 Nameplate	8
2.3 Standard Models and Rated Parameters.....	9
Chapter 3 Installation and Wiring	10
3.1 Safety Precautions.....	10
3.2 Dealing Methods for Inverter after Long-term Storage	11
3.3 Stable Running Environment for Inverter.....	11
3.4 EMI Protection.....	12
3.5 Machinery Installation.....	15
3.6 Electrical Installation.....	23
Chapter 4 Basic Operation and Trial Run	37
4.1 Safety Precautions.....	37
4.2 Keyboard Layout and Functions Specification.....	38
4.3 Basic Operation.....	41
4.4 LED Keyboard Operation Specification.....	43
4.5 Trial Run.....	48
Chapter 5 Fault Diagnoses and Processing	56
5.1 Fault Types.....	56
5.2 Fault Information and Details	56
5.3 Fault Diagnoses and Treatment Measures	61
Chapter 6 Regular Inspection and Maintenance	67
6.1 Safety Precautions.....	67
6.2 Inspection.....	67
6.3 Maintenance.....	69
Chapter 7 Peripherals and Options	72
7.1 Safety Precautions.....	72
7.2 Peripherals.....	72
7.3 The Use of Peripherals	74
Chapter 8 Function Parameter Specification	77
8.1 Basic Parameters	77
8.2 Running Control Parameter.....	87
8.3 Quantum Digital Terminal Parameter	93
8.4 Analog Terminal Parameter.....	108

8.5 Keyboard and Display Parameters	113
8.6 Motor Parameters	117
8.7 VC Control Parameter	119
8.8 Torque Control Parameters	123
8.9 V/F Control Parameters	125
8.10 Malfunction and Protection Parameters	128
8.11 PID Parameters	133
8.12 Multi-step, PLC Function and Swing Frequency Parameters.....	138
8.13 Communication Control Function Parameters	143
Chapter 9 Appendix.....	149
9.1 Appendix 1: Function Parameter Table	149
9.2 Appendix 2: RS485 Communication Protocol	188
9.3 Appendix 3: PG Card Manual.....	196
9.4 Appendix 4: Profibus-DPcard Manual	204
9.5 Appendix 5:LCD Keyboard	206
9.6 Appendix 6: CANopen Card Manual	210

Chapter 1 Overview





Thanks for using AC100 high-performance VC frequency inverter produced by Shenzhen Veichi Electric Co., Ltd. This manual explains the proper way of using the product. Please read carefully (installation, wiring, operation, maintenance, checking, etc) before use.

1.1 Safety Precautions

To ensure safe, reliable and rational use of this product, please fully understand the safety precautions described in this manual before use.

Warning Signs and Meanings

This manual uses the following marks to indicate the importance of security. If these precautions are not followed, accidents such as personal injury, damage of the product and associated systems might occur.

	Danger: Wrong operation may cause death or major accident.
	Warning: Wrong operation may cause death or major accident.
	Caution: Wrong operation may cause minor injury.
	Important: Wrong operation may cause damage to the inverter and related system

Warning Signs Position

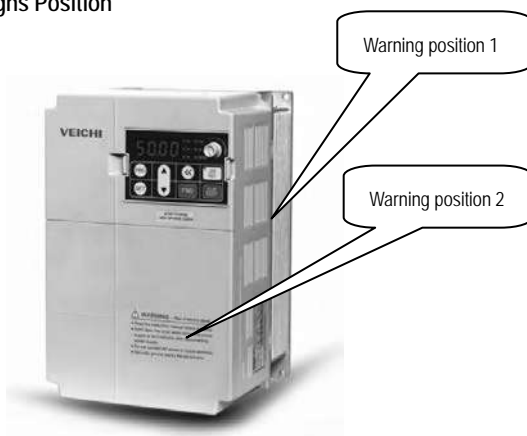

Drawing 1: Warning positions on crust of AC100 series inverter

Operation Qualification



All the products must be performed by trained professionals for installation, wiring, operation, maintenance and other operations. The "trained professionals" referred in this manual must undergo professional training, being familiar with the installation, wiring, operation and maintenance of the equipment and must be able to handle with all kinds of arising emergencies.

Safety Guidance



Safety rules and warning signs are set for users' safety and to prevent personal injury, damage of product and associated systems; to ensure safe, reliable and rational use of this product, please fully understand the safety precautions described in this manual before use.

Safety rules and warning signs are divided into the following categories: routine guidance, transportation and storage guidance, installation guidance wiring, operation and maintenance guidance, as well as dismantlement and disposal guidance



● Routine Guidance

	<ul style="list-style-type: none"> ● This product contains dangerous voltage and it controls the movement mechanism with potential danger; there might be accidents like personal injury and damage to the product and associated systems if requirements in this manual are not followed. ● Only trained personnel should operate this product, and before using the product in this manual the personnel should be familiar with all safety instructions and regulations of the operation; proper operation and maintenance are the key to achieve security and stability of the product. ● No wiring when power on. Otherwise, there might be danger of electric shock; when operating wiring, inspection, maintenance and other operations, please turn off the power of all related equipment and make sure the main circuit DC voltage has dropped to security level, and wait for five minutes before any relevant job.
	<ul style="list-style-type: none"> ● Away from children and public. ● This product could only be used in special areas specified by the manufacturer and should not be used in fields like emergency, rescue, marine, medical, aerospace, nuclear facilities without permission. ● Unauthorized alteration or use of accessories not sold or recommended by the manufacturer may cause a malfunction.
	<ul style="list-style-type: none"> ● Please make sure this manual is in the final user's hand before use. ● Before installation and debugging please carefully read and totally understand these safety regulation and warning signs.

● Transportation and Storage Guidance

	<ul style="list-style-type: none"> ● Correct transportation, storage, installation, and careful operation and maintenance are essential for the safe operation of the inverter.
	<ul style="list-style-type: none"> ● In transport and store process, make sure the inverter is free from shock and vibration. It must be stored in places dry without corrosive air and conductive dust, and the temperature must be lower than 60°C.

● Installation and Wiring Guidance

	<ul style="list-style-type: none"> ● Only trained personnel can operate. ● Power lines, motor lines, control lines must be connected tightly, and the ground terminal must be grounded, and the grounding resistance must be less than 10Ω. ● Before opening the inverter panel, turn off the power of all related equipment, and make sure the main circuit DC voltage has dropped to a safe level, and wait five minutes before any relevant job. ● Human body electrostatic would seriously damage the inner sensitive components. Before operation, please follow ESD measures. Otherwise, there might be danger of inverter damage. ● The voltage of the inverter outputs in form of pulse wave, and if capacitor that improve power factor or varistor that is against thunder is installed on the output side, make sure to dismantle them or modify them to the input side of the inverter. ● No switch components such as breaker and contactor at the output side. (If there must be one, please make sure the output current is 0 while the switch acting).
	<ul style="list-style-type: none"> ● The power supply cable and motor cable specifications must satisfy all conditions in table 3-7 and table 3-8.

● Running Guidance

	<ul style="list-style-type: none"> ● Inverter runs at high voltage. So dangerous voltage is in some components inevitably. ● No matter where the fault is, there is danger of serious accident, even human body injury which means dangerous malfunction possibility. So there must be additional external preventing measures or other safety devices, such as independent current limiting switch, machinery fence and so on. ● In order to ensure that the motor overload protection can operate correctly, motor parameters must exactly match the motor in use.
---	---

● Maintenance Guidance

	<ul style="list-style-type: none"> ● Maintenance and service of this product can only be done by the service sectors or authorized service center of Veichi Electric Co., Ltd or professional person trained and authorized by Veichi. And these personnel should be familiar with the safety warnings and proposed operating essentials referred in this manual. ● Any defective components must be changed in time. ● Before opening the equipment, be sure to disconnect the power, and make sure the main circuit DC voltage has dropped to a safe level, and wait five minutes before any relevant job
---	--

● Dismantlement and Disposal Guidance

	<ul style="list-style-type: none"> ● The inverter's packaging is reusable, please keep the packaging for future use or please return it to the manufacturer. ● Dismantlement of metal components can be recycled. ● Some components such as electrolytic capacitor are harmful to the environment. Please dispose according to the requirements of environmental protection departments.
---	---

1.2 Technical Criterion

Items		Criterion
Power input	Voltage, frequency	Single-phase 220V 50 / 60Hz three-phase 380V 50 / 60Hz Three-phase 220V 50 / 60Hz three-phase 660V 50 / 60Hz
	Allowable fluctuations	Voltage fluctuation: 320V ~ 440V; Voltage unbalance rate: <3%; Frequency fluctuation: $\pm 5\%$ Distortion rate: meet IEC61800-2 requirements
	Closing inrush current	Lower than rated current
	Power factor	≥ 0.94 (with DC reactor)
	Inverter efficiency	$\geq 96\%$
Output	Output voltage	Under nominal conditions Output: 3 phase, 0 to the input voltage, the error
	Output frequency range	0 ~ 320 Hz (320 Hz or more can be factory customized)
	Output frequency accuracy	Error does not exceed 0.01Hz (digital setting) or 0.2% of maximum frequency (analog reference)
	Overload capacity	150% of rated current for 1 minute; 180% of rated current for 10 seconds; 200% of rated current for 0.5 seconds;
Main Control performance	Motor control mode	Induction motors: vector control without PG, PG vector control, VF control Permanent magnet synchronous: no PG vector control, vector control with PG
	Modulate mode	Optimization space vector PWM modulation, continuous adjustment, not continuous adjustment automatically switch
	Carrier frequency	0.6~15.0kHz, randomized carrier-wave
	Speed range	VC with PG: 1: 1000 VC without PG (asynchronous): 1: 100 VC without PG (synchronous): 1:50
	Steady speed accuracy	VC without PG (asynchronous and synchronous): $\leq 1\%$ rated synchronous speed VC with PG (asynchronous and synchronous): $\leq 0.02\%$ rated synchronous speed
	Starting torque	VC without PG (asynchronous): 0.5Hz provide 180% rated torque VC without PG (synchronous): 2Hz to provide 100% of the rated torque VC with PG (synchronous and asynchronous): 0Hz provide 200% of the rated torque
	Torque response	VC without PG (synchronous and asynchronous): $\leq 20\text{ms}$ VC with PG (synchronous and asynchronous): $\leq 10\text{ms}$
	Frequency accuracy	Digital setting: 0.01Hz; Analog setting: Maximum frequency $\times \pm 0.2\%$
	Frequency resolution	Digital setting: 0.01Hz; Analog setting: Maximum frequency $\times 0.05\%$
Basic functions	DC braking capacity	Starting frequency: 0.00~50.00Hz Braking time: 0.0~60.0s Braking current: 0.0~150.0% rated current

Torque upgrade capacitance	Auto torque upgrade 0.0%~100.0% Manual torque upgrade 0.0%~30.0%
V/F curve	VF linear curve, custom multi VF curve, square VF curve; VF power 1.1-1.9 arbitrary curve;
Acceleration/Deceleration curve	Two ways: one linear acceleration and deceleration, S-curve acceleration and deceleration; Four sets of acceleration and deceleration time, time unit 0.01s, longest 650.00s, the benchmark optional;
Rated output voltage	Using the compensation function of power supply voltage. When the motor rated voltage range is 100%, it can be set to any value within the range of 50-100% (output voltage can't exceed the input voltage)
Voltage auto-adjustment	When the grid voltage fluctuates, the constant output voltage can be automatically maintained.
Energy-saving running	Depending on the load condition, automatically optimizing the output voltage to save energy.
Current auto-limiting	Auto-limit the current while running to prevent frequent over current break trouble.
Instant power off treatment	When instant power off, control the bus voltage to realize uninterrupted operation.
Standard functions	Superposition of main and auxiliary frequency source, running the command bundle, starting frequency, vector pre-excitation starting, start / stop of DC braking, speed tracking and power-down re-starting, reverse ban and reversing dead time setting, zero speed torque holding, jog operation, frequency hopping, separately set the emergency stop time, FDT detection, timer function, torque control, flux braking and dynamic braking, failure recovery, the last three failure record, process PID controller, multi-velocity and PLC program control, 485 communication interface;
Frequency setting channel	Keyboard digital setting, keyboard potentiometer, analog voltage terminal VS, analog voltage / current terminals AI, analog current terminal AS, given and multi-channel communications terminal selection, main and auxiliary channel combinations
Feedback input channel	Voltage terminal VS1, the voltage / current terminals AI, current terminals AS, communication given, pulse input PUL
Running command channel	Operation panel given, external terminal given, communication given.
Input command signal	Start, stop, FOR/REV, JOG, multi-velocity, free stop, reset, Acceleration/Deceleration time selection, frequency set channel selection, external fault alarm.
External output signal	2 relay outputs, 1-collector output; 0 ~ 10V output, 4 ~ 20mA / 0 ~ 20mA output; Pulse frequency output;

Protection function		Bus overvoltage, mains under voltage, inverter over-current, module failure, inverter overload, motor overload, current detection zero drift failure, Hall failure, E2ROM failure, motor grounding failure, input phase failure, output phase failure, inverter overheating, communication failure, PG card failure, PG disconnection failure, motor parameter self-tuning failure;	
Special Functions	VC mode	2 modes: 1st mode providing high-performance speed effect; 2ed mode providing lower and simple performance testing method;	
	Auto-learning	Asynchronous motors, synchronous motors static parameter learning, rotation parameter learning; Static self-learning induction motors all parameters; PG vector control encoder self-learning;	
	Supporting multiple encoders	Incremental encoder (5V, 12V power supply, frequency dividing output), resolver, SinCos encoders, absolute encoders;	
	VF separation function	Frequency, voltage can be independently given and regulated, supporting multi-channel given way;	
	Terminals, Analog quantity	Providing 4-way virtual X terminals, 4-way virtual Y terminals; supporting delay adjustment of terminal rising and falling; Extending 3-way X terminals by analog quantity; Providing more than two points analog quantity for analog calibration;	
	Motor grounding short circuit detection	Can detect whether the motor is shorted to ground and the electricity can be automatically detected;	
	Servo control	Supporting basic functions like synchronous and asynchronous servo control, pulse tracking, zero servo positioning servo index location, supporting quadrature pulse given;	
	Telecommunication network	supporting 485 / Modbus protocol, CANopen protocol, profibus-DP protocol; Modbus freedom protocol, CAN custom protocols, networking and linkage control between WEICHI inverters can be realized;	
	Remote and monitoring function	Supporting remote upgrading, remote monitoring, remote locking function, can be connected to WEICHI 3G module; Supporting virtual oscilloscope monitoring and debugging;	
Keyboard display	LED display	Single row 4 digital tube display	Can monitor one state variable
		Two row 5 digital tube display	Can monitor two state variables
	Parameter copy	Function code information of frequency inverter can be uploaded and transferred to realize fast parameter copy.	
State monitoring	Output frequency, given frequency, output current, input voltage, output voltage, motor speed, PID feedback, PID given value, module temperature, input and output terminal status		
Environment	Installation site	Indoor, altitude $\leq 1000\text{m}$, no corrosive air or direct sunshine	
	Temperature, humidity	$-10 \sim +40^{\circ}\text{C}$ $20\% \sim 90\%\text{RH}$ (no condensation)	
	Vibration	Under $20\text{Hz} \leq 0.5\text{g}$	
	Storage temperature	$-25 \sim +65^{\circ}\text{C}$	
	Installation method	Hanging type, cabinet type	
	Protection level	IP20	
	Cooling method	Forced air cooling	

1.3 Expansion/SD Card Specification:

There's a variety of optional expansion/SD card for AC100, specified in the table below:

Expansion/SD Card Type	Model	Description
Ordinary photoelectric ABZ encoder PG card	PG01_ABZ_xx_xx	Applicable for ordinary photoelectric encoder: 5V, 12V power output, OC, divided signal output are all optional;
Ordinary photoelectric UVW encoder PG card	PG01_UVW_xx_xx	Applicable for photoelectric encoder with UVW signals or wire-saving type UVW encoder.
Resolver PG card	PG01_RT	Applicable for resolver.
Terminal expansion card	EXIO_01	Applicable for increasing the number of common input terminals, relays, and analog quantity.
Air compressor expansion card	EXIO_02	Applicable for the control of air compressor.
II PG card	PG02_ABZ_xx	Applicable for speed measuring and quadrature pulse given.
DP expansion card	ACDP03	Applicable for expansion of profibus-DP telecommunication
CANopen expansion card	CAN01	Applicable for expansion of CANopen telecommunication
3G telecommunication expansion card	S200-GPS	Applicable for remote monitoring, software upgrades, remote locking
Servo expansion card	EXSV_01	Providing differential input and output terminals and RS232 communication interface.

Chapter 2 Before Use

2.1 Purchase Inspection

On receiving your order, please check the package and confirm intact before opening, and check if there's any damage, scratch or dirt (damages caused during transportation are not within the company's warranty). If there's any damage caused during transportation, please contact us or the transport company immediately.

After confirming the receipt of the goods intact, please re-confirm if the product and your order are consistent. Model of the product is on the "MODEL" column. If you find the product model is not the one you ordered, please contact the dealer you purchased the product or the sales department of VEICHI immediately.

2.2 Nameplate

Nameplate Position and Content

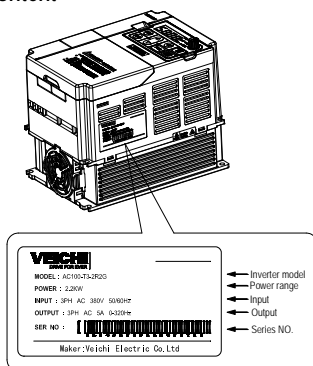

Drawing2-1: AC100 Series Inverter Nameplate Position

Model Specification

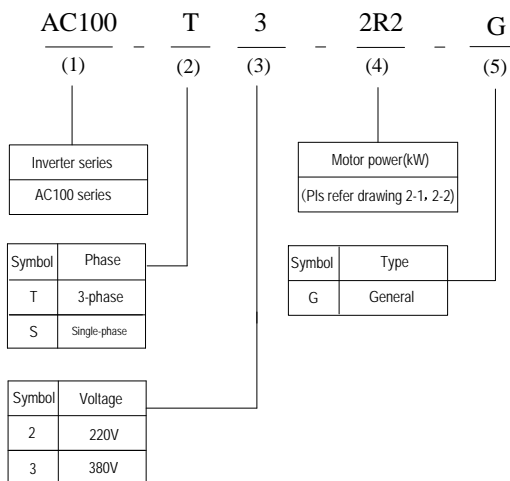

Drawing 2-2: Meaning and Naming Rules of AC100 Series Inverter Nameplate

2.3 Standard Models and Rated Parameters

Single phase 220V

Model	Max adaptive motor	Rated current	Model	Max adaptive motor	Rated current
AC100-S2-R40G	0.4kW	2.5A	AC100-S2-1R5G	1.5kW	7A
AC100-S2-R75G	0.75kW	4A	AC100-S2-2R2G	2.2kW	10A

Table 2-1: AC100 Single Phase 220V Series Inverter Models and Rated Parameters

Three phase 380V

Model	Max adaptive motor	Rated current	Model	Max adaptive motor	Rated current
AC100-T3-R75G	0.75kW	2.5A	AC100-T3-110G	110kW	210A
AC100-T3-1R5G	1.5kW	3.7A	AC100-T3-132G	132kW	250A
AC100-T3-2R2G	2.2kW	5A	AC100-T3-160G	160kW	310A
AC100-T3-004G	4kW	10A	AC100-T3-185G	185kW	340A
AC100-T3-5R5G	5.5kW	13A	AC100-T3-200G	200kW	380A
AC100-T3-7R5G	7.5kW	17A	AC100-T3-220G	220kW	415A
AC100-T3-011G	11kW	25A	AC100-T3-250G	250kW	470A
AC100-T3-015G	15kW	32A	AC100-T3-280G	280kW	510A
AC100-T3-018G	18.5kW	38A	AC100-T3-315G	315kW	600A
AC100-T3-022G	22kW	45A	AC100-T3-355G	355kW	670A
AC100-T3-030G	30kW	60A	AC100-T3-400G	400kW	750A
AC100-T3-037G	37kW	75A	AC100-T3-450G	450kW	800A
AC100-T3-045G	45kW	90A	AC100-T3-500G	500kW	860A
AC100-T3-055G	55kW	110A	AC100-T3-560G	560kW	990A
AC100-T3-075G	75kW	150A	AC100-T3-630G	630kW	1100A
AC100-T3-090G	90kW	180A	AC100-T3-700G	700kW	1260A



Table 2-2: AC100 Three Phase 380V Series Inverter Models and Rated Parameters

Chapter 3 Installation and Wiring

3.1 Safety Precautions

This section specifies the various considerations necessary for reliable and safe operation of the product by users.

Inverter

	<ul style="list-style-type: none"> ● When the inverter is installed in closed cabinet, please ensure the temperature at the air-in port below 40°C by way of cooling fans or air conditioners and other cooling equipment to ensure the safe and reliable operation of the inverter.
	<ul style="list-style-type: none"> ● When installing, please cover the inverter with cloth or paper to prevent metal dust, oil, water and others. And remove these cover carefully after working. ● Please follow the ESD regulations when operating the inverter, otherwise, the inverter may be damaged. ● If several inverters are installed in a cabinet, enough space must be set aside on the upper part of the inverter in order to change the cooling fan. ● Inverter can't work over rated range. Otherwise, the inverter may be damaged. ● When transporting the inverter, please hold the case firmly. There might be danger of inverter main body falling, personnel injury or inverter damage if only holding the pre-cover.

Motor

	<ul style="list-style-type: none"> ● Different motor has different max allowable running speed. Motor can't run over the max allowable running speed. ● When inverter is running at low speed, the motor auto-cooling effect would seriously decrease. If motor runs at low speed for long term, it will be damaged for overheating. If needed, please use special motor for inverter. ● When constant speed machinery runs at inconstant speed, there might be sympathetic vibration. Please install vibration-proof rubber under motor rack or use jumping frequency control function. ● When using frequency inverter or working frequency power supply to drive, the torque characteristics are different. Please do confirm the torque characteristic of the equipment connected. ● The rated current of shift gear motor is different from that of standard motor. Please confirm and choose the right frequency inverter. Moreover, please do switch the pole when the inverter input current is 0. Otherwise, it may bring inverter damage. ● The rated current of diving motor is higher than that of standard motor, please confirm and choose the right inverter. ● When the wiring distance between motor and inverter is far, the max torque of the motor would reduce due to voltage drop. So please use cable thick enough when the distance between the motor and the inverter is long.
--	--

3.2 Dealing Methods for Inverter after Long-term Storage

If the inverter storage time is over one year, the aluminum capacitor in the inverter must be pre-charged again and make sure the aluminum capacitor characteristic recovered before installation. For specific method, please follow the grads in the chart below and give more than 30 mins corresponding proportional voltage for every grad when the inverter is no-load.

If the input voltage of one grad is at the critical point of contactor, fan or other equipments, please increase or reduce the corresponding input voltage for the grad to avoid any related components working under critical state.

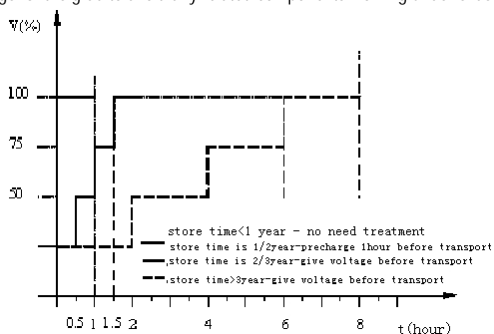

Chart 3-1: Dealing Methods for Inverter after Long-term Storage

3.3 Stable Running Environment for Inverter

Installation environment is very important to maximize the performance of this product and maintain long-term function, so please install the product in the environment as required in the following chart.

Environment	Requirement
Installation site	Indoor without direct sunshine
Operating temperature	-10 ~ +40°C (hanging type) -10 ~ +45°C (cabinet type)
Storage temperature	-20 ~ +60°C
Environment humidity	<95%RH, no condensation
Surroundings	Please install the inverter in place as follows: <ul style="list-style-type: none"> ● Place without oil mist, corrosive gases, flammable gas, dust, etc. ● Place where metal dust, oil, water would not get inside the inverter (please do not install inverter on flammable material such as wood, etc). ● Place without radioactive material or flammable material. ● Place without poisonous gases or liquid. ● Place with little salt corrosion. ● Place without direct sunshine.
Altitude	<1000m
Vibration	<10~20Hz:9.8m/s ² <20~55Hz:5.9m/s ²
Installation and cooling	<ul style="list-style-type: none"> ● Inverter must be installed vertically and longitudinally, and it can't be installed horizontally. ● Please independently install high heating equipments such as braking resistor and it can't be installed in the same cabinet with inverter. Installation of high heating equipments at the air-in port of the inverter is strictly prohibited.

Chart 3-1:AC100 Series Inverter Running Environment Condition

- To improve product reliability, please use the inverter where temperature would not change suddenly; when using in a closed cabinet, cooling fan or air conditioning for cooling is needed to prevent the internal temperature from exceeding allowed temperature; please avoid freezing of the inverter since low temperatures may cause malfunction of some devices due to freezing.
- Derate according to the chart when temperature exceeds limit.

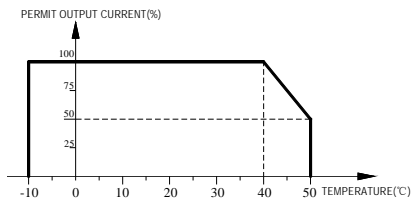

Chart 3-2: AC100 Series Inverter Derating Curve When Exceeding Permitted Temperature

- Derate according to the chart when altitude exceeds limit.

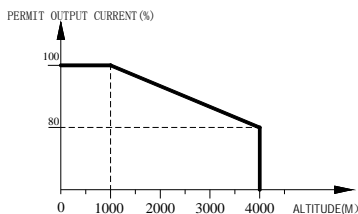

Chart 3-3: AC100 Series Inverter Derating Curve When Exceeding Permitted Altitude

3.4 EMI Protection



The designing features of inverter allow it to run with strong electromagnetic interference. Generally, if the quality of the installation is good, the safe and trouble-free operation of the inverter can be guaranteed. Please implement installation according to the following rules to ensure reliable and effective installation of inverters and avoiding electromagnetic interference.

- Make sure that all equipments in the cabinet have been connected reliably to the public Y-type earth point or earth bus with thick and short cable. The motor earth should be as close as possible. Please do not connect the motor shell to earth terminal of the inverter or the protective area of control system.
- Make sure that all devices connected to the inverter are connected to the same earth net or Y-type earth point with thick and short cable.
- It would be better for conductors to be flat and multi-core since they have lower impedance at high frequencies.
- When cutting off the tip, the cable should be as neat as possible to make sure that the unscreened wires are as short as possible.
- Wiring of control cable should be away from the power supply cable and motor cable as far as possible; separate trunk should be used and a 90° vertical cross must be used when the supply power cable and the motor cable intersect.
- Make sure that the contactor should be installed in a cabinet with a surge suppressor. Alternatively, the AC contactor coil is connected with 'R-C' damping circuit, using a coil voltage corresponding varistor; the DC contactor coil is connected with 'flywheel' diodes or pressure thermistor type devices corresponding to the coil voltage, which is particularly important when the contactor frequently operates and when contactor is controlled by the output relay of the inverter.
- Cable connected to motor should be shielded cable or armored cable. The two barriers are earthed reliably by cable

earthing card.

- Installation 'Input Noise Filter' can reduce electromagnetic interference from other devices of the grid side, 'Input Noise Filter' must be as close to the inverter input terminals, at the same time, the filter must earth reliably as the inverter.
- Installation 'output side noise filter' can reduce interference from radio interference and induction noise. 'Output side noise filter' must be as close to the inverter output terminals, at the same time, the filter must earth reliably as the inverter.
- Control circuit cable should be shielded cables all the time;
- Adding zero phase reactor in power supply wire near inverter input terminal, adding zero phase reactor in the motor wire near inverter output terminal and adding zero phase reactor in control wire near inverter control terminal to efficiently reduce electromagnetic interference to the inverter.
- Earth

Right and reliable earth is the basic condition of safe and reliable running of the product. For right earth, please read the following notice carefully.

	<ul style="list-style-type: none"> ● To avoid electric shock, earth cable should be the size as specified in the technical standards for electrical equipment. And cable length should be as short as possible. Otherwise, leakage current of inverter would cause unstable potential of the earth terminal which is far from the earth point, and electric shock accident would happen frequently. ● Be sure to ground the ground terminal. Grounding resistance 10Ω or less, it may cause injury or death ● Earth terminal must be earth. Earth resistance must be below 10Ω. Otherwise, there is danger of injury and death.
	<ul style="list-style-type: none"> ● Please do not share earth cable with welder or other big current/pulse power equipment. Otherwise, inverter would act abnormally. ● When multi inverters are used at the same time, please do not wind the earth wire to loop-type. Otherwise, inverter will act abnormally.

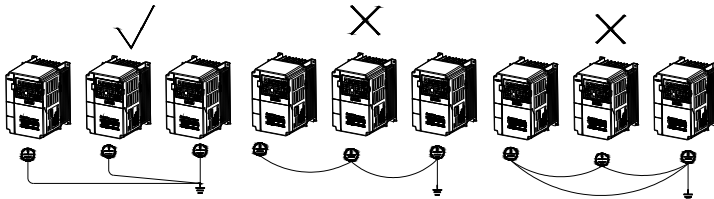

Chart 3-4: Multi AC100 Series Inverters United Earth

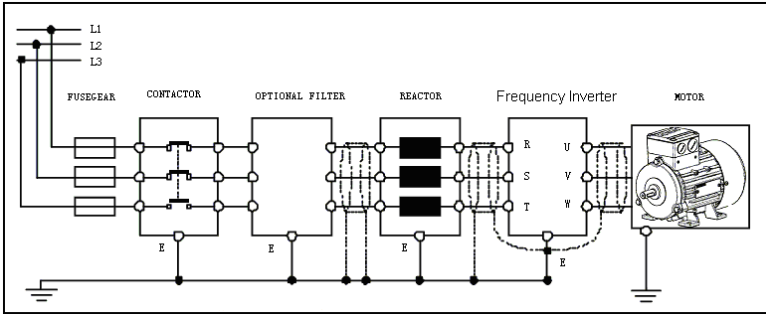

Chart 3-5: AC100 Series Inverter System Earth

Note: motor must earth as close as possible. Motor shell can't be connected to the inner earth terminal of the inverter and it can't share the earth net with the control system either.

- Power cable, motor cable, control cable of inverter

Shielding layer (reticulate/armored) should be wound reliably by cable earth card and then fixed to inverter earth piece by bolt. Please refer to the following chart.

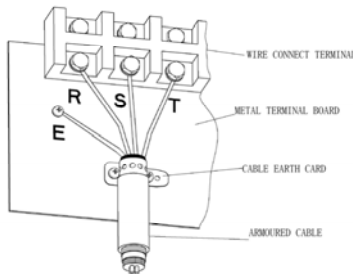

Chart 3-6: Cable Earth Card for Cable Earth

- Correspondence between inverter and motor cable length and carrier frequency

When wiring distance between inverter and motor is long (especially low-frequency output), cable voltage drop will cause the motor torque reduction. Moreover, high-frequency leakage current will increase, thereby causing an increase of inverter output current, which would cause the inverter over current trip. And the current detection accuracy and running stability would be seriously affected. Please refer to the cable length in the following table to adjust the carrier frequency. When system requires the wiring distance to be more than 100m, please adopt distributed capacity reduce measure (Such as "no metal conductor covers cable", "wire each phase cable apart" and so on)

Cable length	<20m	20-50m	50-100m	>100m
Carrier frequency	0.6-16kHz	0.6-8kHz	0.6-4kHz	0.6-2kHz

Chart 3-2: Correspondence between Inverter and Motor Cable Length and Carrier Frequency

3.5 Machinery Installation

Installation Notice and Related Requirement

- AC100 inverter components



Chart 3-7: AC100 Series Inverter Components

- Installation Direction

To prevent reduction of inverter cooling effect, please do install the inverter longitudinally-mounted.

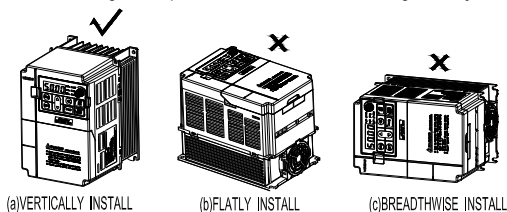

Chart 3-8: AC100 Series Inverter Installation Direction

- Installation Space

Single machine installation: to ensure enough ventilation and wiring space for inverter cooling, please follow installation conditions as follows. The back of the inverter should stick to the wall so that the surrounding air of radiator can flow freely to ensure the cooling effect.

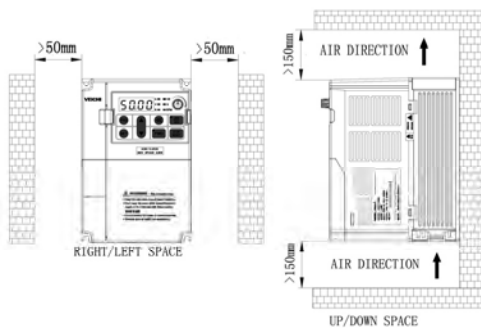

Chart 3-9: Single AC100 Series Inverter Installation Space

Multi inverters paratactic installation: when installing multi inverters in cabinet, please ensure installation space as required below.

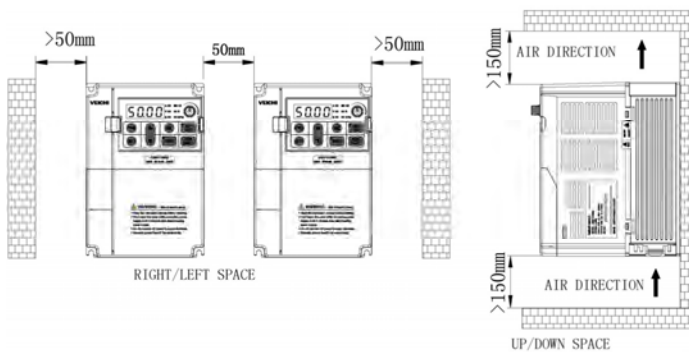
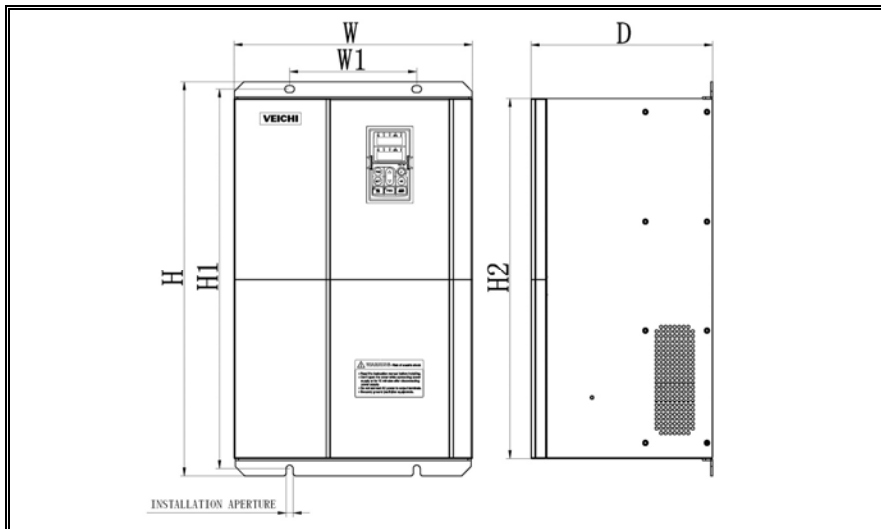

Chart 3-10: Multi AC100 Series Inverters Paratactic Installation Space Requirement

Overall Dimension of Inverter and Keyboard

MODEL	W	W1	H	H1	D	D1	INSTALLATION APERTURE
AC100-S2-R40G	122	112	182	171	154.5	145	φ5
AC100-S2-R75G							
AC100-S2-1R5G							
AC100-S2-2R2G	159	147.2	246	236	157.5	148	φ5.5
AC100-T3-R75G	122	112	182	171	154.5	145	φ5
AC100-T3-1R5G							
AC100-T3-2R2G							
AC100-T3-004G	159	147.2	246	236	157.5	148	φ5.5
AC100-T3-5R5G							
AC100-T3-7R5G	195	179	291	275	167.5	158	φ7
AC100-T3-011G							
AC70-T3-015G/018P (plastic cover machine)	230	208	330	315	200	190	φ7

AC70-T3-018G/022P (plastic cover machine)	230	208	330	315	200	190	φ7
AC70-T3-022G/030P (plastic cover machine)							



MODEL	Overall Dimension				Instillation Position		INSTALLATION APERTURE
	W	H	D	H2	W1	H1	
AC100-T3-015G (steel cover machine)	235	345	200	311	160	331.5	φ7
AC100-T3-018G (steel cover machine)							
AC100-T3-022G (steel cover machine)	255	410	225	370	180	395	φ7
AC100-T3-030G							
AC100-T3-037G	305	570	260	522	180	550	φ9
AC100-T3-045G							
AC100-T3-055G							
AC100-T3-075G	380	620	290	564	240	595	φ11
AC100-T3-090G							
AC100-T3-110G							

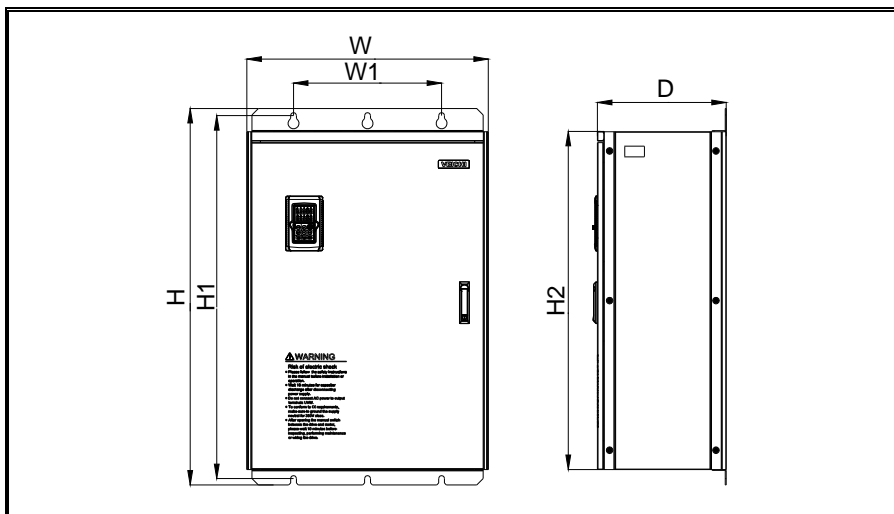

MODEL	Overall Dimension				Instillation Position		INSTALLATION APERTURE
	W	H	D	H2	W1	H1	
AC100-T3-132G	500	780	340	708	350	755	φ11
AC100-T3-160G	650	1060	400	950	400	1023	φ16
AC100-T3-185G							
AC100-T3-200G							
AC100-T3-220G	750	1170	400	1050	460	1128	φ18
AC100-T3-250G							
AC100-T3-280G							
AC100-T3-315G	850	1280	450	1150	550	1236	φ20
AC100-T3-355G							
AC100-T3-400G							

Notice: No DC Reactor Inside

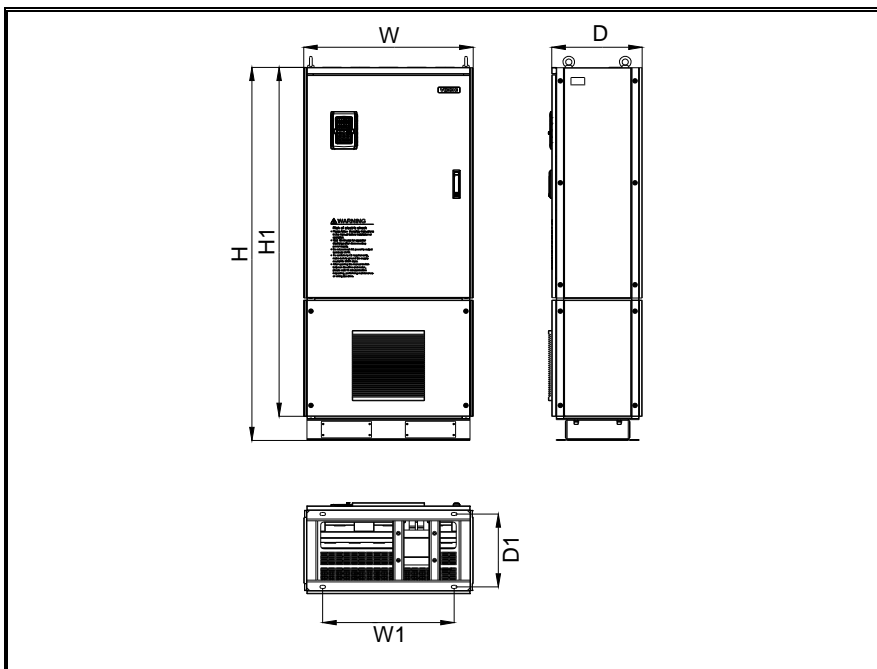

MODEL	Overall Dimension				Instillation Position		INSTALLATION APERTURE
	W	H	D	H1	W1	D1	
AC100-T3-160GD	650	1600	400	1500	492	332	φ14
AC100-T3-185GD							
AC100-T3-200GD							
AC100-T3-220GD	750	1700	400	1600	582	332	φ14
AC100-T3-250GD							
AC100-T3-280GD							
AC100-T3-315GD	850	1800	450	1700	622	382	φ14
AC100-T3-355GD							
AC100-T3-400GD							

Notice: DC Reactor Inside

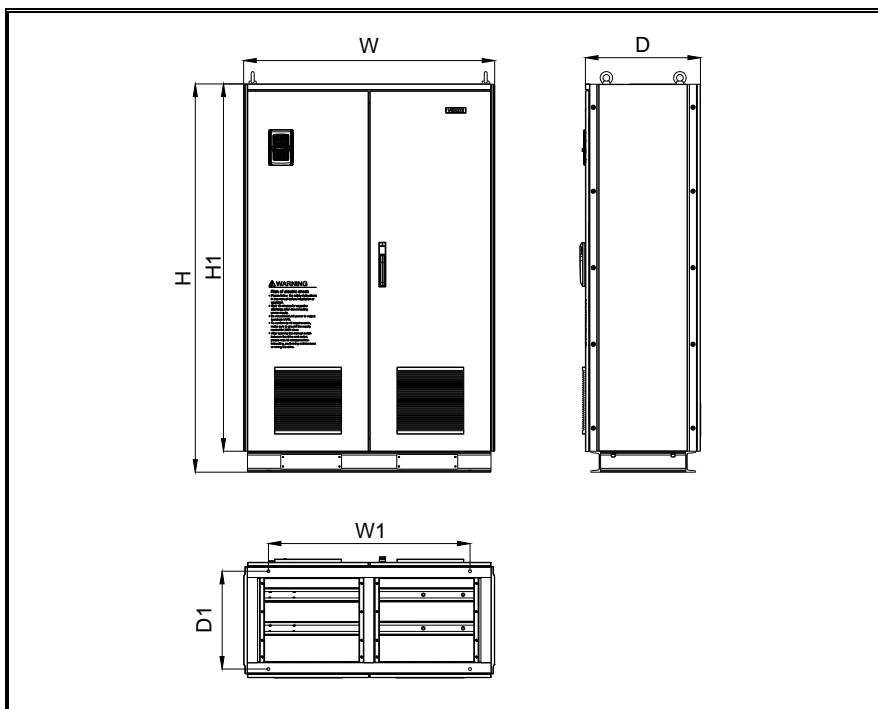

MODEL	Overall Dimension				Instillation Position		INSTALLATIO N APERTURE
	W	H	D	H1	W1	D1	
AC100-T3-450G	1200	1850	550	1750	960	466	φ14
AC100-T3-500G							
AC100-T3-560G							

Chart 3-3: AC100 Series Inverter Overall Dimension

Keyboard Shape and Mouth Dimension

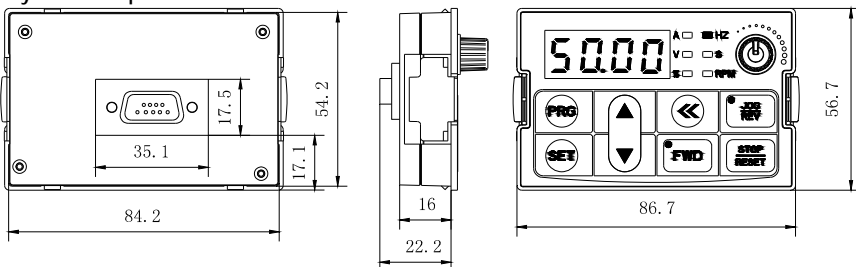

Chart 3-11:AC100 Series Inverter Single Line LED Keyboard Overall Dimension

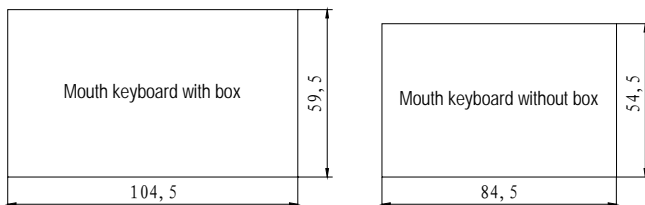

Chart 3-12:AC100 Series Inverter Mouth Dimension for Single Line LED Keyboard Case

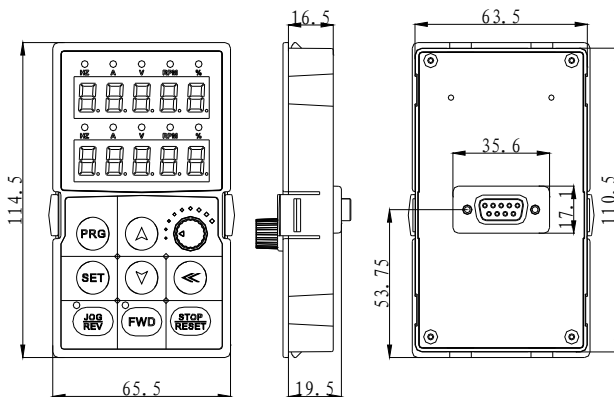

Chart 3-13: AC100 Series Inverter Double Line LED Keyboard Overall Dimension

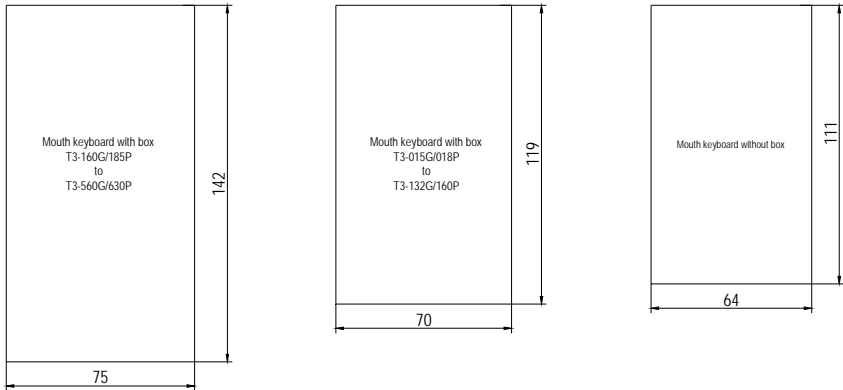

Chart 3-14: AC100 Series Inverter Mouth Dimension for Double Line LED Keyboard Case

Note: LCD and LED keyboard overall dimensions and the opening dimensions are fully compatible.

Installation and Dismantlement of Tail-hood

Installation: First the tail-hood upwardly inclines around 15 degree and then inserts the top fixed flat into the fixed hole in the front cover. Then slightly press the tail-hood downward. When you hear "Ka", it means that the tail-hood is installed in place.

Chart 3-15: AC100 Series Inverter Tail-hood Installation

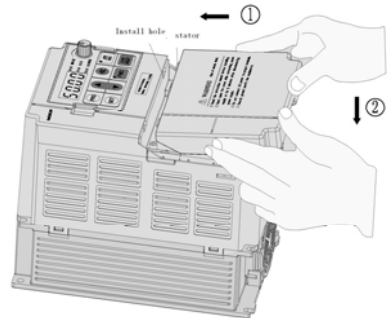

Dismantlement: At the tail of the frequency inverter, there's a special dismantlement hole design. Put your finger through the hole, upwardly pull the cover slightly until the buckle between the tail-hood and the crust tear off, and then remove the tail-hood.

Chart 3-16: AC100 Series Inverter Tail-hood Dismantlement

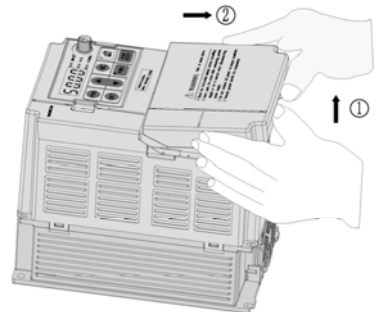

Installation and Dismantlement of keyboard

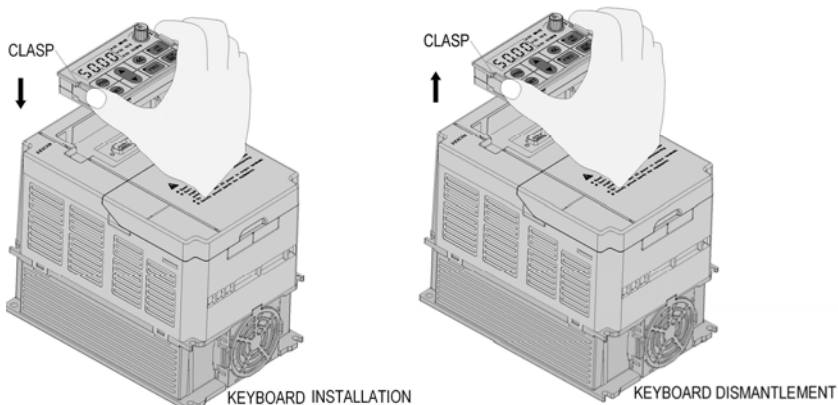

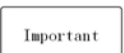

Chart 3-17: AC100 Series Inverter Keyboard Installation and Dismantlement

3.6 Electrical Installation

To ensure safe, reliable and rational use of this product, please fully understand the safety precautions described in this manual before using.

Safety Precautions

	<ul style="list-style-type: none"> ● Inverter must earth reliably when running. Otherwise there is danger of casualty and unstable inverter performance. ● To ensure safety running, only trained personnel can do installation and wiring job. ● No operation under power connected state. Otherwise there might be danger of electric shock even death. ● Please turn off the power of all related equipment, and make sure the main circuit DC voltage has dropped to a safe level, and wait five minutes before any relevant job.
	<ul style="list-style-type: none"> ● The wiring of control cables, power cables and motor connection cables must be isolated from each other and do not put them in the same cable though or cable racks. ● The device can only be used as specified by the manufacturer, Please consult Veichi when using in special case.
	<ul style="list-style-type: none"> ● No insulation tests for the inverter or the related cable by HV insulation test equipment. ● If the inverter or the peripheral equipment (filer, reactor and etc) needs insulation test, firstly 500V meter should be used to test the insulation resistance, which should not be lower than 4MΩ.

Standard Connection Diagram

● Standard Connection Diagram

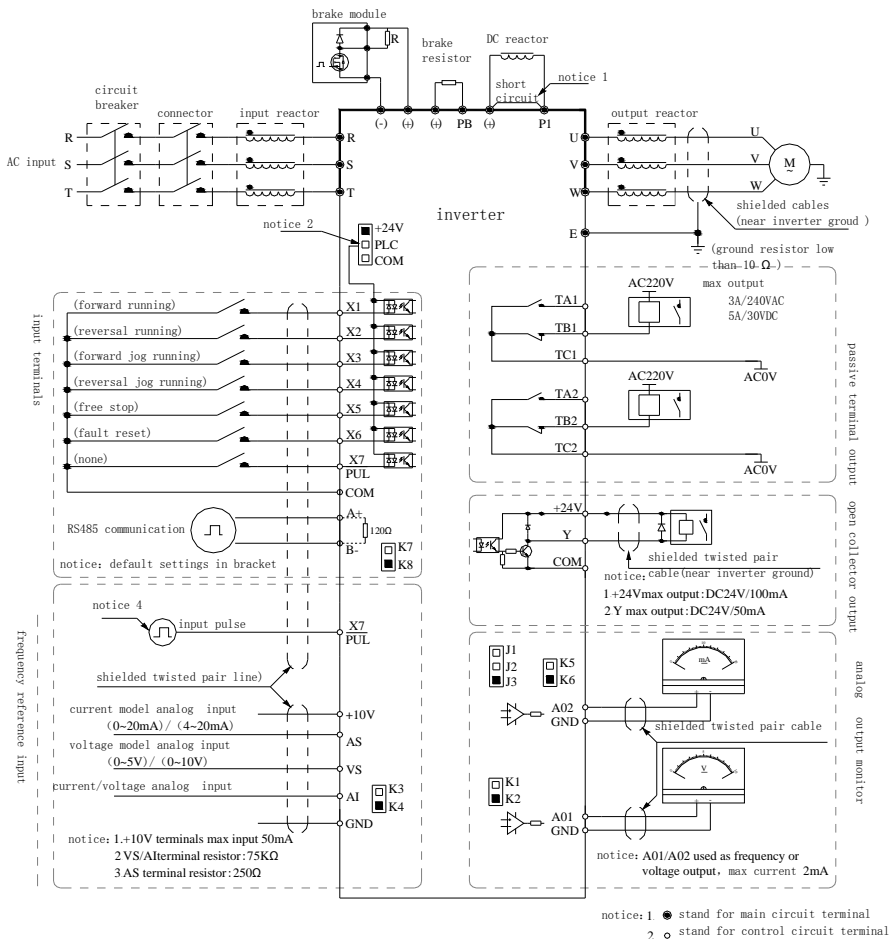

Chart 3-18: AC100 Series Inverter Standard Connection Diagram

- When installing DC reactor, make sure to dismantle the short connector between terminal P1 and (+).
- NPN or PNP transistor signal can be selected as input of multi-function input terminal (X1-X7/PUL). Inverter built-in power supply (+24V terminal) or external power supply (PLC terminal) can be chosen as bias voltage. Factory setting '+24V' short connect with 'PLC'.
- Analog monitor output is the special output for meters such as frequency meter, current meter and voltage meter. It can't be used for control operations such as feedback control.
- As there are multi pulse styles, please refer to the line connect mode description details.

● Auxiliary Terminal Output Capacity

Terminal	Function Definition	Max Output
+10V	10V auxiliary power supply output, constitutes loop with GND.	50mA
A01/A02	Analog monitor output, constitutes loop with GND.	Max output 2mA as frequency, voltage signal,
+24V	24V auxiliary power supply output, constitutes loop with COM.	100mA
Y	Collector open circuit output; can set the action-object by program.	DC24V/50mA
TA1/TB1/TC1 TA2/TB2/TC2	Passive connector output; can set the action-object by program.	3A/240VAC 5A/30VDC

Chart 3-4: AC100 Series Inverter Auxiliary Terminals Output Capacity

● Connection Function Specification of Switch Terminals

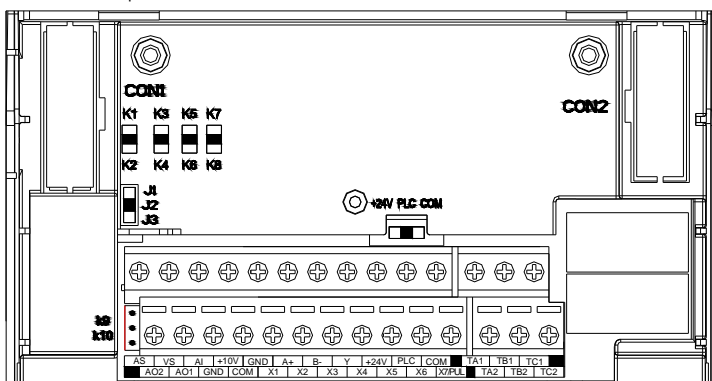

Switch Terminal	Selecting Position	Function Specification
S1	K1	A01: 0~20mA or 4~20mA current output
	K2	A01: 0~10V voltage output
S2	K3	AI: 0~20mA or 4~20mA input current
	K4	AI: 0~10V input voltage
S3	K5	A02: 0.0~50kHz (J1 on), open collector circuit output
	K6	A02: 0.0~50kHz (J1 on), active source output
S4	K7	RS485: connect with 120Ω terminal resistor
	K8	RS485: connect without 120Ω terminal resistor
S5	J1	A02: 0.0~50kHz frequency output
	J2	A02: 0~20mA or 4~20mA current output
	J3	A02: 0~10V voltage output

S6	+24V	Short +24V terminal and PLC terminal
	PLC	PLC terminal receiving external power input, detailed in Drawing 3-22, 3-23
	COM	Short PLC terminal and COM terminal
S7	K9	Disconnect GND terminal and PE discharge loop
	K10	Connect GND terminal and PE discharge loop

Chart 3-5: AC100 Series Inverter Switch Terminal Connection Function Specification

Main Circuit Terminals

- Main circuit terminals array and definition

Arrangement sequence of main circuit terminal with 18.5kW or less power(15 ~ 18.5kW for steel cover machine)



Arrangement sequence of main circuit terminal with 15-22kW(15-22kW for plastic cover machine)

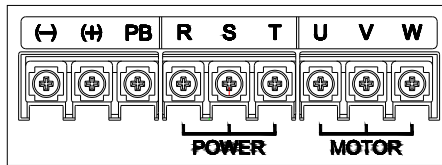

Arrangement sequence of main circuit terminal with 22-30kW (standard machine without PB terminal) (22kW for steel cover machine)

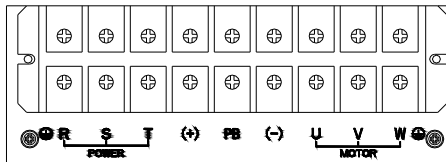

Arrangement sequence of main circuit terminal with 37-110kW

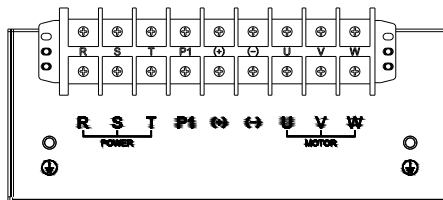

Terminal Symbol	Name	Function Definition
(-)	DC power terminal	DC power output, (-) means DC bus cathode, (+) means DC bus anode, used for external braking unit.
(+)		
PB	Braking resistance terminal	Used for external braking resistance to realize quick stop.
P1	DC reactor terminal	Used for external DC reactor.
(+)		
R	Inverter input terminal	Used to connect 3-phase AC power supply.
S		
T		
U	Inverter output terminal	Used to connect the motor.
V		
W		
\oplus	Earth	Earth terminal, earth resistance<10Ω
E		

Chart 3-6:AC100 Series Inverter Main Circuit Terminals Array and Definition

● 3-phase 380V Machine Main Circuit Wiring

Model	Main Circuit Terminals Screw Specifications	Suggested Fixed Moment (N·m)	Suggested Copper-core Cable Specification mm ² (AWG)
AC100-T3-R75G	M4	1.2~1.5	1.5mm ² (14)
AC100-T3-1R5G	M4	1.2~1.5	2.5mm ² (12)
AC100-T3-2R2G	M4	1.2~1.5	2.5mm ² (12)
AC100-T3-004G	M4	1.2~1.5	4mm ² (10)
AC100-T3-5R5G	M4	1.2~1.5	6mm ² (9)
AC100-T3-7R5G	M5	2~2.5	6mm ² (9)
AC100-T3-011G	M5	2~2.5	10mm ² (7)
AC100-T3-015G	M6	4~6	10mm ² (7)
AC100-T3-018G	M6	4~6	16mm ² (5)
AC100-T3-022G	M8	8~10	16mm ² (5)
AC100-T3-030G	M8	8~10	25mm ² (3)
AC100-T3-037G	M8	8~10	25mm ² (3)
AC100-T3-045G	M8	8~10	35mm ² (2)

AC100-T3-055G	M10	11~13	35mm ² (2)
AC100-T3-075G	M10	11~13	50mm ² (1)
AC100-T3-090G	M10	11~13	50mm ² (1/0)
AC100-T3-110G	M10	11~13	70mm ² (2/0)
AC100-T3-132G	M10	11~13	95mm ² (3/0)
AC100-T3-160G	M12	14~16	95mm ² (4/0)
AC100-T3-185G	M12	14~16	120mm ²
AC100-T3-200G	M12	14~16	150mm ²
AC100-T3-220G	M12	14~16	150mm ²
AC100-T3-250G	M12	14~16	185mm ²
AC100-T3-280G	M12	14~16	185mm ²
AC100-T3-315G	M16	20~23	240mm ²
AC100-T3-355G	M16	20~23	240mm ²
AC100-T3-400G	M16	20~23	300mm ²
AC100-T3-450G	M16	20~23	400mm ²
AC100-T3-500G	M16	20~23	400mm ²
AC100-T3-560G	M16	20~23	500mm ²

Note: Here we suggest using copper joins for mains electric connectors for machine over 185KW. Please refer to diagram above for the cut section area.

Chart 3-7: Suggested Cable Diameter and Fixed Moment of 3-phase 380V Machine Main Circuit

● Single-phase 220V Machine Main Circuit Wiring

Model	Main Circuit Terminals Screw Specifications	Suggested Fixed Moment (N·m)	Suggested Copper-core Cable Specification mm ² (AWG)
AC100-S2-R40G	M4	1.2~1.5	1.5mm ² (14)
AC100-S2-R75G	M4	1.2~1.5	2.5mm ² (12)
AC100-S2-1R5G	M4	1.2~1.5	2.5mm ² (12)
AC100-S2-2R2G	M4	1.2~1.5	4mm ² (10)

Chart 3-8: Suggested Cable Diameter and Fixed Moment Single-phase 220V Machine Main Circuit

● Suggested Main Circuit Components Specification

Model	Contactors Specification	Breaker Specification	DC Reactor	Input Filter	Output Filter
AC100-T3-R75G	10A	10A	-----	NFI-005	NFO-010
AC100-T3-1R5G	10A	10A	-----	NFI-005	NFO-010
AC100-T3-2R2G	16A	15A	-----	NFI-010	NFO-010
AC100-T3-004G	16A	20A	-----	NFI-010	NFO-010
AC100-T3-5R5G	25A	20A	-----	NFI-020	NFO-020
AC100-T3-7R5G	25A	30A	-----	NFI-020	NFO-020
AC100-T3-011G	32A	40A	-----	NFI-036	NFO-036
AC100-T3-015G	40A	50A	-----	NFI-036	NFO-036

AC100-T3-018G	50A	60A	-----	NFI-050	NFO-050
AC100-T3-022G	50A	75A	DCL-50	NFI-050	NFO-050
AC100-T3-030G	63A	100A	DCL-80	NFI-080	NFO-080
AC100-T3-037G	80A	125A	DCL-100	NFI-100	NFO-100
AC100-T3-045G	100A	150A	DCL-110	NFI-100	NFO-100
AC100-T3-055G	125A	175A	DCL-125	NFI-150	NFO-150
AC100-T3-075G	160A	200A	DCL-150	NFI-150	NFO-150
AC100-T3-090G	220A	250A	DCL-200	NFI-200	NFO-300
AC100-T3-110G	220A	300A	DCL-200	NFI-200	NFO-300
AC100-T3-132G	250A	400A	DCL-300	NFI-300	NFO-300
AC100-T3-160G	300A	500A	DCL-300	NFI-300	NFO-300
AC100-T3-185G	400A	600A	DCL-400	NFI-400	NFO-400
AC100-T3-200G	400A	700A	DCL-400	NFI-400	NFO-400
AC100-T3-220G	630A	800A	DCL-500	NFI-600	NFO-600
AC100-T3-250G	630A	1000A	DCL-600	NFI-600	NFO-600
AC100-T3-280G	630A	1200A	DCL-600	NFI-600	NFO-600
AC100-T3-315G	630A	1200A	DCL-800	-----	-----
AC100-T3-355G	800A	1400A	DCL-800	-----	-----
AC100-T3-400G	1000A	1600A	DCL-1000	-----	-----
AC100-T3-450G	1000A	2000A	DCL-1000	-----	-----
AC100-T3-500G	1000A	2000A	DCL-1200	-----	-----
AC100-T3-560G	-----	2000A	DCL-1200	-----	-----

Note: For specification details and circuit mode of DC reactor, input filter, output filter and other components, please refer to Chapter 7 "Peripheral Equipments and Options".

Chart 3-9: Suggested Mains Fittings for 3-phase 380V Machine

Control Loop Terminals

- Control Loop Terminals Array:

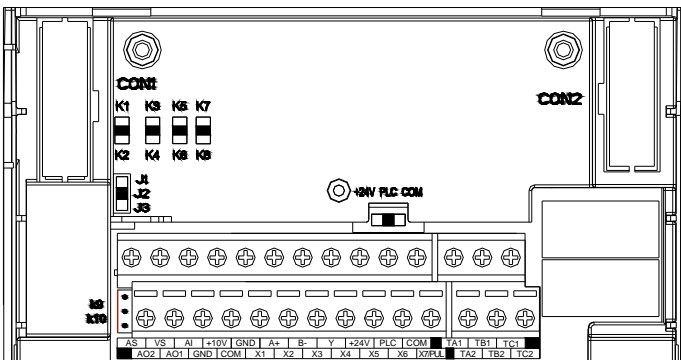

Category	Terminal Symbol	Name	Function Definition
Power	+10V-GND	+10V power supply	Supply +10V power, max output current: 50 mA ,usually used for potentiometer supply, resistance of potentiometer range: 1K Ω ~ 5K Ω
	+24V-COM	+24V power supply	Supply +24V power, usually used for digital input/output terminals and external sensors, max output current:100 mA
	PLC	Public terminal	Connect with +24V terminal by factory default. When using external signal to drive X1-X7/PUL,PLC must be connected with external power, and be disconnected with +24V terminal (detailed in Drawing 3-22, 3-23)
Analog input	AS-GND	Current analog input	1.input current range: DC 0mA~20mA 2.input impedance: 500 Ω
	VS-GND	Voltage analog input	1.input voltage range: DC 0V~10V 2.input impedance: 75 K Ω
	AI-GND	Voltage or current analog input	1.input range: DC 0V~10V/0mA~20mA, decided by switch S2(detailed in Drawing 3-5) 2.voltage input impedance: 75 K Ω 3.current input impedance: 500 Ω

Chart 3-10: AC100 Series Inverter Control Loop Terminals Array and Definition

- Control Loop Terminal Wiring Specification

Terminal	Bolt Specification (mm)	Fixed Moment (N·m)	Cable specification (mm ²)	Cable Type
A+ B-	M2.5	0.4~0.6	0.75	Twisted-pair shielded cable
+10V GND A01 A02 AS VSAI	M2.5	0.4~0.6	0.75	Twisted-pair shielded cable
+24V COM Y TA1 TB1 TC1 TA2 TB2 TC2 PLC X1 X2 X3 X4 X5 X6 X7/PUL	M2.5	0.4~0.6	0.75	Shielded cable

Chart 3-11: Control Loop Terminal Wiring Specification

Braking Unit (Braking Resistance) Connection

- Brake resistance wiring of machine with 18.5KW or less power (15KW-18.5KW for steel cover machine)

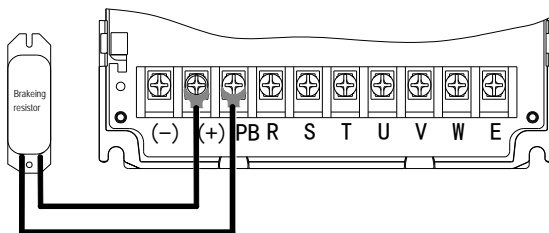

Fig 3-19: AC100 Series Frequency Inverter Brake resistance wiring of machine with 18.5KW or less power

- Brake resistance wiring of machine with 15-22KW (for plastic cover machine)

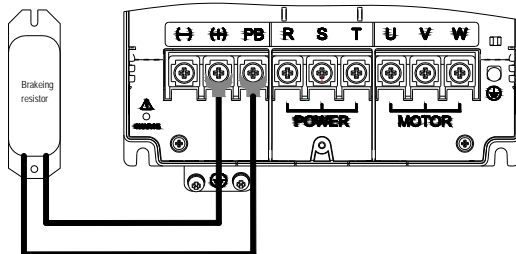

Fig 3-20: AC100 Series Frequency Inverter Brake resistance wiring of machine with 15-22KW (for plastic cover machine)

- Brake resistance wiring of machine with 22KW and 30KW(built-in brake is optional) (22KW for steel cover machine)

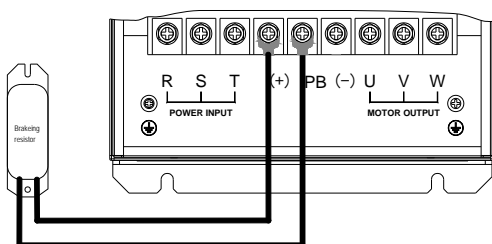

Fig 3-21: AC100 Series Frequency Inverter Brake resistance wiring of machine with 22KW and 30KW(built-in brake is optional) (22KW for steel cover machine)

- Brake resistance wiring of machine with 37KW or above

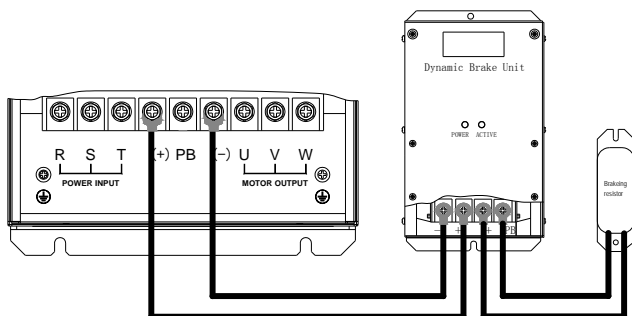

Fig 3-22: AC100 Series Frequency Inverter Brake resistance wiring of machine with 37KW or above

- Suggested braking resistance specification parameters

The braking resistance value and resistance power in the chart below are in accordance with the general inertia of the load and intermittent braking mode, In large inertia and long braking frequent occasions, adjust resistance value and power according to the inverter specification and the rated parameter of braking unit. If any problem, please consult customer service department of Shenzhen Veichi Electric Co., Ltd.

Three-phase 380V			
Motor power(kW)	Resistance value(Ω)	Resistance Power(kW)	Braking Moment (%)
0.75 kW	750 Ω	150W	100%
1.5 kW	400 Ω	300W	100%
2.2 kW	250 Ω	400W	100%
4.0 kW	150 Ω	500W	100%
5.5 kW	100 Ω	600W	100%
7.5 kW	75 Ω	780W	100%
11 kW	50 Ω	1,200W	100%
15 kW	40 Ω	1,500W	100%
18.5 kW	32 Ω	2,000W	100%
22 kW	28 Ω	2,200W	100%
30 kW	24 Ω	3,000W	100%
37 kW	20 Ω	3,700W	100%
45 kW	16 Ω	4,500W	100%
55 kW	13 Ω	5,500W	100%
75 kW	9 Ω	7,500W	100%
90 kW	6.8 Ω	9,300W	100%
110 kW	6.2 Ω	11,000W	100%
132 kW	4.7 Ω	13,000W	100%
160 kW	3.9 Ω	15,000W	100%
185 kW	3.3 Ω	17,000W	100%
200 kW	3 Ω	18,500W	100%
220 kW	2.7 Ω	20,000W	100%
250 kW	2.4 Ω	22,500W	100%
280 kW	2 Ω	25,500W	100%
315 kW	1.8 Ω	30,000W	100%
355 kW	1.5 Ω	33,000W	100%
400 kW	1.2 Ω	42,000W	100%
450 kW	1.2 Ω	42,000W	100%
500 kW	1 Ω	42,000W	100%
560 kW	1 Ω	50,000W	100%
Single-phase 220V			
Motor power(kW)	Resistance value(Ω)	Resistance power(kW)	Braking moment (%)
0.4 kW	400 Ω	100W	100%

0.75 kW	200Ω	120W	100%
1.5 kW	100Ω	300W	100%
2.2 kW	75Ω	300W	100%

Chart 3-12: Suggested Braking Resistance Specification Parameters of AC100 Series Inverter

● Build-in braking unit max braking performance

Braking unit of AC100 series product with low power can be selected according to the suggested braking resistance specification parameters in chart 3-11. In large inertia or long time frequent braking occasion, the moment should be increased. The max braking power is stated in the following chart and the range of which can't be exceeded in use. Otherwise the equipment may be damaged. If any problem, please consult customer service department of Shenzhen Veichi Electric Co., Ltd.

Three-phase 380V			
Inverter Model	Motor Power	Max Braking Current	Min Resistance
AC100-T3-R75G	0.75 kW	3.5A	200 Ω
AC100-T3-1R5G	1.5 kW	3.5A	200 Ω
AC100-T3-2R2G	2.2 kW	7A	100 Ω
AC100-T3-004G	4 kW	10A	75 Ω
AC100-T3-5R5G	5.5 kW	10A	75 Ω
AC100-T3-7R5G	7.5 kW	14A	50 Ω
AC100-T3-011G	11 kW	17A	40 Ω
AC100-T3-015G	15 kW	23A	30 Ω
AC100-T3-018G	18.5 kW	28A	25 Ω
Single-phase 220V			
Inverter Model	Motor Power	Max Braking Current	Min Resistance
AC100-S2-R40G	0.4 kW	3.8A	100 Ω
AC100-S2-R75G	0.75 kW	3.8A	100 Ω
AC100-S2-1R5G	1.5 kW	6.5A	60 Ω
AC100-S2-2R2G	2.2 kW	10.5A	40 Ω

Chart 3-13: AC100 Series Inverter Build-in Braking Unit Max Braking Power

Multi-functional Contact Input Connection

- NPN transistor connection mode

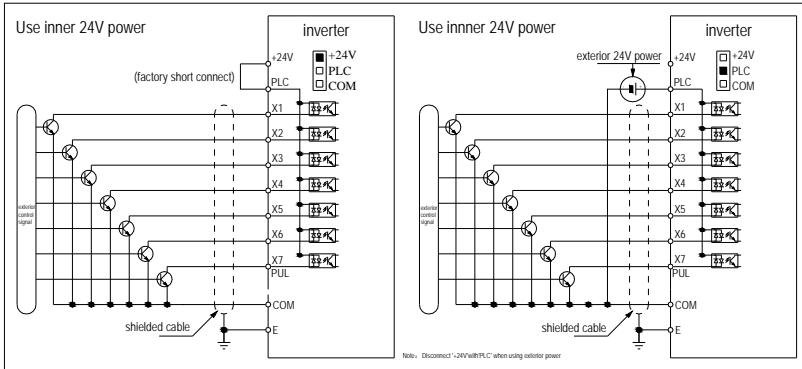

Chart 3-23: NPN Transistor Digital Input Signal Connection Mode

- PNP transistor connection mode

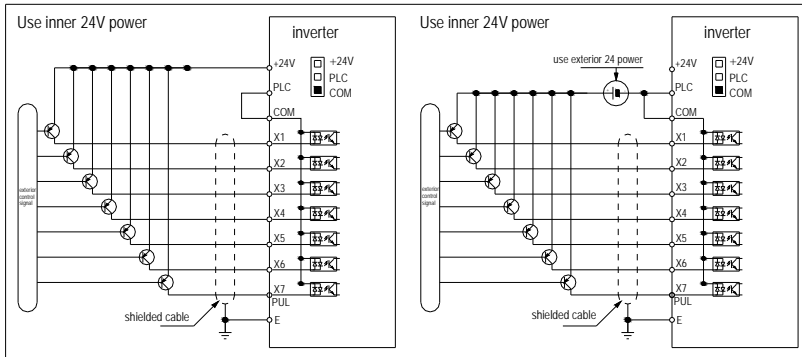

Chart 3-24: PNP Transistor Digital Input Signal Connection Mode

Digital output signal connection

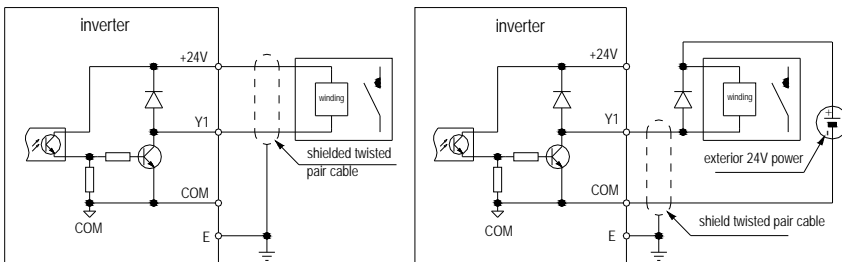

Chart 3-25: AC100 Series Inverter Digital Output Signal Connection Mode

Analog Output Signal Connection

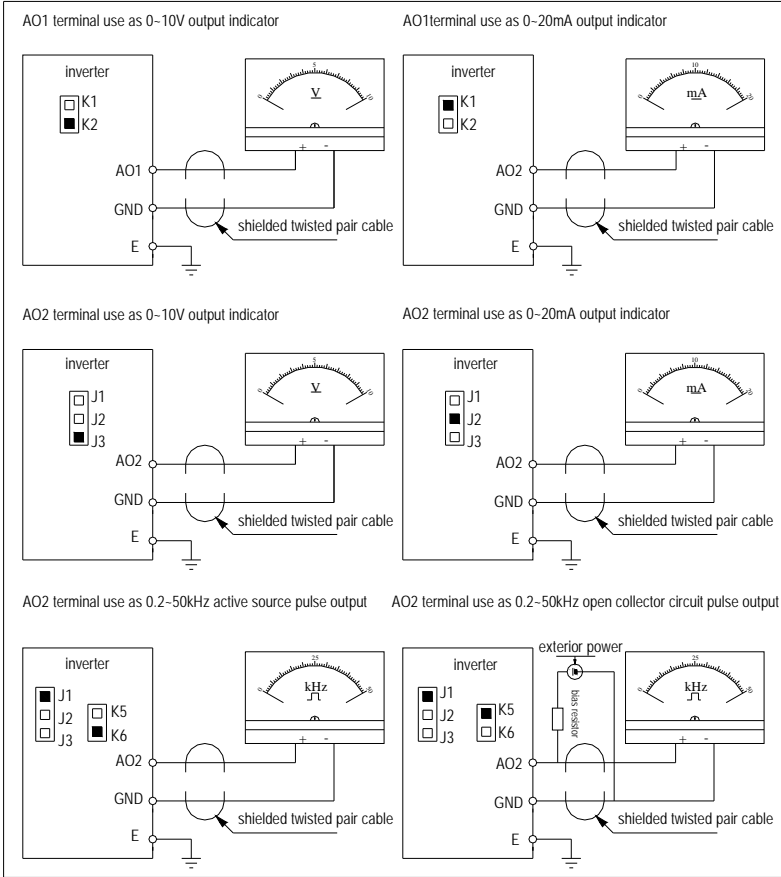

Chart 3-26: AC100 Series Inverter Analog Output Signal Connection Mode

Connection of Pulse Input Signal

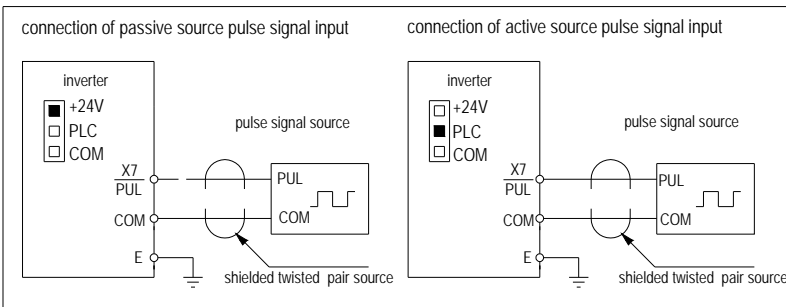

Chart 3-27: Pulse Input Signal Connection Mode of AC100 Series Inverter

Standby Control System

Frequency inverter is composed of semiconductor, passive electronic component and driving part. And these devices have working life even under normal working conditions and these devices may also have characteristic variation or failure. These characteristics change or failure would inevitably lead to failure of the product. Setting standby control system when using the inverter is highly recommended to prevent lost production caused by product failure.

Figure 3-28 is the standby control system for manual switch converting to direct driving motor of power supply when inverter fails. Standby control systems such as power supply Y/ Δ step-down start way driving motor, power supply self-coupling reduction voltage start mode driving motor, power supply soft start mode driving motor or standby inverter system can be chose to use according to the actual needs and environment.

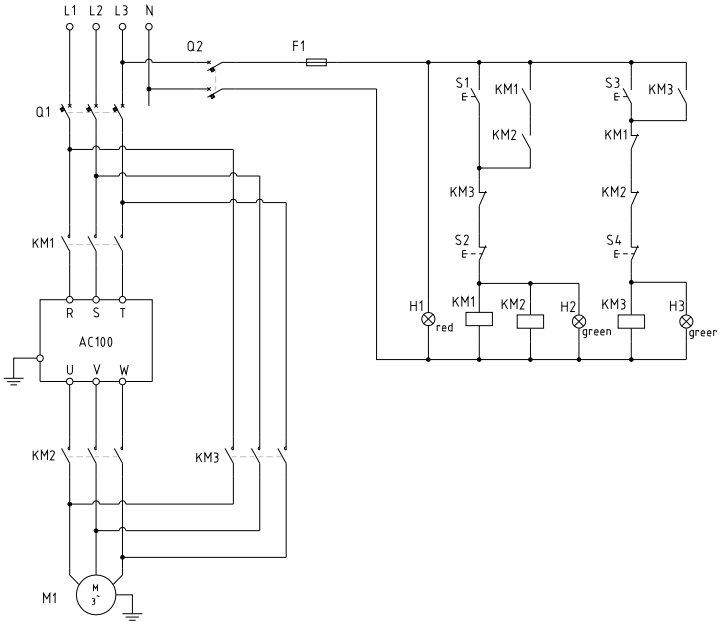





Figure 3-28: Standby Control System of Power Supply Direct Driving Mode

Chapter 4 Basic Operation and Trial Run

4.1 Safety Precautions









	<ul style="list-style-type: none"> ● No wiring while power supply is connected. Otherwise there is danger of electric shock.
	<ul style="list-style-type: none"> ● No operation when the cover is open. Otherwise, there is danger of electric shock. ● Please ensure reliable earth. Otherwise, there is danger of electric shock and fire. ● Before wiring please cut power supply of all related equipments and ensure main DC voltage in safe range. And please do operation after 5 mins. ● Only trained personnel is allowed to operate this product. ● Please do not dismantle the inverter cover when it is electrified. Otherwise, there is danger of electric shock. ● Please do not touch the printed circuit board of the inverter while it is electrified. Otherwise, there is danger of electric shock. ● Please ensure reliable mains cable connection. If the mains cable is loose, there is danger of fire caused by joint overheat. ● Before electrifying, please check the power voltage again. Wrong power voltage can cause fault or damage of the inverter, or even fire. ● Please do not install inverter on flammable material or attach flammable material to the inverter. Before electrifying, please clear the surroundings.
	<ul style="list-style-type: none"> ● When operating, please follow the ESD regulations. Otherwise, the inverter may be damaged. ● Please don't cut the power directly when the inverter drives the motor running. The power can't be cut until the motor totally stop. Otherwise, the inverter may be damaged. ● Please don't cut or connect motor when the inverter drives the motor running. The motor can't be cut or connect until the inverter output is 0. Otherwise, the inverter may be damaged. ● Control cable should be twisted-pair shielded cable. The barrier should be connected to the inverter earth terminal reliably to prevent the inverter from abnormal working. ● Unprofessional personnel can't do operation like installing, wiring, debugging or maintenance. ● Changing, dismantlement or maintenance without permission may cause inverter damage, which is not in our quality assurance range.

4.2 Keyboard Layout and Function Specification

● Keyboard Appearance



● Key Function

Key	Name	Function
	Menu key	Enter function menu when standby or running. Press this key to return when modifying parameter. Press for 1 sec to enter condition monitoring interface when in standby or running condition.
	Confirm/modify key	Press to modify parameter when in menu interface. Press again to confirm after modifying. Press to change LED monitoring items at down time when in standby or running condition.
	Up/down key	Select parameter group in menu interface. Modify parameter in modifying interface. Modify given frequency, PID, given torque or magnetic powder clutch given torque when at standby or condition monitoring state (When given frequency, PID, given torque or magnetic powder clutch given torque are set by keyboard, please set [F4.04])
	Shift key	Select digit of function number modified by up/down key; Select parameter digits modified by up/down key.
	Forward run key	When run/stop is controlled by keyboard, press this key, the inverter forwardly rotate and the indicator is always on. When reverse, the indicator sparks.
	Jog/reverse key	This key function can be defined by parameter [F4.02]. Press it, the machine reverses and indicator is off if this key is defined as REVERSE; the machine jogs and indicator is on if this key is defined as JOG.
	Stop/reset key	The machine stops if press it while run/stop is controlled by keyboard. Its efficiency range is defined via function no [F4.03]. Inverter resets if press it in fault state (the machine would not reset if the fault is not solved).
	Keyboard potentiometer	Can be used as input channel for given frequency, upper frequency limit, given torque, given PID or PID feedback setting.

● Indicator light meanings

Name	State	Meaning	
Unit Indicator Light	Hz	Spark	Digital display given frequency.
	Hz	On	Digital display output frequency.
	A	On	Digital display actual output current.
	V	On	Digital display input voltage.
	V	Spark	Digital display output voltage.
	S	On	Time unit is second.
	S	Spark	Time unit is ms, min, or h.
	RPM	On	Digital display motor speed.
	%	Spark	Digital display given PID.
	%	On	Digital display PID feedback.
State Indicator Light	FWD	On	Inverter is forwardly rotating.
	FWD	Spark	Inverter is reversely rotating.
	FWD	Off	Inverter stops.
Function indicator light	REV/JOG	On	Jog.
	REV/JOG	Off	Reverse.

Chart 4-1: Indicator Light Meanings

● Number and Character Chart

Number, character	LED display	Number, character	LED display	Number, character	LED display
0	0	C	0	O	0
1	1	D	8	P	8
2	2	E	E	Q	8
3	3	F	8	R	8
4	4	G	0	S	9
5	5	H	8	T	0
6	6	I	0	U	0
7	7	J	8	V	0
8	8	K	8	W	00
9	9	L	0	X	No display
A	8	M	00	Y	4
B	6	N	0	Z	No display

Chart 4-2: Number and Character Chart

● LCD Keyboard Function Meaning

Icon	Meaning
	Inverter at stop state
	Stand for forward running state
	Stand for reverse running state
	Stand for JOG running state
	Auxiliary sign Of reverse running state
	Remind to press "<<" button
	Remind to press "SET" button
	Cursor shift up
	Cursor shift down
	sparkling means fault state
	Reminder of what the arrow points to
	Terminal off
	Terminal on
	Two kinds of relay output: one is open while the other is close.

● Basic LED Operation

It displays frequency at 50.00Hz when stop. Here F0.09=100.00 setting is an example to explain the basic LED operation.

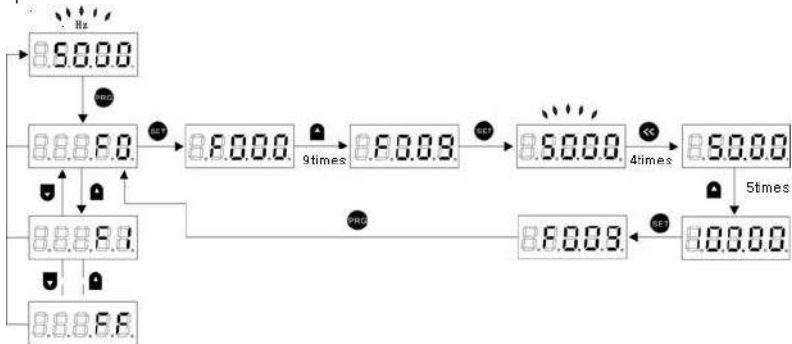

Chart 4-1: Basic LED Operation

4.3 Basic Operation

● Parameter Initialization

Set F0.19=1, and the parameter initialization is completed. Operation details as follows:

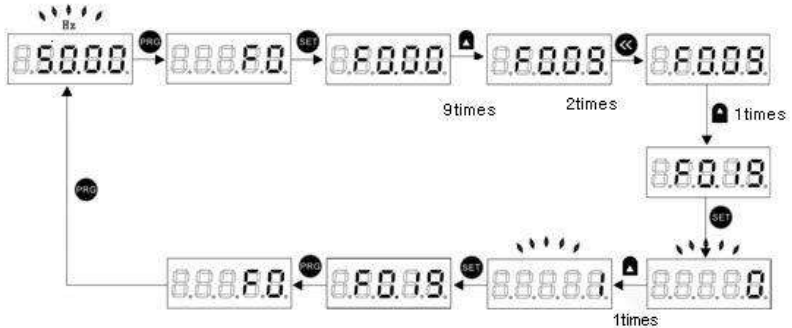

Chart 4-2: Parameter Initialization

● Control Mode Selection of Motor 1

Here we set F0.00=0 (AM VC without PG) as an example to introduce.

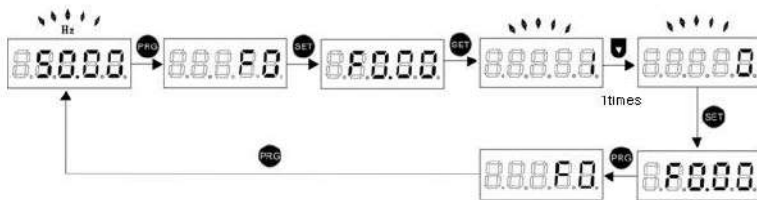

Chart 4-3: Control Mode Selection of Motor 1

● Start-up Mode Selections

Three start-up modes: 0: direct start-up, 1: braking firstly, then start by start-up frequency, 2: speed track and start-up. Here we set F1.00=2(speed track and start-up) as an example:

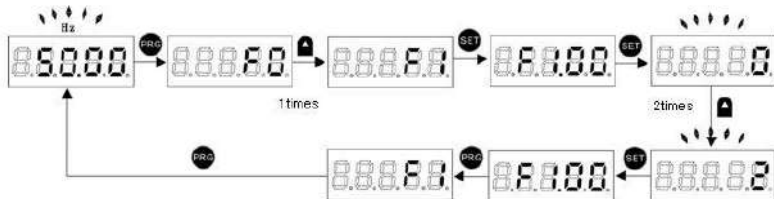

Chart 4-4: Start-up Mode Selections

● Motor Parameter Setting

Set [F5.02] (motor rated power), [F5.03] (motor rated frequency), [F5.04] (motor rated speed), [F5.05] (motor rated voltage) according to the motor nameplate. Other parameter setting can be obtained by inverter self-study.

Please refer to the following operation mode chart:

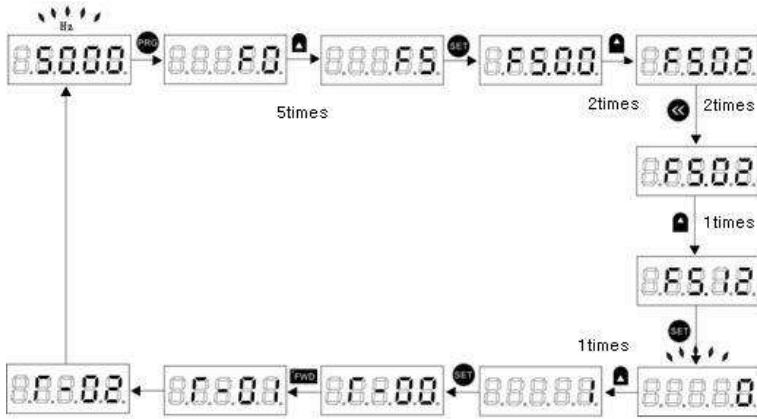

Chart 4-5: Motor Parameter Setting

● Parameter Copy Function Selection

Set F4.05=1, send inverter parameter to keyboard and save:

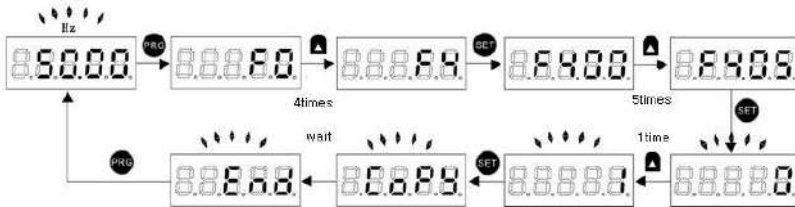

Chart 4-6: Send Inverter Parameter to Keyboard and Save

Set F4.05=2, send keyboard parameter to inverter:

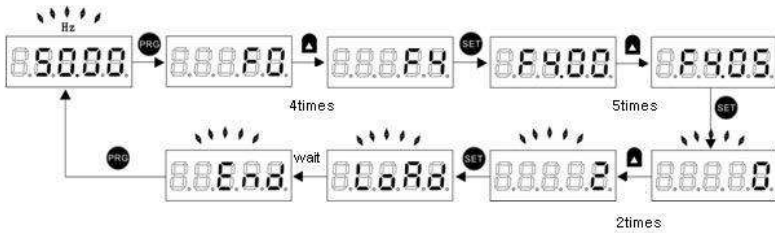

Chart 4-7: Send Keyboard Parameter to Inverter and Save

● Run Monitoring Setting

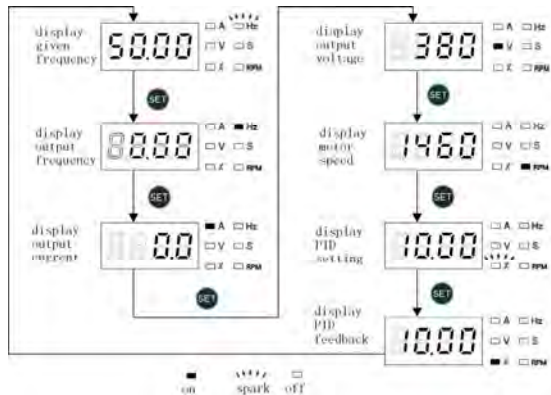

Chart 4-8: Run Monitoring Setting

4.4 LCD Keyboard Operation Instructions

● Monitoring Selection Setting Steps

Set of monitoring parameter at stop state as an example. Operations detailed in Chart 4-9. Set keyboard first-line displays when inverter stops under function parameter F4.11. Factory setting includes four-group parameters such as input frequency, output frequency, output current and input voltage. Press **SET** to change display content when inverter stops. Press **<<** to change displays of uplink monitoring parameter group.

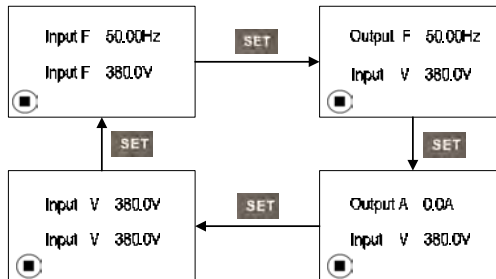

Chart 4-9: Display Change of Uplink Monitoring Parameter Group

● Operation Process of Fault Display

Operation of rectifier bridge overheat fault display as an example, details in Chart 4-10. When keyboard displays fault, please press **SET** to check fault reasons, and press **PRG** to return back. Press **▲** and **▼** to check other fault reasons. Press **STOP/RESET** to reset fault in whole operation.

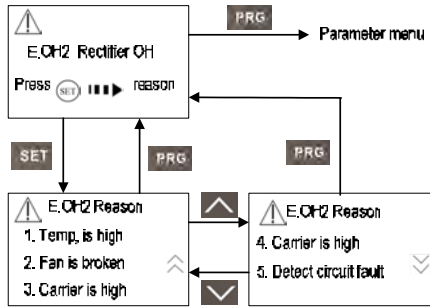

Chart 4-10: Rectifier Bridge Fault Display

● Operations of Third-level Menu

(1) Operation process of changing lines: Operation of parameter initialization under function code of F0.19 as an example; set F0.19=1, and the parameter initialization is completed. Details in Chart 4-11.

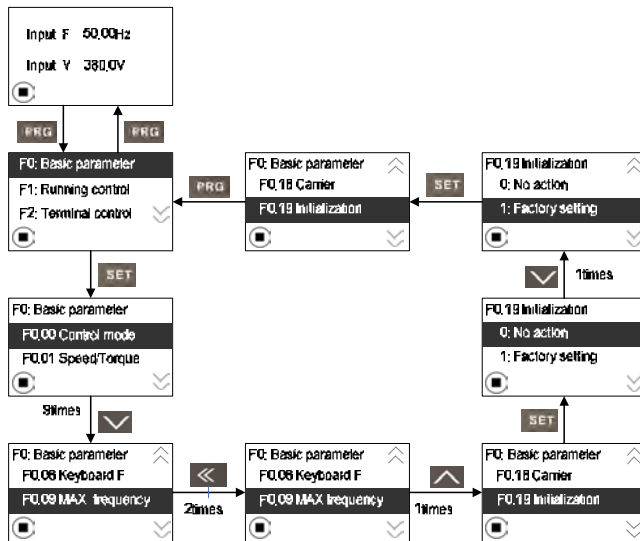

Chart 4-11: Operations Process of Changing Lines

(2) Operation process of data modifying: Setting of main channel gain under function code of F0.04 as an example; set F0.04=2.000%. Details in Chart 4-12.

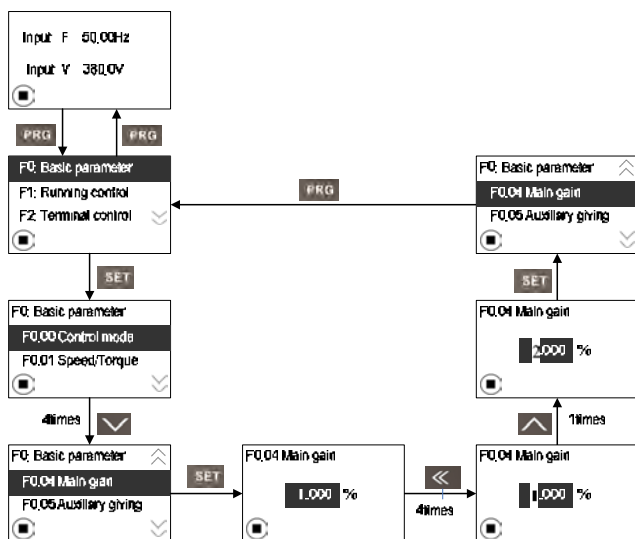

Chart 4-12: Operation Process of Data Modifying

(3) Operation process of groups: Setting carrier frequency characteristic under function code of F0.08. Set '1. Related to output frequency' in group 2, Details in Chart 4-13.

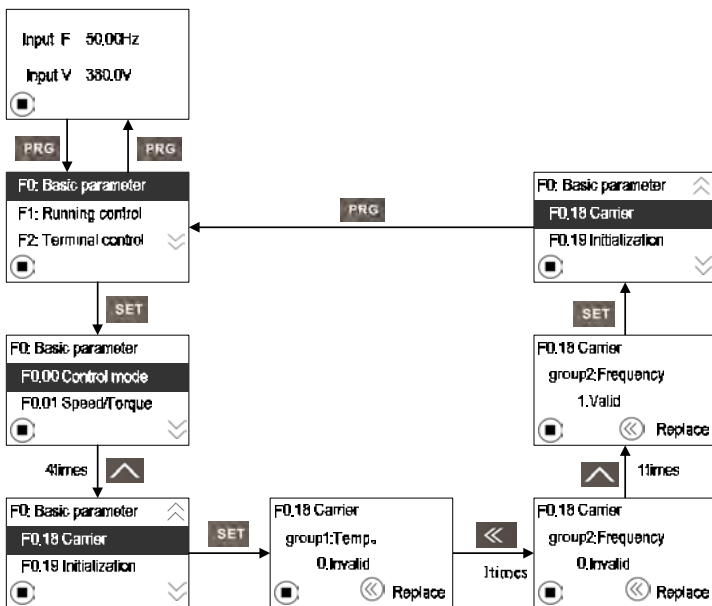

Chart 4-13: Operation Process of Groups

● Operation Process of Parameters Copy

Operation process of parameters copy in Chart 4-14; download process in Chart 4-15.

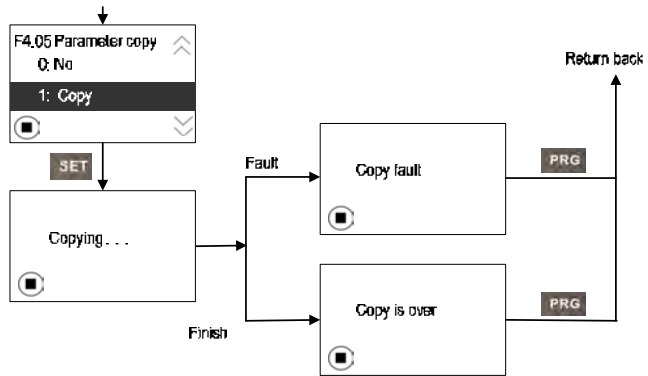

Chart 4-14: Operations of Parameter Copy

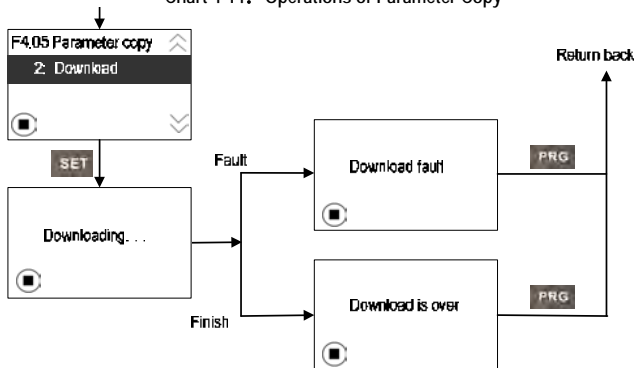

Chart 4-19: Operations of Parameter Download

● Operation Process of Motor Parameter Self-tuning

Operations of rotary type self-tuning in Chart 4-16; Static type self-tuning in Chart 4-17.

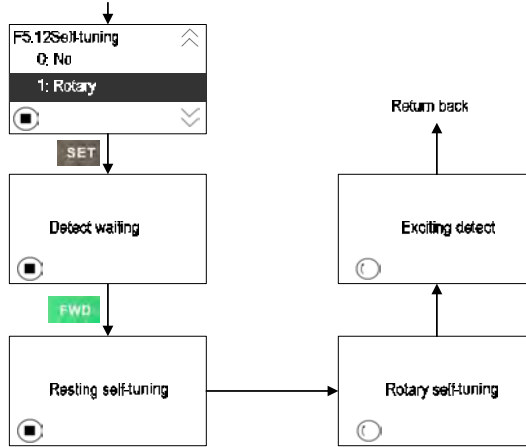

Chart 4-16: Operations of Rotary Type Self-tuning

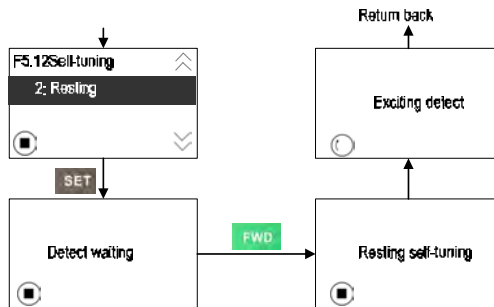

Chart 4-17: Operations of Static Type Self-tuning

4.5 Trial run

● Frequency Giving Process

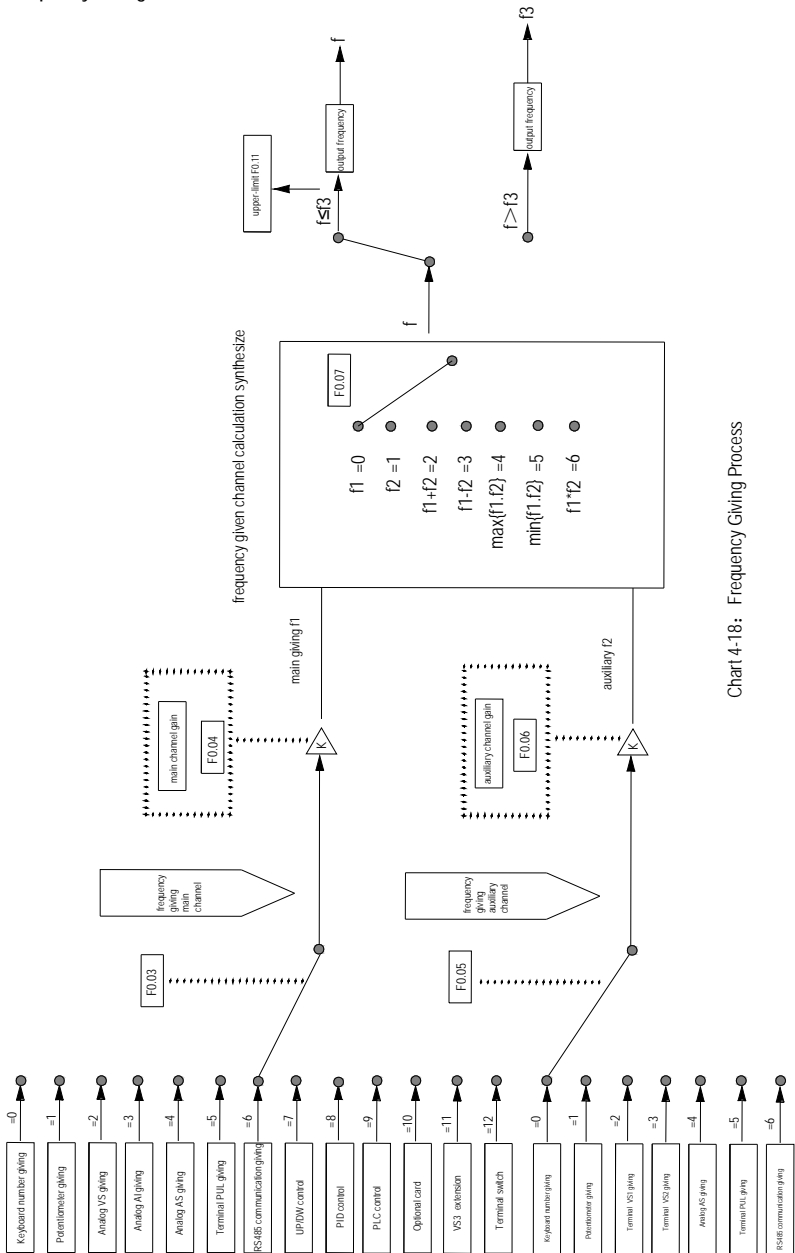

Chart 4-18: Frequency Giving Process

● Start/Stop Control Process

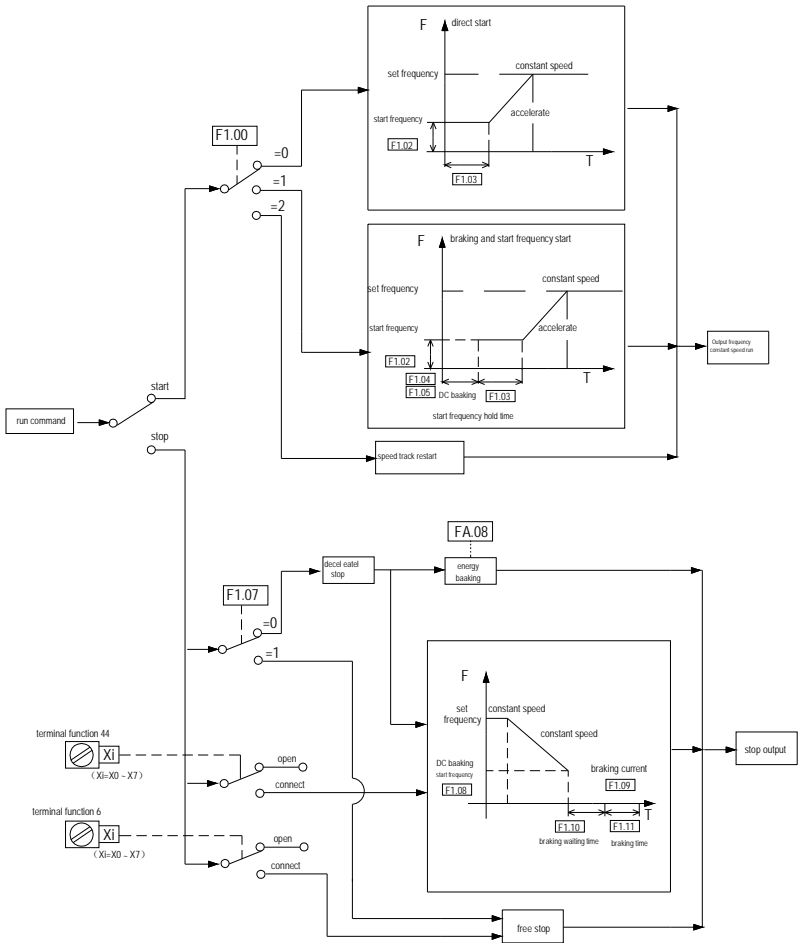

Chart 4-19: Start/Stop Control Process

● Commissioning Debugging Guide

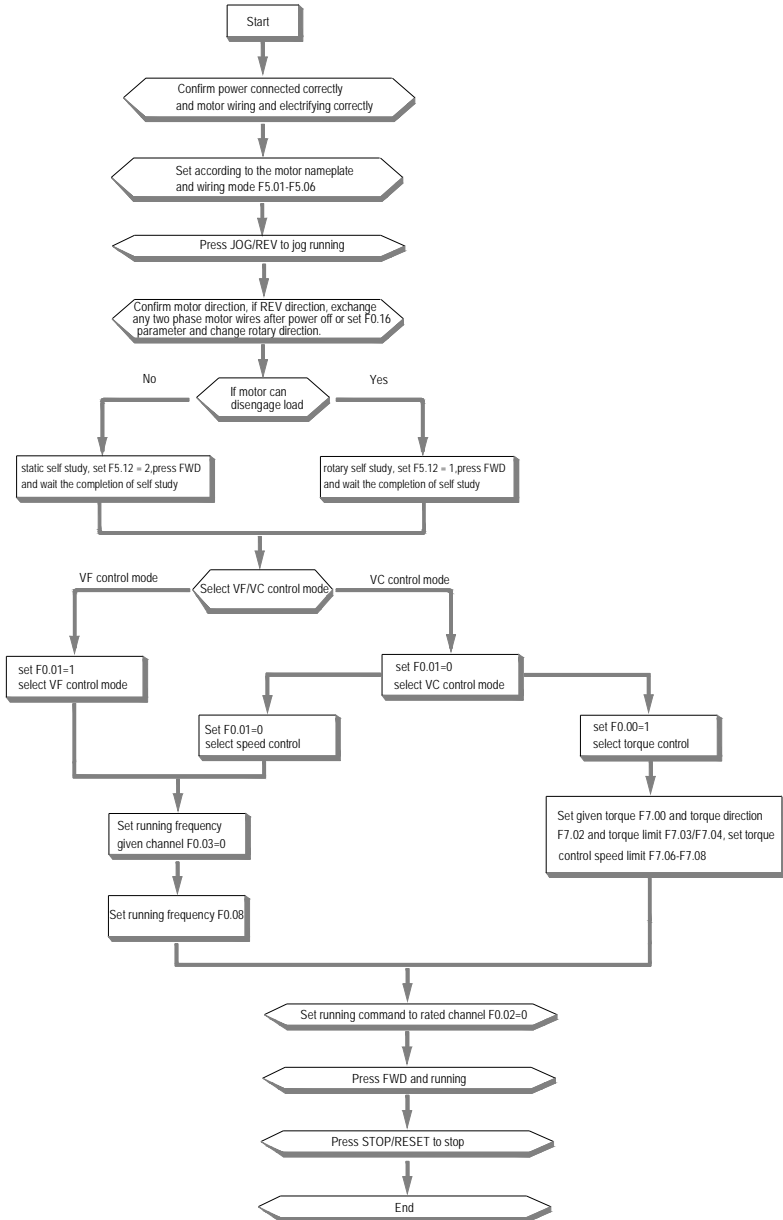

Chart 4-20: Commissioning Debugging Guide

● parameters self tuning

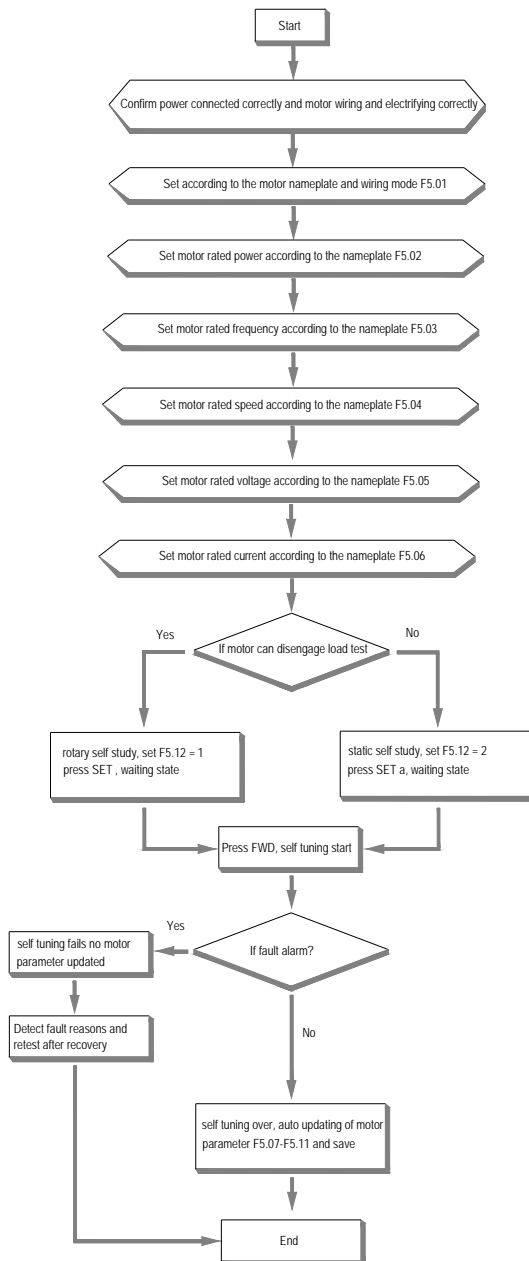

Chart 4-21: motor parameter self tuning

● asynchronous motor VF debugging procedure

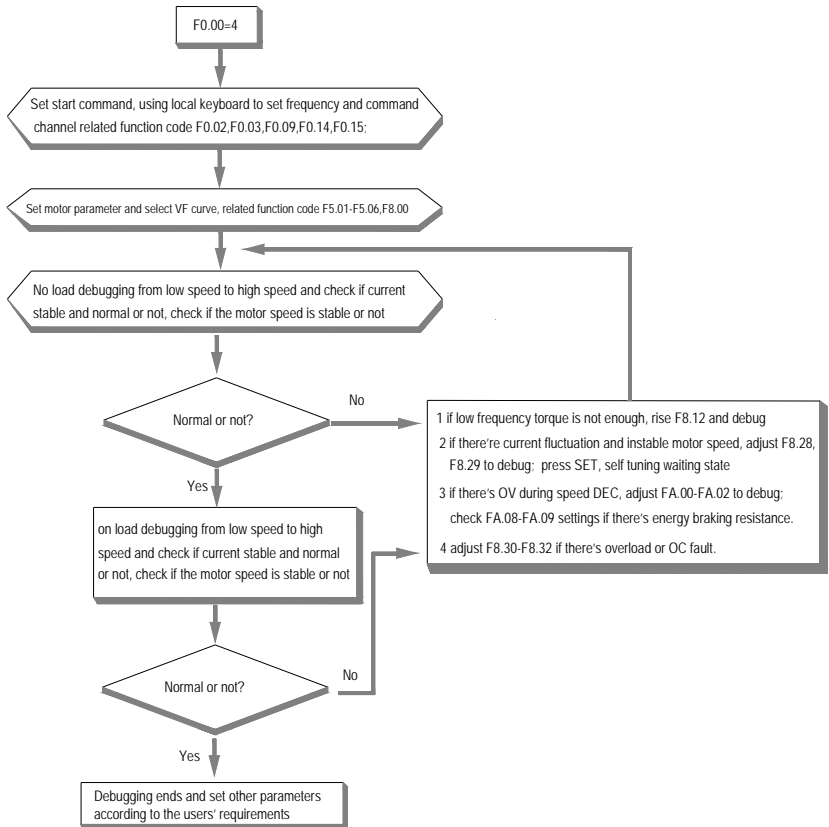

Chart 4-22 asynchronous motor VF debugging procedure

● asynchronous motors or synchronous motor VC control debugging procedure

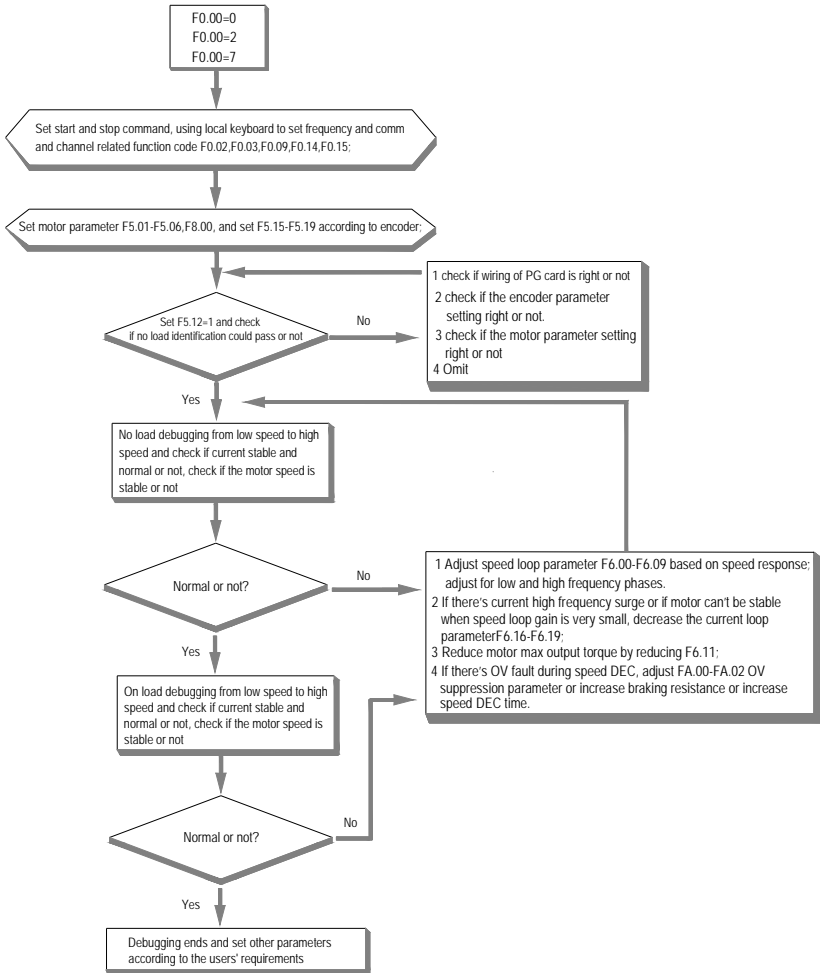

Chart 4-23 motor VC control debugging procedure

● asynchronous motors or synchronous motor torque control debugging procedure

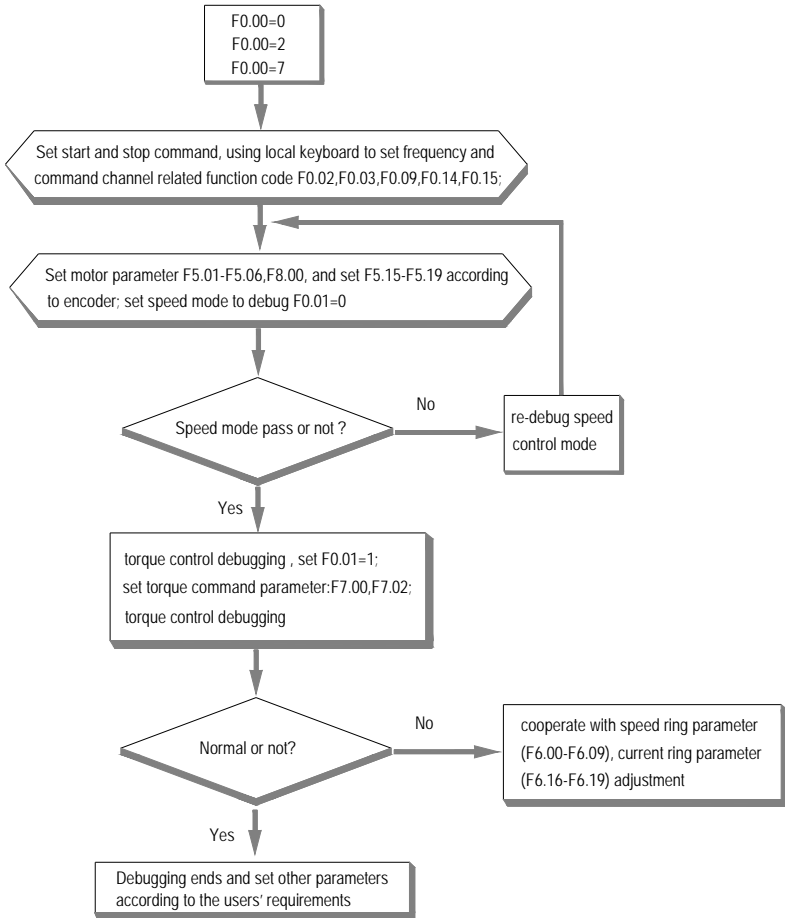

Chart 4-24 motor torque control debugging procedure

● synchronous motor PG vector control debugging procedure

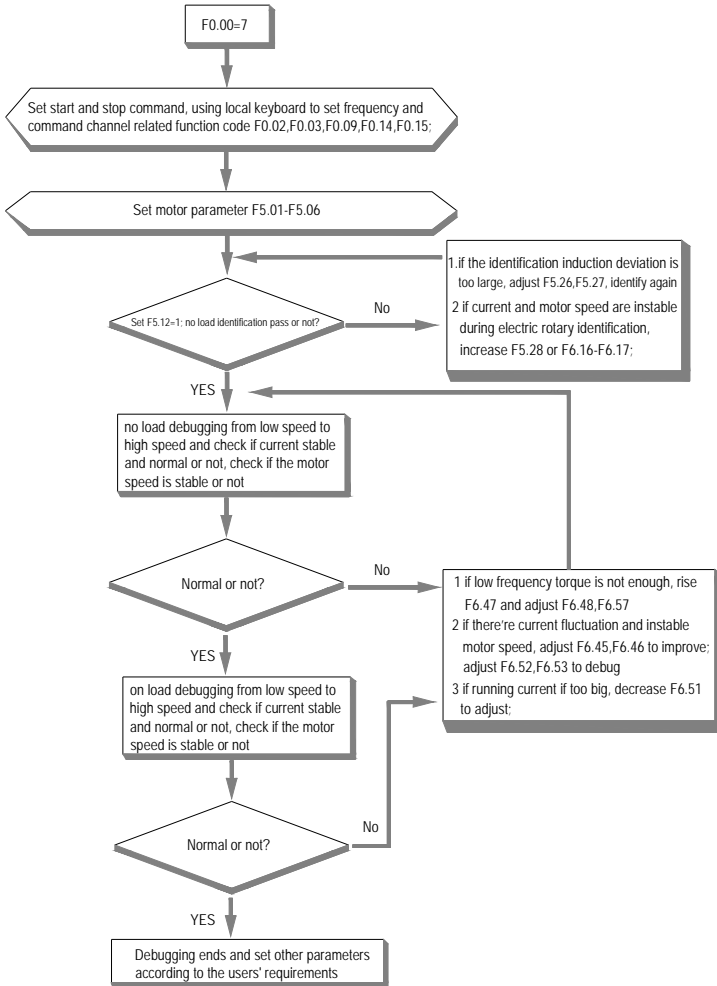

Chart 4-25: synchronous motor PG vector control debugging procedure



Chapter 5 Fault Diagnoses and Treatment Measures

This chapter explains the display content and measures of the inverter fault, alarm and operation fault. In addition, the poor condition caused by the inverter and motor failures and the corresponding processing measures will be briefly described. Tuning Guide on trial use is also referred to in this chapter

5.1 Fault Types











Type	Inverter Action When Fault Happens
Equipment Fault	<p>When inverter detects a fault, the following conditions would happen:</p> <ul style="list-style-type: none"> ● Keyboard display character showing fault content. ● Inverter output stops. Motor free slide stops. ● When function [F2.29] is 3(output fault), Y terminal outputs valid open-collector digital output. ● When function [F2.30/F2.31] is 3(fault output), TA1-TC1, TA2-TC2 terminals output open passive digital output. ● For faults like OL, OC, SC, OV, UL2, if [FA.22] is not 0, the inverter will restart automatically after the time interval set by [FA.23].
External Fault	<p>In certain application occasions, external related equipments fault signals are considered in the inverter control system as usage of monitoring, protection and switch control. At this time, if one multi function terminal is defined as "external fault", and when the external related equipments fault signals are effective, the inverter stops output and give out alarm signal.</p>

5.2 Fault Information and Details

Keyboard Display	Fault Code	Fault Type	Possible Causes	Treatment Measures
	L.U.1	Too low when stop	<ul style="list-style-type: none"> ● Power supply is too low ● Voltage detection circuit is abnormal 	<ul style="list-style-type: none"> ● Check input power, eliminate fault. ● Seek support from vendor.
	E.LU2	Under voltage in run	<ul style="list-style-type: none"> ● Power supply is too low ● Power capacitance is too small, or there is enormous impact current in the power grid. ● Inner DC main contactor is not closed. 	<ul style="list-style-type: none"> ● Check input power, eliminate fault. ● Improve power-supply system. ● Seek support from vendor.
	E.oU1	Acc overvoltage	<ul style="list-style-type: none"> ● Power voltage fluctuation over limit. ● Start motor when running. 	<ul style="list-style-type: none"> ● Detect power voltage and eliminate fault. ● Restart motor until it totally stop; Set F1.00 to 1or 2.

E.oU2	E.oU2	Dec overvoltage	<ul style="list-style-type: none"> ● Deceleration time is too short. ● Load potential energy or inertia is too large. ● Power voltage fluctuation over limit. 	<ul style="list-style-type: none"> ● Prolong deceleration time properly. ● Reduce load inertia or improve inverter capacitance or add braking unit. ● Detect input power and clear fault.
E.oU3	E.oU3	Constant speed over-voltage	<ul style="list-style-type: none"> ● Power voltage fluctuation over limit. 	<ul style="list-style-type: none"> ● Detect input power voltage and eliminate fault. ● Install input reactor.
E.oU4	E.oU4	Over-voltage when stop	<ul style="list-style-type: none"> ● Power voltage fluctuation over limit. 	<ul style="list-style-type: none"> ● Check input power, eliminate fault. ● Seek support from vendor.
E.oC1	E.oC1	Acc over-current	<ul style="list-style-type: none"> ● Acceleration time is too short. ● Start motor when running. ● V/F curve setting is not suitable. Or torque boost too high. ● Inverter capacitance is too small. 	<ul style="list-style-type: none"> ● Prolong acc time. ● Restart motor until it totally Stop; Set F1.00 to 1or 2. ● Reset V/F curve or torque boost value. ● Select inverter with right capacitance.
E.oC2	E.oC2	Dec over-current	<ul style="list-style-type: none"> ● Deceleration time is too short. ● Load potential energy or inertia is too large. ● Power voltage fluctuation over limit. 	<ul style="list-style-type: none"> ● Prolong deceleration time. ● Connect external braking resistance or braking unit. ● Select inverter with right capacitance.
E.oC3	E.oC3	Constant speed over-current	<ul style="list-style-type: none"> ● Sudden load change. ● Power grid voltage is too low. 	<ul style="list-style-type: none"> ● Check load change and eliminate it. ● Check input power, eliminate fault.
E.oL1	E.oL1	Motor over-load	<ul style="list-style-type: none"> ● V/F curve setting is not suitable. Or torque boost too high. ● Power grid voltage is too low. ● Wrong overload protection setting. ● Locked-rotor run or too heavy load. ● Universal motor runs at low speed for a long time 	<ul style="list-style-type: none"> ● Reset V/F curve or torque boost value. ● Check input power, eliminate fault. ● Unreasonable F5.06 setting. ● Adjust load or select inverter with right capacitance. ● If long-term low-speed operation is needed, please choose special motor for inverter.

E.oL2	E.oL2	Inverter over-load	<ul style="list-style-type: none"> ● Load is too heavy. ● Acceleration time is too short. ● Start motor when running. ● V/F curve setting is not suitable. Or torque boost too high. 	<ul style="list-style-type: none"> ● Select inverter with right capacitance. ● Prolong acceleration time ● Restart motor until it totally stops. Set [F1.00] as 1or2. ● Reset V/F curve or torque boost value.
E.SC	E.SC	System abnormal	<ul style="list-style-type: none"> ● Acceleration time is too short. ● Short circuit between inverter output phases or earth. ● Module is damaged. ● Electromagnetic disturb. 	<ul style="list-style-type: none"> ● Prolong acceleration time properly. ● Check peripheral equipments and restart after fault eliminating. ● Seek support from vendor. ● Check system wiring, earth, shield and deal as required.
E.oH1	E.oH1	Inverter over-heat	<ul style="list-style-type: none"> ● Temperature is too high. ● Air channel is blocked. ● Fan connection parts loose. ● Fan is damaged. ● Temperature detection circuit fault 	<ul style="list-style-type: none"> ● Meet the environment requirement. ● Clear the air channel. ● Check and reconnect the wire ● Change the same new fan. ● Seek support from vendor.
E.oH2	E.oH2	Rectifier over-heat	<ul style="list-style-type: none"> ● Temperature is too high. ● Air channel is blocked. ● Fan connection parts loose. ● Fan is damaged. ● Temperature detection circuit fault 	<ul style="list-style-type: none"> ● Meet the environment requirement. ● Clear the air channel. ● Check and reconnect the wire. ● Change the same new fan. ● Seek support from vendor.
E.Fb1	E.Fb1	PID feedback over upper limit	<ul style="list-style-type: none"> ● PID feedback wire breaks. ● PID feedback channels parameter is wrong. ● Analog feedback channel is abnormal. 	<ul style="list-style-type: none"> ● Check PID feedback wire. ● Check the PID feedback channel parameter setting. ● Seek support from vendor.
E.Fb2	E.Fb2	PID feedback over lower limit	<ul style="list-style-type: none"> ● PID feedback wire breaks. ● PID feedback channels parameter is wrong. ● Analog feedback channel is abnormal. 	<ul style="list-style-type: none"> ● Check PID feedback signal wire. ● Check the PID feedback channel parameter setting. ● Seek support from vendor.
E.TE1	E.TE1	Motor static detection fault	<ul style="list-style-type: none"> ● Detection overtime ● Start static detection when motor is running. ● Capacitance difference is too big between motor and inverter. 	<ul style="list-style-type: none"> ● Check motor connection wire. ● Detect after motor stops totally. ● Change inverter model. ● Reset parameter according to nameplate.

			<ul style="list-style-type: none"> ● Motor parameter setting mistake. 	
	E.TE2	Motor rotation detection fault	<ul style="list-style-type: none"> ● Detect when motor is running. ● Detect with load. ● Detection overtime ● Capacitance difference is too big between motor and inverter. ● Motor parameter setting mistake. 	<ul style="list-style-type: none"> ● Detect after motor stops totally. ● Re-detect without load. ● Check motor connection wire. ● Change inverter model. ● Reset parameter according to nameplate.
	E.EEP	Storage failure	<ul style="list-style-type: none"> ● Electromagnetic disturb in storage period. ● EEPROM damage. 	<ul style="list-style-type: none"> ● Resume load and save. ● Seek support from vendor.
	LIFE	Reserved	<ul style="list-style-type: none"> ● 	<ul style="list-style-type: none"> ● Seek support from vendor.
	E.ILF	Input side open phase	<ul style="list-style-type: none"> ● 3-phase input power open phase. 	<ul style="list-style-type: none"> ● Check 3-phase power supply and the phase. ● Check 3-phase power supply wiring.
	E.oLF	Output side open phase	<ul style="list-style-type: none"> ● 3-phase output power open phase 	<ul style="list-style-type: none"> ● Check 3-phase output voltage and current. ● Check wiring.
	E.Gnd	Output earth	<ul style="list-style-type: none"> ● Output earth terminal short circuit. 	<ul style="list-style-type: none"> ● Check wiring and insulation.
	E.HAL	Current detection fault	<ul style="list-style-type: none"> ● Detect circuit fault. ● Phase imbalance 	<ul style="list-style-type: none"> ● Seek for technical support. ● Check motor and wiring.
	E.EF	Inverter external fault	<ul style="list-style-type: none"> ● Peripheral equipment fault protection. 	<ul style="list-style-type: none"> ● Check peripheral equipment.
	E.PAn	Keyboard connect fault	<ul style="list-style-type: none"> ● Keyboard wire fault. ● Keyboard component damage. 	<ul style="list-style-type: none"> ● Check keyboard wire. ● Seek support from vendor.
	E.CE	Rs485 communication fault	<ul style="list-style-type: none"> ● Unsuitable baud rate setting. ● Communication wire breaks. ● Communication format does not match upper machine. 	<ul style="list-style-type: none"> ● Set suitable baud rate setting. ● Check communication wire. ● Set right communication format.
	E.CPE	Parameter copy fault	<ul style="list-style-type: none"> ● Parameter copy communication is fault. ● Copy keyboard is not match the inverter. 	<ul style="list-style-type: none"> ● Check wire. ● Select the specified external keyboard model.

E.ECF	E.ECF	Extend card connection fault	<ul style="list-style-type: none"> ● Communication between extend card and frequency inverter overtime. ● Extended card does not match with frequency inverter. 	<ul style="list-style-type: none"> ● Check connector, and re-insert wire. ● Choose the named card.
E.PG	E.PG	PG card connection abnormal	<ul style="list-style-type: none"> ● PG card and inverter connection failure 	<ul style="list-style-type: none"> ● Check the connection
E.P.d	E.PID	PID feedback failure	<ul style="list-style-type: none"> ● PID feedback upper limit of disconnection alarm is improper ● PID feedback lower limit of disconnection alarm is improper ● PID feedback wiring unreliable ● Sensor with feedback failure ● Feedback input loop failure 	<ul style="list-style-type: none"> ● Confirm the sensor state, if broken, change it. ● Repair the wiring. ● Confirm the setting value of [Fb.16] and [Fb.17].

Chart 5-1: Fault Information and Details

5.3 Fault Diagnoses Process

System Fault Diagnose Process

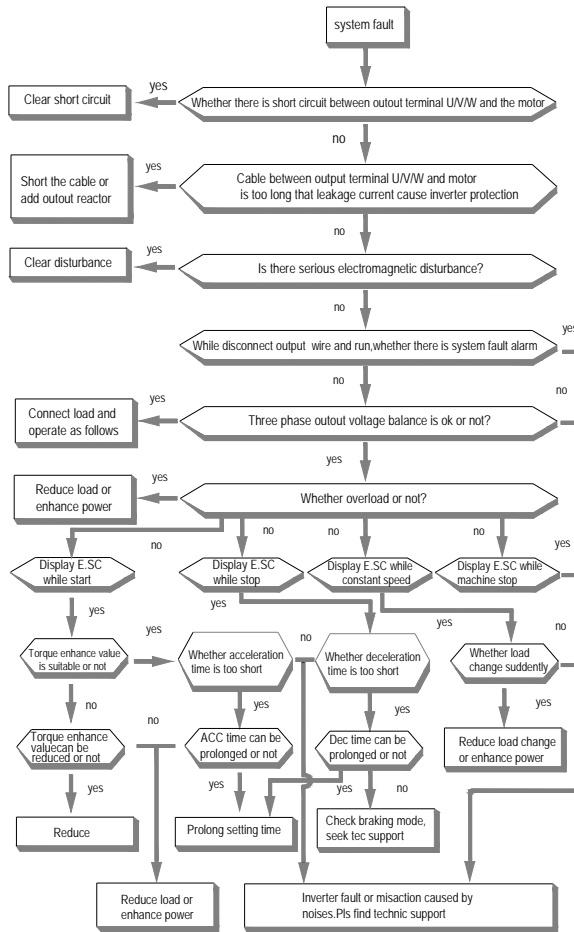

Over Current Diagnose Process

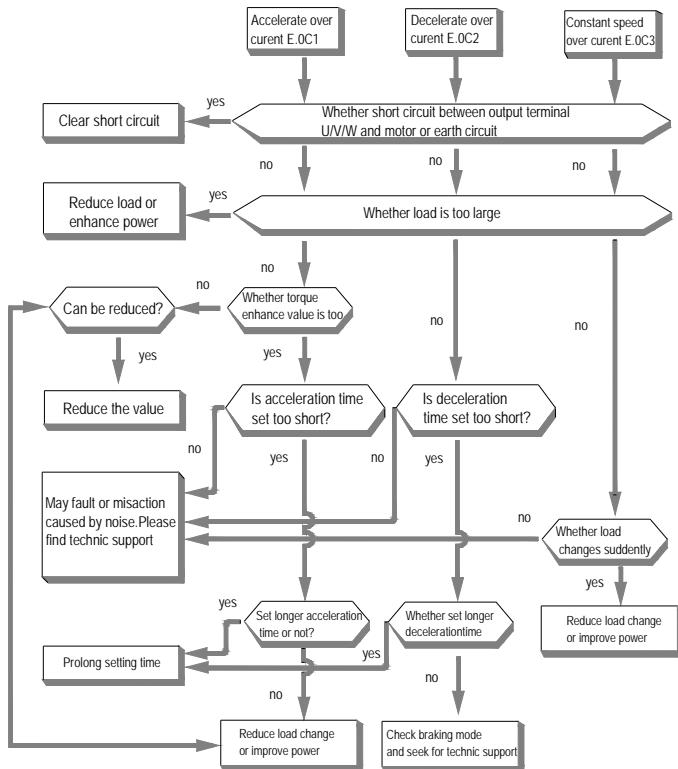

Diagnose Process For Over Voltage

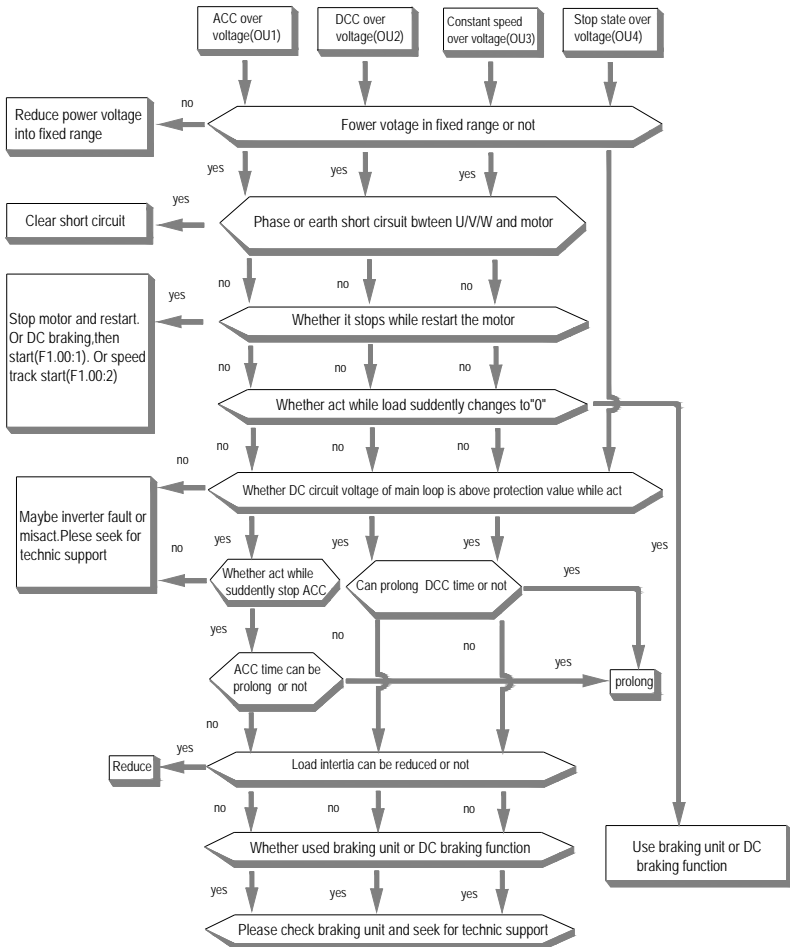

Diagnose Process When Power Supply Voltage is Too Low

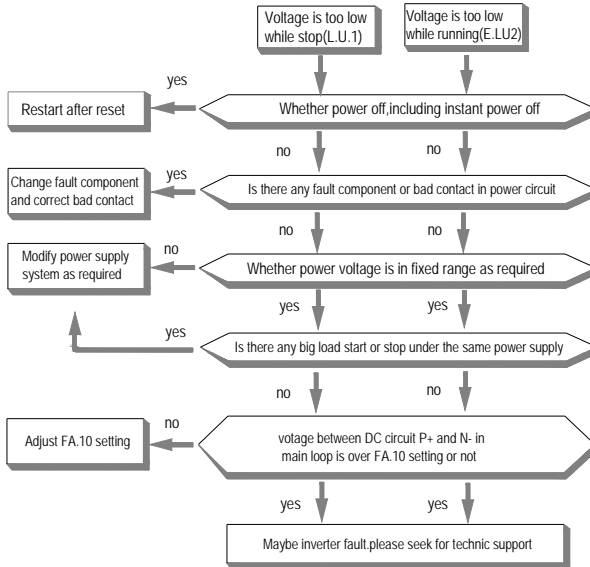

Diagnose Process for Inner Inverter Overheat

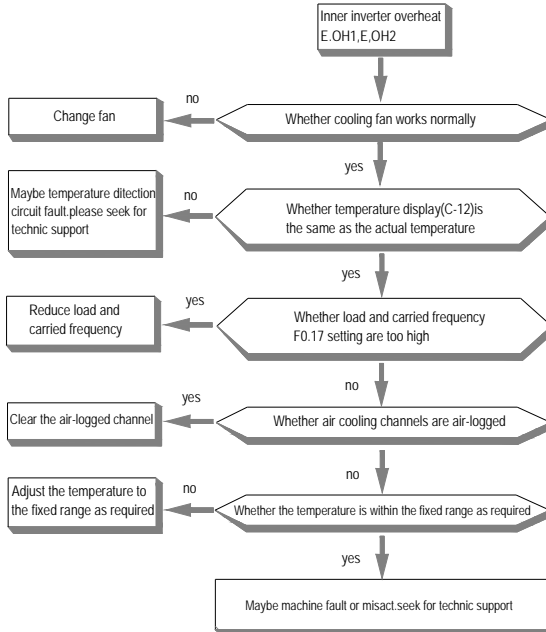

Diagnose Process for Overload

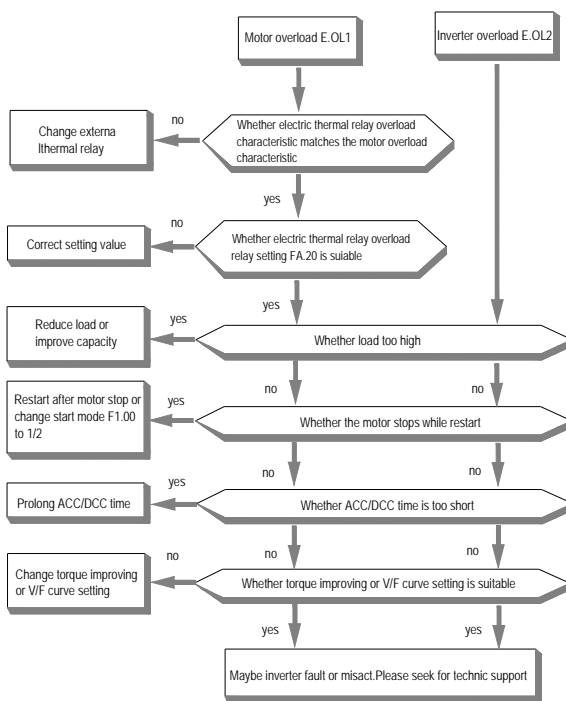

Diagnose Process for No Display

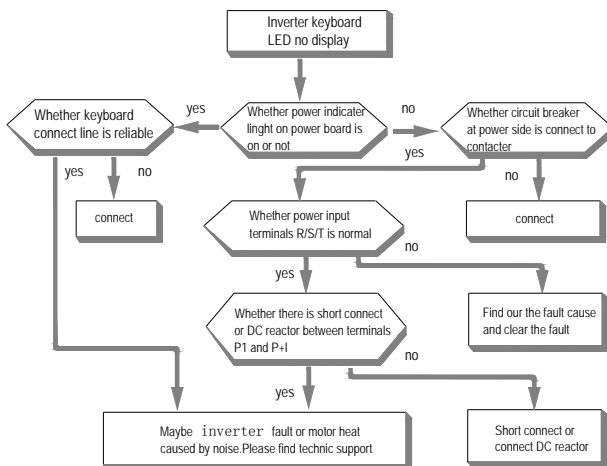

Diagnose Process for Motor Heating

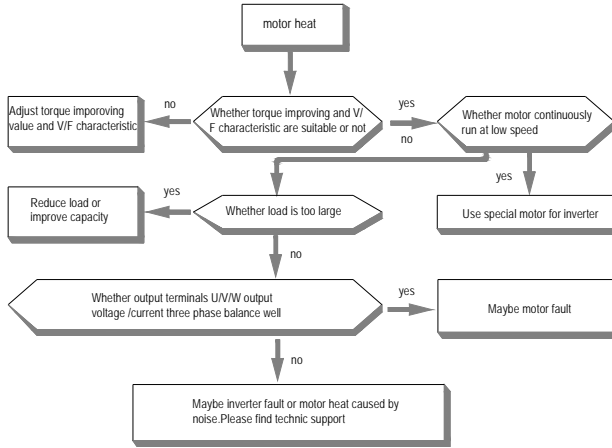

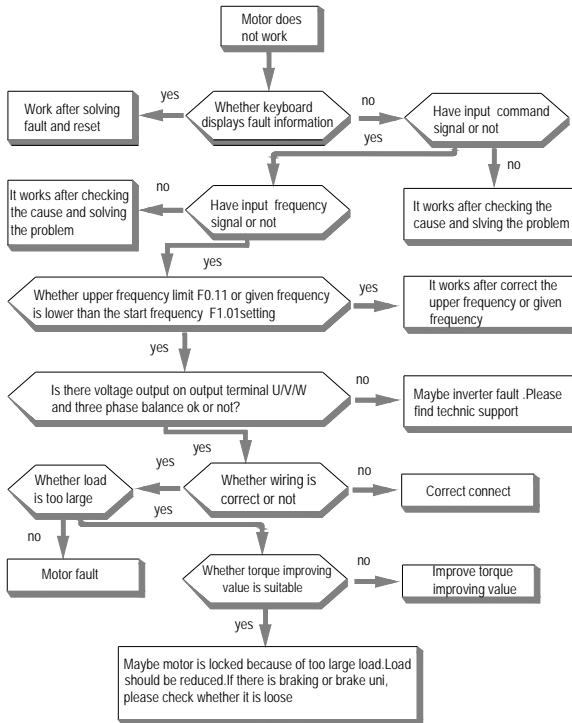

Diagnose Process When Motor Does Not Rotate



Chapter 6 Regular Inspection and Maintenance

6.1 Safety Precautions

This chapter explains the safety rules in inspection and maintenance.

	<ul style="list-style-type: none"> ● No operation under power connecting state. Otherwise, there is danger of electric shock even death. ● Before operation, please cut all related equipments power, ensure that the main circuit DC current has dropped to safe range. And please operate after 5 mins.
	<ul style="list-style-type: none"> ● No operation when cover/panel is dismantled. Otherwise there is danger of electric shock. ● Do not dismantle the cover or PCB under power connected state. Otherwise there is danger of electric shock death. ● Only professional personnel can maintain or change fittings. Otherwise, there might be danger. ● Do not wear loose clothes when installing, debugging or maintaining. Related protective tools and safeguard should be adopted. ● Tighten screw with specified torque. If main circuit wire connection is loose, there is danger of overheat fire. ● Machine and motor earth must be reliable. Otherwise, there is danger of electric shock when touching the motor cover.
	<ul style="list-style-type: none"> ● When operation, please follow the ESD regulations. Otherwise, the inverter may be damaged. ● Do not change the circuit or structure of the inverter. Otherwise, the inverter may be damaged. ● Please confirm the rotate direction when no-load. Wrong direction can cause body injury or Significant property damage. ● Do not use damaged machine. Otherwise, there is danger of accident.

6.2 Inspection

Frequency inverter is composed of semi-conductive components, passive electronic component and motive component. All of these components have useful life even under normal working environment, and some of the components can't work after the life time. There must be maintenance measures such as daily check, regular inspection and component changing to protect the components. We suggest one regular inspection every 3-4 months after installation. The inspection period should be shortened in following situations:

- High temperature, high altitude;
- Start and stop frequently;
- AC power supply or load fluctuates obviously;
- Environment with serious vibration or impact;
- Environment with dust, metal dust, salt, vitriol, chlorine;
- Poor storage environment;

● Daily Checking

To avoid machine damage and to prolong life time, please check the following items every day.

Items	Checking Content	Treatment Measure
Power supply	Check if power supply meets the requirement and if there is lack-phase.	Solve according to requirements on nameplate.

Surroundings	Check if it meets the requirement of table3-1.	Find out the problem and solve it.
Cooling system	Check if the inverter or the motor heat or change color abnormally and cooling fan working state.	Check if it overloads. Tighten screw. Check if cooling fan is dirty or stall rotate.
Motor	Check if there is abnormal vibration or noise.	Tighten machine and electric connection and lubricate the machine components.
Load	Check if output current is over the rated value of the motor or the inverter and has lasted for a period.	Check if it overloads and if the machine model is right.



No operation under power connecting state. Otherwise, there is danger of electric shock even death.

Before operating, please cut all related equipments power, ensuring that the main circuit DC current has dropped to safe range. And please operate after 5 mins.

● Regular Inspection

On normal cases, do one inspection every 3 or 4 months. Please decide the actual inspection period according to the machine use condition and working circumstance when using the machine.

● Main Circuit

Items	Checking Content	Treatment Measure
Overall	Check insulated resistance; Check environment.	Tighten and change bad component; Clear and improve circumstance.
Electric connection	<ul style="list-style-type: none"> ● Check if the color of wire and connector changes and if there is disrepair, crack color change or aging in insulating layer. ● Check if the connect terminals are frayed, damaged or loose. ● Earth checking. 	<ul style="list-style-type: none"> ● Change bad wire. ● Fasten terminals and change bad terminals. ● Measure earth resistance and fasten earth terminals.
Mechanical connection	<ul style="list-style-type: none"> ● Check if there is abnormal vibration or noise or anything loose. 	<ul style="list-style-type: none"> ● Tighten, lubricate and change the bad components.
Semi-conductive component	<ul style="list-style-type: none"> ● Check if there is dust or rubbish. ● If there is obvious change of appearance? 	<ul style="list-style-type: none"> ● Clean operation environment ● Change damaged component
Electrolytic capacitor	<ul style="list-style-type: none"> ● If there is liquid leak, color change or crack. If the safety valve outcrop, inflation, creak or liquid leak. 	<ul style="list-style-type: none"> ● Change damaged component
Peripheral equipment	<ul style="list-style-type: none"> ● Peripheral equipment outlook and insulation checking. 	<ul style="list-style-type: none"> ● Clear and change damaged component.
PCB	<ul style="list-style-type: none"> ● check if there're peculiar smell, color change or bad rust and check if the connection is right. 	<ul style="list-style-type: none"> ● Fasten connector ● Clear PCB ● Change damaged PCB
Cooling system	<ul style="list-style-type: none"> ● Check if the fan is damaged or blocking. ● If rubbish and dust is stick to the heat sink. 	<ul style="list-style-type: none"> ● Clean operation environment ● Change damaged component.

	<ul style="list-style-type: none"> ● Is air inlet/outlet blocked? Or is there something sticking to the inlet/outlet. 	
Keyboard	<ul style="list-style-type: none"> ● If it is damaged. Check if display is complete. 	<ul style="list-style-type: none"> ● Change damaged component
Motor	<ul style="list-style-type: none"> ● Check if there is abnormal vibration or noise. 	<ul style="list-style-type: none"> ● Tighten machine and electric connection and lubricate the machine components.

No operation under power connecting state. Otherwise, there is danger of electric shock even death.



Before operating, please cut all related equipments power, ensure that the main circuit DC current has dropped to safe range. And please operate after 5 mins.

6.3 Maintenance

All equipments and components have useful life. Right maintenance can prolong the lifetime. But damage can't be avoided. Please change the components before their lifetime is over.

Component	Useful Lifetime
Fan	2-3year
Electrolytic Capacitor	4-5 year
PCB	8-10 year

● Fan



When changing fan, please use original fan. You can contact the dealer or the sales department of Veichi Company. For those inverter models equipped with many fans in one machine, to prolong these machines' lifetime, changing all fans when changing the cooling fan is highly recommended.

● Fan Change Method:

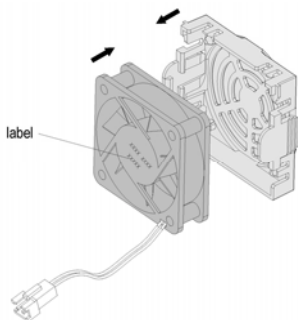

1. Install the fan vertically into the cover as shown in the picture (the nameplate label should face the outside).

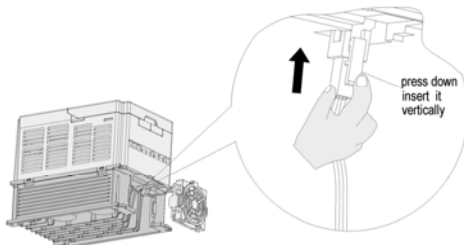

2. Press the elastic clip of the fan by finger toward the inner side and insert the leading wire terminal of the fan vertically slightly.

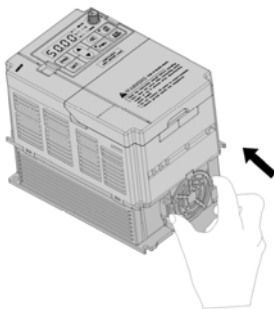

3. Insert the two elastic clips of the fan cover vertically into the fan installation slots.

● **Fan Dismantlement:**

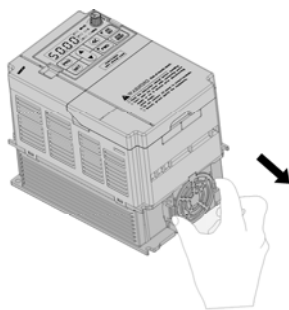

1. Clench the two elastic clips of the fan and pull out and then dismantle the fan cover.

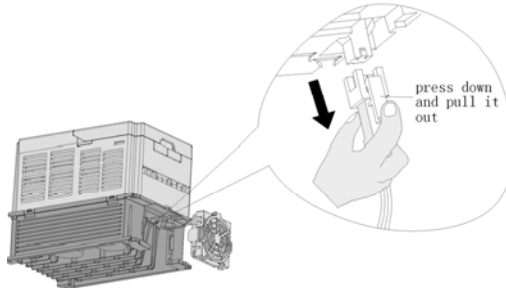

2. Press the elastic clip of the fan toward the inner side and pull out the leading wire terminal of the fan vertically slightly.

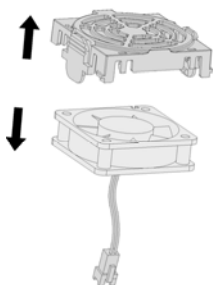

3. Outwardly poke the clips of the fan cover and then separate the fan from the cover slightly.



1. No operation under power connecting state. Otherwise, there is danger of electric shock even death. Before operating, please cut all related equipments power, ensuring that the main circuit DC current has dropped to safe range. And please operate after 5 mins.

2. When the inverter is working, the heat sink temperature would go up due to consumption. To prevent from scalding, please do not touch the heat sink and do not change the fan until the temperature drops into a safe range.

3. To ensure the best performance of the inverter, please use the original fan.



● Other Components

The replacement of the other components has strict requirements on maintenance technical and product familiarity. And they can't be used without strict detection after replacement. So we suggest the user not to replace the other inner components by themselves. If you need to change indeed, please contact the dealer or the sales department of Shenzhen Veichi Electric Co., Ltd.

Chapter 7 Peripherals and Options





7.1 Safety Precautions











In the use of peripherals and options, users shall comply with the following safety precautions and requirements.

	<ul style="list-style-type: none"> ● No operation under power connecting state. Otherwise, there is danger of electric shock. ● Before operating, please cut all related equipments power, ensuring that the main circuit DC current has dropped to safe range. And please operate after 5 mins.
	<ul style="list-style-type: none"> ● No operation when cover/panel is dismantled. Otherwise, there is danger of electric shock. ● Do not dismantle the cover or PCB under power connected state. Otherwise, there is danger of electric shock. ● Only professional personnel can install, debug or maintain the peripherals and options. Otherwise, there is danger. ● Do not wear loose clothes when installing, debugging or maintaining. Rated protective tools and safeguard should be adopted. ● Do not change wire, dismantle jumping wire, optional card, or change cooling fan when the inverter is running. Otherwise, there is danger of electric shock. ● Tighten screw according to specified torque. If main circuit wire connection is loose, there is danger of overheat fire. ● Earth of the peripheral equipments and options must be reliable to prevent human body injury.
	<ul style="list-style-type: none"> ● When operating, please follow the ESD regulations. Otherwise, the inverter may be damaged. ● Do not cut the power supply when the inverter is outputting voltage. Otherwise, the inverter may be damaged.

7.2 Peripherals

Common peripherals are shown in the following table. To order the peripheral equipments, please consult our dealer or sales department.

Peripherals	Functions
	Breaker Protect power system and prevent malfunction impact on other equipments working when short-circuit happens. And over-load protection.
	Residual-current circuit breaker Earth protection from electric shock(suggest to use the type that can prevent high-frequency leakage current)
	Electromagnetic contactor Separate power and inverter and realize basic relay control.
	AC input reactor Improve power side factor and isolate the noise disturbance to the frequency inverter from the power side.

	DC reactor	Restrain ultra-harmonics and improve power factor.
	Input side noise filter	Reduce frequency inverter disturbance to the power and reduce the power grid disturbance.
	Braking resistor	Passive energy consuming unit of electric braking.
	Consumption braking unit	Electric braking control unit, controlling the braking resistance consumption of the regenerated electric power of the motor efficiently.
	Output side noise filter	Reduce the output side wire electromagnetic disturbance.
	Standby system	Standby system for inverter malfunction.
	Heat relay	Protect the motor when overload.
	0-phase reactor	Reduce electromagnetic disturbance of the frequency inverter (suitable for input/output side).
	Main loop surge absorbable unit	Restrain surge voltage when the main loop switch components act.
	Winding surge absorbable unit	Restrain surge voltage when the AC contactor acts.

7.3 The Use of Peripherals

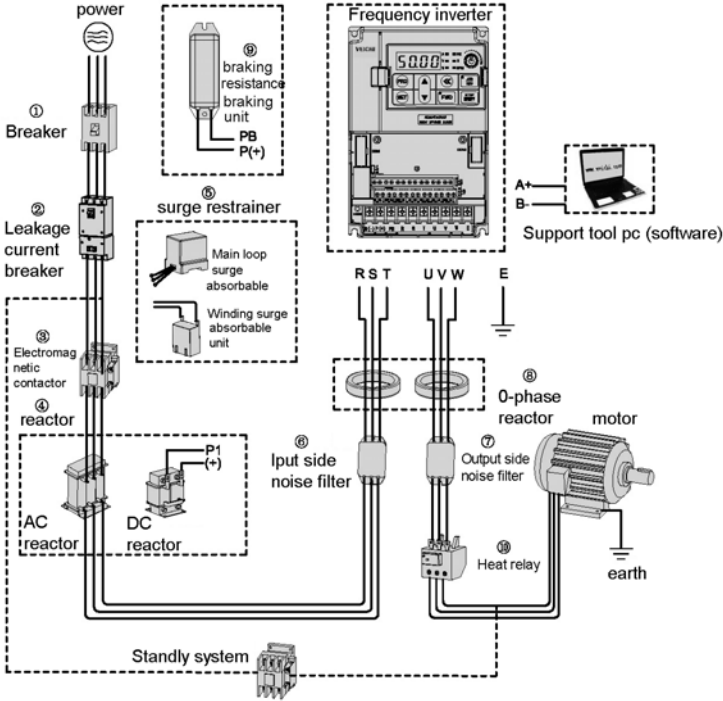

Chart 7-1: Connection of Peripherals

Note:

① Wiring Breaker

To ensure wiring safety and protect power system and prevent malfunction impact on other equipments when short-circuit happens and to ensure over-load protection, please do use wiring breaker between power supply and main loop power input terminals R,S,T.



When choosing the breaker, the capacitance should be about 1.5-2 times of the rated output current of the frequency inverter. Please compare the time characteristic of the breaker and the time characteristic of the inverter protection (150% of the rated output current, 1 minute). Make sure there will be no tripping.



Before the wiring of main loop terminal, make sure that the breaker and electromagnetic contactor are cut. Otherwise, there is danger of electric shock.

② Residual-current Circuit Breaker

The frequency inverter outputs peak voltage high-speed switch square wave, so there is high frequency leakage current. For protection of preventing electric shock and leakage current fire, please install residual current circuit breaker. Usually, one frequency inverter will bring 100mA leakage current (when the power cable length is 1m). If the length prolongs 1m, there will be 5mA more leakage current. So please use residual current circuit breaker specialized for high frequency leakage at the power input side of the frequency inverter. The factors which impact leakage current are as follows:

Capacitance of inverter;

Carrier frequency;

Motor cable type and wire length;

EMI/RFI filter

To protect human body and the inverter, please choose residual current circuit breaker that can use AC/DC power and capable of handling high frequency leakage current. There should be one residual current circuit breaker with more than 200mA sensitive current for every frequency inverter. If the frequency inverter outputs different wave, the high frequency leakage current might be higher due to the difference of the frequency inverter. At this case, please take the following measures:

Improve the sensitive current of the residual current circuit breaker;

Reduce the carrier frequency of the inverter.

③ Electromagnetic Contactor

Electromagnetic contactor is a peripheral set to separate power and inverter connection. When inverter protective function is acting or carrying out emergency stop operation, the main loop power can be cut by peripheral controller. Please do not connect the electromagnetic switch or electromagnetic contactor to the output circuit. Otherwise, the inverter may be damaged. If the power recovers after instant stop, if preventing the inverter from auto-restart is needed, please install electromagnetic contactor for control at the input side.

④ AC Input Reactor and DC Reactor

To restrain current sharp change and high harmonic current, AC input reactor and DC reactor should be used. At the same time the power factor at the input side can also be improved. In the following cases, AC input reactor or DC reactor must be used (use both will bring better effect):

Need to restrain ultra harmonics current and improve power side factor;

Need to switch input phase capacitance;

When frequency inverter is connected to large capacitance power transformer (600kVA above);

Silicon-controlled converters such as DC motor driver are connected to the same power system.

If user has higher requirement on other harmonic restraint, please connect the external DC reactor. Before connecting the external DC reactor, please dismantle the short connector between the terminals P1 and (+).

⑤ Surge Suppressor

Surge suppressor is divided into winding surge suppressor and main loop surge suppressor according to the use position. Please choose the right suppressor on different occasion. The aim of installing surge suppressor is to restrain the surge voltage brought by switch components such as inductive load around the frequency inverter (electromagnetic contactor, electromagnetic relay, electromagnetic valve, electromagnetic winding, electromagnetic detent). Do not connect the surge suppressor to the output side of the frequency inverter. Otherwise, the frequency inverter might be damaged.

⑥ Input Side Noise Filter

Since the rectifier bridge of the inverter is uncontrolled rectifier. And the input current is discontinuous impulse current. The harmonic current noise signal may bring impact on the surrounding machines (radio, phone, noncontact switch, sensor) when it flows to power wire from the inner inverter. At this case, we suggest to install input side noise filter to lighten the noise into the power wire. Besides, it can also reduce noise from the power wire into the frequency inverter.



Please use the specified noise filter for the frequency inverter and the connection wire between the filter and the inverter should be as short as possible.

⑦ Output Side Noise Filter

Since the frequency inverter outputs square wave with high-speed peak voltage switch. So there is high-speed dv/dt convert on the output cables that will produce a lot of radio interference and inductive interference signal. By installing noise filter at the output side, the impact can be relieved. Please do not install static condenser and the noise filter onto the output circuit. Otherwise, there is danger of damage to the inverter.

Ⓢ 0-phase Reactor

0-phase reactor is used for reducing the electromagnetic interference of the inverter, suitable for the input side and output side of the inverter. It's the equal of a three-phase common mode choke. In actual use, according to the actual magnetic core size and cable specification, 3-5 circles winding ratio are recommended to bring the best performance.

Ⓣ Braking Resistor or Braking Unit

Consumption unit of renewable electricity, see Chapter 3, Section 6 "electric installation".

Ⓤ Heat Relay

Please install heat relay at the output side of the frequency inverter. When the motor enters into overload state, the heat relay would cut the power source to protect the motor. When using one frequency inverter to drive one motor, it is unnecessary to install heat relay. The motor overload protection current [FA.20] of the frequency would work as a protection. When using one frequency inverter to drive multiple motors or the motor is driven directly by the power grid, please install heat relay between the inverter and the motor. When installing the heat relay, please design to cut the sequence control circuit of the MC at the main loop input side by the connection spot of the relay or design to input the heat relay action into the frequency inverter as external malfunction. And please pay attention to the following tips to avoid heat relay malfunction and motor overheating at low speed.

Run at low speed:

Multiple motors running in one frequency inverter

Motor cable is very long

Detect malfunction mistakenly because the carrier frequency is too high.

Low Speed and Heat Relay

In normal cases, the heat relay is suitable for universal motor. When using the frequency inverter to run the universal motor (standard motor), the motor current would increase 5-10%, compared with the commercial power supply. Besides, at low speed, even in the motor rated current range, the cooling capability of the fan drove by the motor axis would reduce. And this would lead to motor overheat. So please set the motor overheat protection current [FA.20] of the frequency inverter to be valid.

When Motor Cable Is Long

When the motor cable is long and the carrier frequency is high, impacted by the leakage current, the heat relay may malfunction. To avoid it, please reduce the carrier frequency or set higher detection value of the heat relay. Before increasing the detection value, do confirm if there's any other cause for the motor overheat. Otherwise, there might be danger.

8 Function Parameter Specification

8.1 Basic Parameters

F0.00	Control mode	Setting range: 0-5	Factory default: 1
-------	--------------	--------------------	--------------------

Asynchronous motor control mode (AM):

0: High-performance VC without PG: no speed sensor VC, the control mode is used for all variable speed control. Set the mode when you need high-precision speed control. In this mode control, even without using the feedback signal of the motor, the torque also can respond quickly and get a lot of low-speed torque when the motor is running.

1: VC without PG: Control voltage / frequency ratio, can all shift, especially suitable for occasions of one inverter driving multiple motors, to improve the current shifting system.

The control mode is used for all shift control that does not require fast response and accurate speed control. This mode is also used when motor parameters is not clear or when the motor can't self study.

2: High-performance VC with PG: Speed sensor VC, the control mode is used for all variable speed control that require fast response and high performance torque control. High-precision speed control up to zero speed can be realized. In order to receive the motor speed feedback signal, PG option card is required. Mainly used in places that need high control performance such as high-precision speed control, torque control, simple servo control.

3: VC with PG: Can be used for simple speed feedback control. Please set the mode when needing slow respond but right speed control, especially for occasions when PG feedback does not install on motor spindle, or occasions when motor parameter is not clear or can't self study.

4: VF control: Control by voltage / frequency ratio, can automatically compensate for stator resistance voltage losses, automatic compensation slip frequency, control mode 1 has a higher ratio of low-speed torque and precision, which can be used for low-torque with higher requirements for speed without encoder feedback control.

Synchronous motor control mode (PM):

5: High-performance VC without PG: PMSM PG feedback without VC, real-time observation of motor pole position and speed can be realized by building a complete model and observer of PMSM through software algorithms. This mode requires a complete load identification, suitable for occasions where there're high requirements for acceleration and deceleration time and where the load is the shock load;

6: VC without PG: PMSM PG feedback without VC, and automatically estimate the permanent magnet motor magnetic pole position and the rotor speed through software algorithms and then implement vector control, generally used in occasions where encoders can't be installed and the requirements for starting torque and low frequency performance is not so high, such as air compressors;

7: VC with PG: there's speed sensor control in PMSM with dynamic response and high control performance characteristics, capable of torque control, weak magnetic high-speed operation, and it also can be used for high-power servo control;

Other control modes:

8: Voltage Frequency Output Separately: the output voltage and output frequency can be set and adjusted independently, generally used in fields such as EPS power, torque motor control and high-frequency heating;

Note: 1, PG refers to the speed encoder is used for VC with PG, such as general photoelectric encoder or resolver; matching the corresponding PG card with PG type and parameters are needed; see details in function code [F5.15];

2, When choosing VC mode, before first running, right motor parameters should be inputted and motor parameters self adjust to gain right motor parameter. Please refer to details in F5 parameter groups.

3, Rightly setting VC control parameters to ensure stable and dynamic control performance. For VC

control parameter setting and adjustment, please refer to details of F6 parameter groups.

4. When choosing VC mode, all inverters can only drive one motor, and the capacitance rating difference between the inverters and the motor can't be too large. The inverter can be 2 rating bigger or 1 rating smaller than the motor. Otherwise, the control performance will descend. Or the drive system can't run normally.

F0.01	Speed / torque control mode	Setting range: 0-1	Factory default: 0
-------	-----------------------------	--------------------	--------------------

0: speed control when using speed control, the inverter output command given frequency, and the output torque and load torque is automatically matched, but the output torque is limited by the maximum output torque (see [F6.11]) limits, and when the load torque is greater than the maximum output torque, the inverter output torque is limited, the output frequency and the set frequency would not be the same.

1: Torque Control when using torque control, the inverter output command given torque. At this time, the output frequency and load speed automatic matches, but the output frequency is limited by the torque control forward / reverse maximum speed (see [F7.08, F7.09]). When the load speed is greater than the set maximum speed limit, the inverter output frequency is limited and the output torque would not be the same as the set torque: for torque control specific parameter settings, refer to F7 parameter group.

Note: when the external terminals X1 - X7 input function is selected to "13", the speed and torque would switch by the turning on and off of external terminal, and terminal operation is better than the function code [F0.01]. Torque control is only effective when (F0.00 = 0,2,5,7);

F0.02	Run command channel	Setting range: 0-3	Factory default: 0
-------	---------------------	--------------------	--------------------

It is channel for inverter receiving run and stop order and run direction. It is only used for starting and stopping control under torque control.

0: Keyboard control Inverter run and stop is controlled by keyboard key **FWD, REV/JOG, STOP/RESET, REV/JOG** key is defined as reverse when [F4.02] set as "0" and jog when [F4.02] set as "1". Please refer to details of [F4.02].

1: Terminal control Factory default as two line mode 1 control mode. Under two line mode 1, inverter run, stop and direction is controlled by whether "FWD" or "REV" set for [F2.00-F2.07] "multi function input terminal" connects to control board terminal (COM) or not. "FWD" and "REV" definition refer to [F2.00-F2.07]. When under other control mode, run, stop and direction refer to [F2.12].

2: RS485 communication control Inverter run, stop and direction is controlled by the signal received by RS485 communication terminal. Details refer to Fd communication control parameter group and appendix 2: RS485 communication protocol.

3: Optional card Inverter run, stop and direction is controlled by the signal received by optional card input signal. For the optional card installation, parameter setting and soon, please refer use manual packing with the optional card.

Note: 1. When doing fault reset, key **STOP/RESET**, control terminal reset order and RS485 communication terminal are valid reset order.

2. When inverter input frequency is 0Hz or lower than Min output frequency [F1.26]. As long as you input run order, keyboard FWD indicator will be on, the motor will run as 0 frequency.

Tip: keyboard key **STOP/RESET** function can be selectable. Under exterior terminal control or communication control, it can be defined as stop function. Please refer to [F4.03]. Under exterior terminal control, if use **STOP/RESET** to stop, inverter stops and close exterior terminal run order. It needs to input exterior terminal stop order and unlock. The exterior terminal run order will be valid again. So is the communication control.

F0.03	Frequency give main channel selection	Setting range: 0-12	Factory default: 0
-------	---------------------------------------	---------------------	--------------------

It is used to select frequency given gain channel. The main and assistant channels relationship can be defined by parameter [F0.07].

0: Keyboard Number Setting Given frequency of the main channel is given and modified by [F0.08] keyboard numbers setting frequency. When parameter [F4.04] LED "0" digit "keyboard up/down key modification selection" is set as "1", no matter inverter is run or stop, [F0.08] setting value can be quickly modified by keyboard up/down key directly. Whether store the value modified by the shortcut key is decided by [F4.04] LED "00" digit.

1: Keyboard Potentiometer Given Main channel given frequency is given and modified by keyboard potentiometer. Please refer to [F4.07-F4.10] details for the relationship between keyboard potentiometer and frequency.

2: Terminal VS Voltage Analog Main channel given frequency is given and modified by (VS) input analog. Please refer to [F3.00-F3.04] details for the relationship between input analog filter time and frequency.

3: Terminal AI Analog Main channel given frequency is given and modified by (AI) input analog. Please refer to [F3.05-F3.09] details for the relationship between input analog filter time and frequency.

4: Terminal AS Current Analog Main channel given frequency is given and modified by (AS) input analog. Please refer to [F3.10-F3.14] details for the relationship between input analog filter time and frequency.

5: Terminal Pulse Signal Main channel given frequency is given and modified by (PUL) input pulse signal. Please refer to [F2.16-F2.21] details for the relationship between input pulse signal and frequency.

6: RS485 Communication Port: Main channel given frequency is given and modified by the signal accepted by RS485 communication port (A+) and (B-). Please refer to Fd communication control parameter groups and appendix 2: RS485 communication protocol details.

7: UP/DOWN Control Main channel given frequency is given and modified by if UP terminal is connected to DOWN terminal or not, what is set by multi-function terminals (X1-X8). Anyone of the (X1-X8) terminals can be defined as UP and DOWN. Please refer to [F2.00-F2.07] details. UP, DOWN store and clear mode after adjustment can be set by [F2.22]. Please refer to [F2.22] details. ACC AND DEC of UP/DOWN control running given frequency is set by [F2.23]. UP/DOWN variation frequency can be cleared to 0 at any time by "UP/DOWN clear 0" terminal. Details see [F2.00-F2.07].

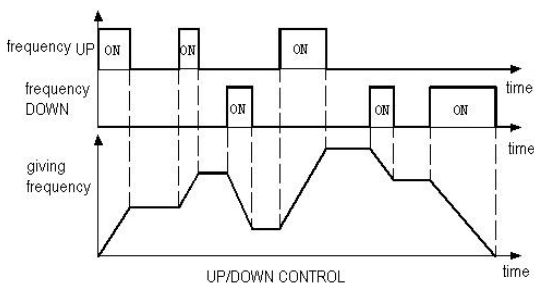

8: PID Control Given: This channel is selected for PID closed loop control system. PID control is the control mode makes feedback the same as the target. Refer to PID control parameters "Fb".

Under this mode, when [F4.04] LED "0" digit is set as 3 by keyboard UP/DOWN key; [Fb.01] can be modified by UP/DOWN key. Whether save the modification is decided by [F4.04] LED "00" digit.

PID control state and trait are changed by multifunction terminals. Details refer to [F2.00-F2.07].

9: Program Control (PLC) Given Main channel given frequency and frequency running direction is controlled by inner simple PLC control. Max 15 steps speed can be process control. Details see "FC" multi step, PLC function and swing frequency parameter group. If one step speed running time is set as "0", it will jump over this step. It is convenient to set

step speed. When [F0.07] LED "00" digit is 0, frequency control direction is invalid. When [F0.16] is set as 2—REV forbid and any step direction is set as REV, this step run as 0 speed. PLC and multi steps speed are both for frequency inverter vary speed and run under certain rules. Under multi steps running, step switch and direction change is control be the different combination between multi step control terminal and COM defined by multifunction input terminals. PLC not only can define one cycle of multi steps frequency in the function parameters. It can also define the run time, direction, ACC/DEC time and cycle mode of multi steps in the function parameters. Multi steps control terminal can be defined by any multifunction terminal. Details refer to [F2.00-F2.07].

10: Optional Card Main channel given frequency is controlled by input signal by optional card. For optional card installation, parameter setting please refers to user manual.

11: VS3 (extended): Select the analog of VS3 expansion card as the frequency command source, and for details please see the expansion card EXIO1 Description.

12: Terminal Switch Frequency setting main channel is selected by frequency selection terminal which can be defined by any multi function terminal. See [F2.00-F2.07] please. Relation table between terminal state and frequency setting channel:

Frequency setting selection terminal 4	Frequency setting selection terminal 3	Frequency setting selection terminal 2	Frequency setting selection terminal 1	Frequency setting channel
OFF	OFF	OFF	OFF	Keyboard number give
OFF	OFF	OFF	ON	Keyboard potentiometer give
OFF	OFF	ON	OFF	Voltage analog VS give
OFF	OFF	ON	ON	Analog AI give
OFF	ON	OFF	OFF	Voltage analog AS give
OFF	ON	OFF	ON	Terminal pulse PUL give
OFF	ON	ON	OFF	RS48 communication give
OFF	ON	ON	ON	UP/DOWN control
ON	OFF	OFF	OFF	PI D control give
ON	OFF	OFF	ON	PLC give
ON	OFF	ON	OFF	Optional card
ON	OFF	ON	ON	VS3 (extended)

Combination details refer to multistep speed time order of "FC" parameter.

Note: valid combination of frequency selection terminal is 0-11(algorithm). Frequency inverter will output 0.00Hz if not within this range. "OFF" in the table means invalid. "ON" means valid.

F0.04	Main channel gain	Setting range: 0.000-5.000	Factory default: 1.000
-------	-------------------	----------------------------	------------------------

It is used to magnify or reduce the main channel input signal, can adjust given frequency of main channel in proportion.

F0.05	Frequency give auxiliary channel selection	Setting range: 0-6	Factory default: 1
-------	--	--------------------	--------------------

It is used to select auxiliary channel for frequency given, directly control or impact output frequency of frequency inverter. Relation between main channel and auxiliary channel can be defined by [F0.07].

0: Keyboard number frequency given

1: Keyboard potentiometer given

2: Terminal VS voltage analog given

3: Terminal AI analog given

4: Terminal AS current analog given

5: Terminal pulse signal given

6: RS485 communication given

The settings of items 0 to 6 are consistent with frequency given main channel selection [F0.03].

F0.06	Auxiliary channel gain	Setting range: 0.000-5.000	Factory default: 1.000
-------	------------------------	----------------------------	------------------------

It is used to magnify or reduce the main channel input signal, can adjust given frequency of main channel in proportion.

F0.07	Frequency give channels combinations mode	Setting range: 0000-0016	Factory default: 0000
-------	---	--------------------------	-----------------------

LED "0" digit: combination mode selection It is used to select the combination method of the main input channel and the auxiliary input channel of the give frequency.

0: Main channel valid: Only main channel [F0.03] is valid, auxiliary channel [F0.05] is invalid.

1: Auxiliary channel valid: Only auxiliary channel [F0.05] is valid, main channel [F0.03] is invalid.

2: Main+auxiliary The sum of main channel [F0.03] add auxiliary channel [F0.05] is the output frequency of the inverter.

3: Main-auxiliary: The result of main channel [F0.03] minus auxiliary channel [F0.05] is the output frequency of the inverter.

4: MAX {main, auxiliary}: The bigger one of main channel [F0.03] and auxiliary channel [F0.05] is the output frequency of the inverter.

5: MIN {main, auxiliary} The smaller one of main channel [F0.03] and auxiliary channel [F0.05] is the output frequency of the inverter.

6: Main*auxiliary Given frequency of main channel [F0.03] multiply certain percent which is percent of given frequency of auxiliary channel [F0.05] responding to max frequency [F0.09]. The result is output frequency of the frequency inverter.

LED "00" digit: frequency control direction selection It is used to select whether permit negative frequency change the running direction of the frequency inverter when the result is negative.

0: invalid If result is negative, frequency inverter output 0.00Hz.

1: valid If result is negative, frequency inverter change running direction and output related frequency.

LED "000" digit: reserved

LED "0000" digit::reserved

Note: 1. When main*auxiliary, frequency only count positive value. When any channel frequency is negative, count as 0.00Hz, frequency inverter output 0.00Hz.

2. Can't overlay main+auxiliary when JOG and multi step speed running.

3. When rotate direction selection [F0.16] is set as REV forbid, whatever frequency control direction selection is set, frequency inverter outputs 0.00Hz frequency if count result is negative.

Tip: Given frequency synthesized by main channel and auxiliary channel also limited by upper limit frequency and lower limit frequency.

F0.08	Keyboard number set frequency	Setting range: 0-upper limitation	Factory default: 50.00Hz
-------	-------------------------------	-----------------------------------	--------------------------

When frequency given channel is keyboard numbers, it is used to set and modify frequency. If [F4.04] LED "0" digit is 1, the up/down key can modify the parameter value. Whether saving the modified value or not after power off is decided by [F4.04] LED "00"digit

F0.09	Max frequency output	Setting range: 0.00-320.00Hz	Factory default: 50.00Hz
F0.10	Upper limitation source selection	Setting range: 0-6	Factory default:0
F0.11	Number give upper limitation	Setting range: Lower limitation-max output frequency	Factory default: 50.00Hz
F0.12	Lower limitation	Setting range: 0.00-upper limitation	Factory default: 0.00Hz
F0.13	Lower limitation run mode	Setting range: 0-1	Factory default: 1

Max frequency output: The max frequency the frequency inverter permit to set. When [F1.13] LED "0" digit is 0, it is also the base of ACC/DEC time setting.

Upper limitation source selection: To select the give source of upper frequency limitation of frequency inverter. It is the max output frequency limitation set according to the machinery max rotate speed.

0: Upper limit number given Upper limitation set by [F0.11]. Max setting is small or equal to max frequency [F0.09]. Min setting is bigger or equal to min frequency [F0.12].

1: Keyboard potentiometer Upper limitation set by keyboard potentiometer.

2: Terminal VS voltage analog Upper limitation set by VS input analog.

3: Terminal AI voltage analog Upper limitation set by AI input analog.

4: Terminal AS current analog Upper limitation set by AS input analog.

5: Terminal pulse PUL given Upper limitation set by PUL input pulse frequency.

6: RS485 communication given Upper limitation set by RS485 communication (0x3004/0x2004). Max set is not over max frequency [F0.09]. Min set not lower than [F0.12]. Details refer to Fd communication control parameter group and appendix 2: Modbus communication protocol, communication given upper frequency (0x3004 / 0x2004).

Note: Relation between input analog or PUL pulse frequency and upper limit frequency: when input max valid value, upper limit frequency is max frequency [F0.09]. When input min valid value, upper limit frequency is 0.00Hz.

Number setting of upper limitation: It is the upper limit frequency given channel when [F0.10] is set as 0.

Lower limitation: It is the lower limitation of output frequency. When given frequency is lower than this value, [F0.13] decides the run frequency.

Lower limitation run mode

0: Stop: When actual given frequency is lower than the lower limitation, inverter runs at 0.00Hz.

1: Run as lower limitation: When actual given frequency is lower than the lower limitation, inverter run at the lower limitation.

Note: 1. Given upper limitation by analog or PUL pulse frequency, lower limitation is invalid if upper limitation is lower than lower limitation.

2. Max frequency, upper limitation and lower limitation set carefully according to actual need please. Except upper limitation and lower limitation, inverter is also limited by parameters set such as start frequency, free stop frequency, stop DC brake start frequency and so on. Max frequency, upper limitation and lower limitation relationship as below:

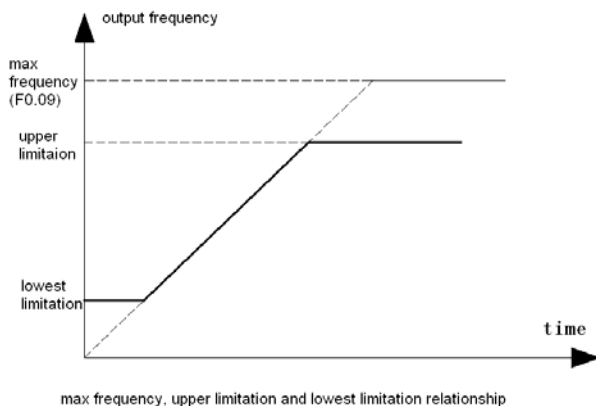

F0.14	ACC time 1	Setting range: 0.01-650.00s	Factory default: model set
F0.15	DEC time 1	Setting range: 0.01-650.00s	Factory default: model set

ACC time 1: When [F1.13] LED "0" digit is 0, it means the time needed for output frequency accelerate from 0.00Hz to max frequency [F0.09]. When [F1.13] LED "0" digit is 1, it means the time needed for output frequency accelerate from 0.00Hz to 50.00Hz. Details refer to [F1.13].

DEC time 1: When [F1.13] LED "0" digit is 0, it means the time needed for output frequency decelerate from max frequency [F0.09] to 0.00Hz. When [F1.13] LED "0" digit is 1, it means the time needed for output frequency decelerate from 50Hz to 0.00Hz. Details refer to [F1.13].

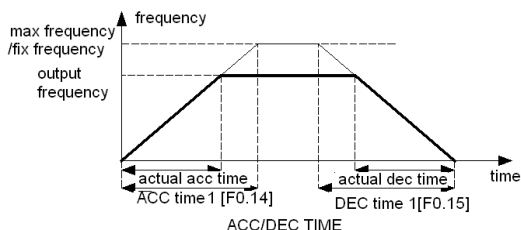

This frequency inverter can set 4 kinds of ACC/DEC time at most. If there's need to select other ACC/DEC time group, it must be selected by control terminal. For details please refer to [F2.00-F2.07] and [F1.18-F1.23].

ACC time is only valid for normal speed-up process, not including start per-excite, start DC brake time and start frequency hold time. DEC time is only valid for normal speed process, not including stop DC brake time.

During process running, ACC/DEC time 1 is defined as first kind of ACC/DEC time. The other 3 kinds of ACC/DEC time details please refer to [F1.18-F1.23].

JOG ACC/DEC time is set by [F1.33, F1.34] alone.

F0.16	Rotate direction choosing	Setting range: 0-2	Factory default: 0
-------	---------------------------	--------------------	--------------------

0: Consistent: The actual run direction is the same as required. No adjustment to the current direction.

1: Reverse: The actual run direction is reverse to the required direction. Adjust the current direction.

2: Forbid reverse: When it is set as forbid, the reverse orders of all run order channels (operation board, exterior

terminal, RS485 communication, optional card and program running) are invalid.

When frequency setting is negative (including that after combination), no matter what the [F0.07] LED "00" digit is, the actual output frequency is limited as 0.00Hz.

Note: When reset to factory default, this setting is not changed.

Attention: All reverse order is forbidden. If reverse order is give, the frequency inverter would not run.

F0.17	Carrier frequency	Setting range: 0.6-15.0KHz	Factory default: Accord model
-------	-------------------	----------------------------	-------------------------------

It is used to set IGBT frequency. Please set this parameter when adjusting electromagnetic noise and reducing leakage current. This feature is mainly used to improve noise and vibration during operation of the inverter. At higher carrier frequency of the current wave, the motor noise would be small. It is suitable for locations that need mute environment when run in high carrier frequency, but at the same time the main parts switch loss and the heat are heavy while the efficiency would be reduced. In the meantime, radio disturbance is heavy. And the other problem is that capacitance leak current would increase, and if there is leak protection, there may be mistake action or over current. When run in low carrier frequency, the case will be totally different. Different motors would have different carrier frequency responses. The best carrier frequency comes with adjustment based on actual case. The bigger the capacity, the smaller the carrier frequency should be.

The Company reserves the right to limit maximum carrier frequency.

Carrier frequency	Motor noise	Electric disturbance	Radiator temperature
low	big	Small	low
↓	↓	↓	↓
high	small	big	high

Note: We advice ratio of carrier frequency to max frequency not lower than 36. If work under low frequency long time, we advice reduce carrier frequency to reduce the dead area time impact.

Attention: when carrier frequency is higher than the factory default, the rated power would reduce 5% every time when carrier frequency adds 1 KHz.

F0.18	Carrier PWM frequency characteristic selection	Setting range: 0000-3111	Factory default: 0010
-------	--	--------------------------	-----------------------

LED "0" digit: carrier temperature associated settings

0: associated module temperature is invalid

1: associated module temperature is valid

When module temperature is too high, the frequency inverter reduces carrier frequency automatically, which can reduce switch loss and avoid frequent alarm for over heat.

LED "00" digit: associated settings of carrier output frequency

0: associated frequency output temperature is invalid

1: associated frequency output temperature is valid

When carrier frequency is related to frequency output, it can automatic adjust carrier frequency according to frequency output, which can improve the low frequency performance and high frequency mute effect.

LED "000" digit: random PWM switch

0: Fixed carrier: Noise frequency is fixed.

1: **Random carrier:** This mode allows the inverter output voltage harmonic spectrum evenly distributes over a wide frequency range, which can effectively suppress electrical noise and mechanical vibration.

LED "0000": over modulation mode

0: close: close the PWM

1: start: start the PWM

Starting over modulation can improve the maximum output voltage, in the case of low grid voltage and high frequency, starting over modulation can reduce the motor current.

F0.19	Parameter initialization	Setting range: 0-3	Factory default: 0
-------	--------------------------	--------------------	--------------------

0: No operation

1: Restore factory default, function parameters are restored to factory defaults, excluding motor parameter group.

2: Clear malfunction records, clear all [FA.25-FA.44] mistake history.

3: Restore factory default, after restoring to factory defaults, the motor parameters are all restored.

Note:

1: Keyboard shows SRVE when recover factory setting. SRVE disappear when initialization finished.

2: No changing of [F0.16] and [F4.11-F4.14] setting when recovering factory setting.

3: If power off when recovering factory defaults, it can't be completed. It needs to restore after power on again.

4: In the parameter initialization, the keyboard will display "SAVE", and the initialization is over when "SAVE" jump to the parameter interface. If power stops suddenly during the display "SAVE", the inverter will initialize all system parameters, which would affect the using of it.

F0.20	AVR function selection	Setting range: 0-1	Factory default: 1
-------	------------------------	--------------------	--------------------

Starting modulation can improve the extreme value of the output voltage in a certain degree; when the motor reaches the rated speed and when the load is heavy, over-modulation could reduce output current by increasing the output voltage.

0: over-modulation turns off

1: over-modulation turns on

F0.21-F0.23	Reserved		
-------------	----------	--	--

F0.24	Running command bundling	Setting range: 0000-0AAA	Factory default:0000
-------	--------------------------	--------------------------	----------------------

When this parameter is effective, it can be used for the settings on each run command channel bundling frequency source channel. When the command source has bundled frequency source, during the valid period of this command, frequency from [F0.03-F0.06] and [F0.07] LED bit combinations will no longer be valid, but [F0.07] LED tens frequency directional control is still valid.

0: No bundled: Press [F0.03]-[F0.06] and [F0.07] LED bit combination set to determine the frequency given.

1: Keyboard number frequency given

2: Keyboard potentiometer given

3: Terminal VS voltage analog given

4: Terminal AI analog given

5: Terminal AS current analog given

6: Terminal pulse signal given

7: RS485 communication given

8: Terminal UP/DW control

9: PID control given

10: Procedure control PLC given

11: Optional card

12: VS3 (extended)

The settings of items 0 to 10 are consistent with frequency given main channel selection [F0.03].

F0.25	Reserved		
-------	----------	--	--

F0.26	Pressure frequency separation output voltage source	Setting range: 0-8	Factory default: 0
-------	---	--------------------	--------------------

When [F0.00] = 8 (voltage-frequency separate output mode), the function code command to set the output voltage source;

0: function code F0.27 setting: voltage is set directly by [F0.27];

1: voltage analog VS given: voltage is given by the voltage analog input terminal;

2: The voltage / current analog AI given: voltage is given by the voltage or current analog input terminal;

3: The current analog AS given: voltage is given by the current analog input;

4: Terminal pulse PUL given: voltage is given by the terminal pulse;

5: PID control given: voltage is determined by PID operation, see in PID introduction in FB group;

6: RS485 communication given: voltage is given by the RS485 communication; mailing address 0x300A / 0x200A;

When voltage and frequency separately output, the output voltage command is 100.0% corresponding to the rated motor voltage [F5.05] while the output frequency command is designated by the main and auxiliary frequency source.

Please see in [F0.03], [F0.05], [F0.07]

F0.27	Pressure frequency separation output voltage value setting	Setting range: 0.0%-100.0%	Factory default: 0
F0.28	Pressure frequency separation output voltage increasing period	Setting range: 0.0-1000.0s	Factory default: 1.0
F0.29	Pressure frequency separation output voltage decreasing period	Setting range: 0.01-000.0s	Factory default: 1.0

Pressure frequency separation output voltage value setting: When [F0.26] = 0, voltage source is given by the parameter; set 100% corresponding rated voltage value.

Pressure frequency separation output voltage increasing period: time required for the motor voltage output from zero to the rated voltage.

Pressure frequency separation output voltage decreasing period: time required for the motor voltage output from rated voltage too.

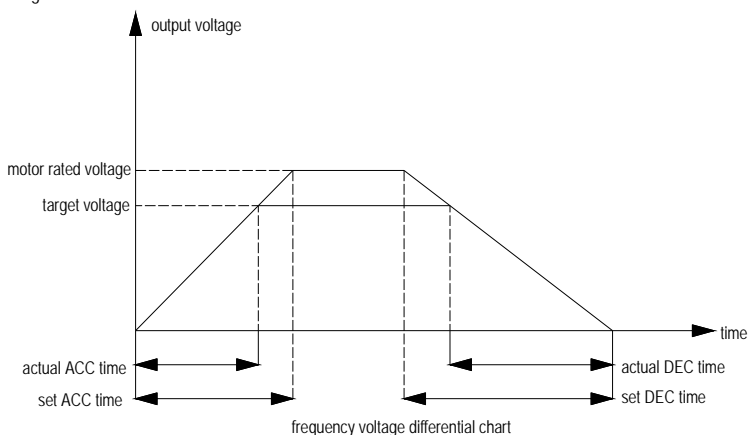

F0.30	Pressure frequency separation output voltage stop mode	Setting range: 0.01-000.0s	Factory default: 1.0
-------	--	----------------------------	----------------------

Pressure frequency separation output voltage stop mode of the function code:

0: voltage / frequency decreases to 0 at the same time.

1: frequency decreases after voltage drops to zero.

8.2 Running Control Parameter

F1.00	Start-up mode	Setting range: 0-2	Factory default: 0
F1.01	Start pre-excitation time	Setting range: 0.00-60.00s	Factory default: mode setting
F1.02	Start frequency	Setting range: 0.00-60.00Hz	Factory default: 0.50Hz
F1.03	Start frequency hold time	Setting range: 0.0-50.0s	Factory default: 0.0s
F1.04	Braking current before start	Setting range: 0.0-150.0%	Factory default: 0.0%
F1.05	Braking time before start	Setting range: 0.0-60.0s	Factory default: 0.0s

Start-up Mode

0: Start by start-up frequency [F1.02] start-up frequency and **[F1.03]** start-up frequency hold time control the frequency inverter start. It is suitable for big static friction torque and small load inertia occasion or occasion with exterior machine brake equipment. Motor spindle can keep static before restart after stop.

1: DC brake and start. Firstly [F1.04] brake current and **[F1.05]** brake time give certain energy to motor with load (electromagnetic hold brake). Then start by start-up frequency. It is suitable for stop state, small inertia load with REV and FWD.

2: Speed track, direction judge and start Detect speed and direction firstly, and then start as the speed detected out and reach the given frequency according to ACC/DEC time. Speed tracking modes include inner speed tracking and external speed tracking, selected by the transfer terminal.

Control mode / Tracking mode	VC without PG	V/F without PG	VC with PG(PG card input)	VC with PG(PUL input)	V/F with PG (PG card input)	V/F with PG(PUL input)
Internal tracking	Valid	Valid		Valid		Valid
External tracking			Valid		Valid	

Start pre-excitation time: It is used to set pre-excitation time for asynchrony motor when start. It can set up magnetic field before motor start and improve start performance and reduce start current and start time.

Start frequency: It is the initial output frequency when start. Right start frequency can bring big start torque. When start, certain instant force can be brought for load with big static friction under static state. But if the set value is too large, sometimes there might be fault like E.oC1.

Start frequency hold time: the time of the inverter running under start frequency.

Braking current before start: It is the braking current that the inverter gives the motor when DC braking. It is based on the output rated current of the inverter. Only when **[F1.00]** is 1, there would be DC braking when start. When the parameter is set to 0, the DC braking is invalid.

Braking time before start: It is the time that DC braking current hold when start. Only when **[F1.00]** is 1, there is DC braking when start. There is no DC braking when braking time is 0.0s.

Note: Start frequency is not limited by lower limit frequency [F0.12], but limited by [F1.26] min output frequency.

If setting is smaller than [F1.26], the output frequency is 0.00Hz.

Reminder: 1: Under process of REV/FWD switch when normal running or process of frequency setting change when up/down running, frequency inverter starts from or reduces to min output frequency [F1.26] and then output 0.00Hz.

2: In process of inverter start ACC, inverter output 0 when given frequency is small than start frequency.

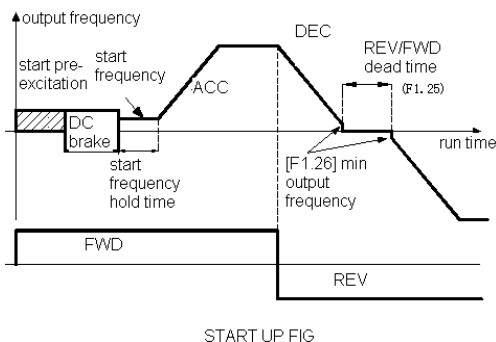

F1.06	Speed track waiting time	Setting range: 0.00-60.00s	Factory default model setting
-------	--------------------------	----------------------------	-------------------------------

It is defined as the waiting time from inverter receiving the run order to the time inverter starts speed tracking. After this time, inverter output according to the frequency and direction detected and running to given frequency according to the ACC/DEC time setting.

For big inertia load, prolong speed track waiting time to reduce the instant impact current.

F1.07	Stop mode	Setting range: 0-1	Factory default: 0
-------	-----------	--------------------	--------------------

0: DEC to stop DEC to 0.00Hz and stop output. When give frequency is small then stop DC braking start frequent [F1.08], inverter output frequency will change to 0. DC brake and stop work. Otherwise inverter will decelerate to min output frequency and stop working.

For inverter with build in braking unit (under than AC100-T3-018G), braking resistor (optional) can be used. When DC bus voltage is over [FA.08] energy braking act voltage, inverter begins to carry out the energy braking act.

For inverter without build in braking unit (upper than AC100-T3-022G), braking unit and braking resistance can be selected. It is mainly used for occasions that need quick braking when stop.

1: Free stop Inverter stop output when receiving the stop order. Usually, it cooperates with exterior machine hold brake.

F1.08	Initial frequency of stop DC braking	Setting range: 0.00-50.00Hz	Factory default: 0.00Hz
F1.09	Stop DC braking current	Setting range: 0.0-150.0%	Factory default: 0.0%
F1.10	Waiting time of stop DC braking	Setting range: 0.0-60.0s	Factory default: 0.0s
F1.11	Stop DC braking duration	Setting range: 0.0-60.0s	Factory default: 0.0s

Initial frequency of stop DC braking: When inverter DEC to this frequency, it will stop output and start DC braking. In stop state, when the output frequency is less than shutdown DC braking starting frequency, the DC brake function

would start.

During deceleration, when a given frequency is less than shutdown DC braking start frequency, start DC braking and the output frequency will jump to zero. If there's no strict requirement for operating conditions, the DC brake start frequency should be set as low as possible

Stop DC braking current: It is the current that inverter give motor when DC braking. It is based on the output rated current of the inverter. DC braking can afford 0 speed torque. It is usually used for improve stop accuracy and quick stop. It can't be used for DEC braking for normal running.

Waiting time of stop DC braking: It is the time for waiting to DC braking when inverter DEC to initial frequency of stop DC braking and stop output.

Stop DC braking duration: It is DC braking current holding time after stop. It is no DC braking process when braking time is 0.0s.

F1.12	Reserved
-------	----------

F1.13	ACC/DEC mode selections	Setting range: 0000-0011	Factory default: 0000
F1.14	Start ACC rate of S curve	Setting range: 20.0%-100.0%	Factory default: 50.0%
F1.15	Start DEC rate of S curve	Setting range: 20.0%-100.0%	Factory default: 50.0%

ACC/DEC mode selections

LED "0" digit: ACC/DEC time base

0: max frequency Base is max frequency [F0.09]

1: fixed frequency Base is 50.00Hz

LED "00" digit: ACC/DEC mode

0: straight line Suitable for general load.

1: S Curve Suitable for load need reduce noise, vibration, impact or load need descend torque for low frequency and ACC short time for high frequency. If over current or over load when start, please increase [F1.14] setting.

LED "000" digit: reserved

LED "0000" digit: reserved

Start ACC rate of S curve: It is the rate when start ACC. The smaller the rate is, the ACC S curve is sharper.

Otherwise, the bigger the rate is, the ACC S curve is more like a beeline. If you want it ACC more smoothly, you can reduce the rate and prolong ACC time.

Start DEC rate of S curve: It is the rate when start DEC. The smaller the rate is, the DEC S curve is sharper.

Otherwise, the bigger the rate is, the ACC S curve is more like a beeline. If you want it DEC more smoothly, you can reduce the rate and prolong DEC time.

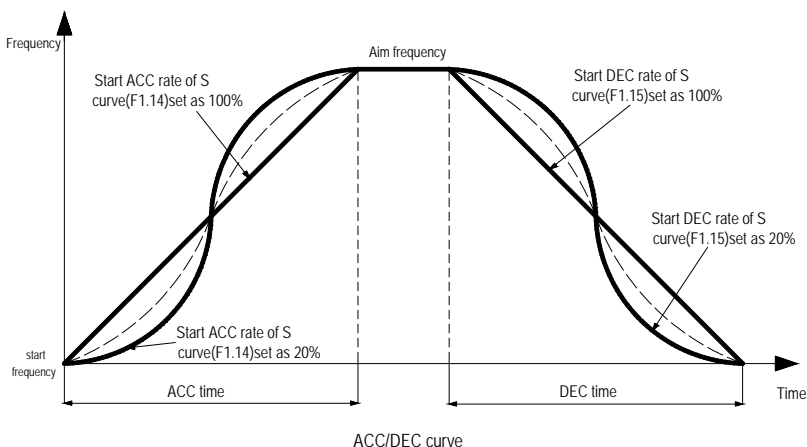

Note: ACC /DEC time will not be changed when modifying F1.14 and F1.15.

F1.16-F1.17	Reserved
-------------	----------

F1.18	ACC time 2	Setting range: 0.01-650.00s	Factory default: 10.00s
F1.19	DEC time 2	Setting range: 0.01-650.00s	Factory default: 10.00s
F1.20	ACC time 3	Setting range: 0.01-650.00s	Factory default: 10.00s
F1.21	DEC time 3	Setting range: 0.01-650.00s	Factory default: 10.00s
F1.22	ACC time 4	Setting range: 0.01-650.00s	Factory default: 10.00s
F1.23	DEC time 4	Setting range: 0.01-650.00s	Factory default: 10.00s

ACC time 2/3/4: When [F1.13] LED "0" digit is 0, it means the time need for output frequency ACC from 0.00Hz to max frequency [F0.09]. When [F1.13] LED "0" digit is 1, it means the time need for output frequency ACC from 0.00Hz to 50.00Hz. Details refer to [F1.13].

DEC time 2/3/4: When [F1.13] LED "0" digit is 0, it means the time need for output frequency DEC from max frequency [F0.09] to 0.00Hz. When [F1.13] LED "0" digit is 1, it means the time need for output frequency DEC from 50.00Hz to 0.00Hz.

ACC/DEC time 2/3/4 can only be determined by the on-off combination of multi-functional terminals such as 'deceleration time selection terminal 1' and 'deceleration time selection terminal 2' and (COM) to switch the current ACC/DEC time group (except PLC program running);

If the ACC/DEC time selection terminal has not been set, the default deceleration time 1 is valid and the inverter would implement ACC/DEC according to the ACC/DEC 1.

ACC/DEC time details refer to [FC.31-FC.45].

JOG ACC/DEC time is set by [F1.33, F1.34]

ACC/DEC time table:

Terminal 2	Terminal 1	ACC/DEC time selection
OFF	OFF	ACC/DEC time 1
OFF	ON	ACC/DEC time 2
ON	OFF	ACC/DEC time 3
ON	ON	ACC/DEC time 4

If any unclear, please see FC parameter group multi steps time order fig.

F1.24	Emergency stop DEC time	Setting range: 0.01-650.00s	Factory default: 10.00s
-------	-------------------------	-----------------------------	-------------------------

Used to set the DEC time of emergency stop; it is the same as the definition of ACC/DEC time.

Emergency stop can be take effect by emergency stop terminal; details refer to [F2.00-F2.07]. When terminal control two line run, whether carry out the original run order is decided by [F2.13] LED *00* digit. Details refer to [F2.13]. When multifunction terminal is set as emergency stop, refer to detail [F2.29-F2.31].

F1.25	FWD&REV dead area time	Setting range: 0.0-120.0s	Factory default: 0.0s
F1.26	Min output frequency	Setting range: 0.00-60.00Hz	Factory default: 0.50Hz

FWD&REV dead area time: Waiting time at 0.0Hz when switch between FWD/REV. It sets for equipment with machine dead area when big inertia load and change direction.

Note: [F1.25] is valid only for the FWD&REV dead area of the speed control mode, the FWD&REV dead area of torque control mode is determined by [F7.12].

Min output frequency: If lower than this frequency, inverter output 0.00Hz

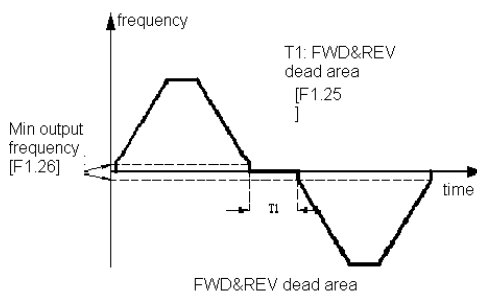

F1.27	0 speed hold torque	Setting range: 0.0-150.0%	Factory default: model setting
-------	---------------------	---------------------------	--------------------------------

Set output torque at 0 speed. If the torque setting is too big or the duration is too long during the time of use, the cooling of motors should be noticed.

F1.28	0 speed hold torque time	Setting range:0.0-6000.0s	Factory default: 0.0s
-------	--------------------------	---------------------------	-----------------------

Set output torque keep time at 0 speed. Count from 0Hz, stop output when arriving this set time. Valid count value range is 0-5999.9s. Frequency inverter counts as setting when it is within valid range and stop 0 speed hold torque when time finished.

If set as 6000.0s, frequency inverter will not count, default as 0 speed hold torque always valid and only stop when stop or give running frequency not 0.

Suitable 0 speed hold torque time setting can save energy effectively and protect motor.

Note: 0 speed torque hold is only valid when F0.00=0, F0.00=1orF0.00=4;Please pay attention to motor temperature rise when 0 speed hold torque time is too long or 0 speed hold torque is too big. If temperature rises too high, it needs add equipment to improve motor radiation.

F1.29	Power off restart action selection	Setting range: 0-1	Factory default: 0
F1.30	Power off restart waiting time	Setting range: 0.00-120.00s	Factory default: 0.50s

Power off restart action selection:

0: Invalid: Only run with order for power on again. When keyboard operation control, RS485 communication control or optional card control is working, the running order would be automatically cleared when power off.

When external terminal control, run as [F1.31] setting.

1: Valid If inverter is at run state before power off, it start automatically after [F1.30] waiting time. When waiting, it does not accept any orders. But if inputting stop order, it will not restart.

Note: Power off restart action selection can make machine automatic re-start when power recovers. Please use it carefully.

Power off restart waiting time: When [F1.29] setting is valid, inverter restarts after [F1.30] waiting time. The setting principle of the time is mainly based on the related recovery preparation time after power restoration.

F1.31	Terminal running protection selection	Setting range :0000-0011	Factory default: 11
-------	---------------------------------------	--------------------------	---------------------

After selecting terminal operation, the initial state of the peripheral device wiring may affect the device safety, which would provide protective measures for terminal operation.

LED "0" digit: when electrifying, terminal operation command selection

Implement operation command when electrifying and when the terminal operation command is valid.

0: Terminal running order invalid: when electrifying terminal controls stop firstly and then restart.

1: Terminal running order valid: when electrifying terminal controls start directly

LED "00" digit: when switch the running order give channel

Select running order channel switching to terminal order when the terminal operation command is valid; Implement operation command method

0: invalid Terminal controls stop firstly and then restart.

1: valid Terminal controls start directly.

F1.32	JOG running frequency setting	Setting range: 0.00-Max frequency	Factory default: 5.00Hz
F1.33	JOG ACC time	Setting range: 0.01-650.00s	Factory default: 10.00s
F1.34	JOG DEC time	Setting range: 0.01-650.00s	Factory default: 10.00s

JOG running frequency setting: Set output frequency when JOG.

JOG ACC time: When [F1.13] LED*0"digit is 0, it means the time need for output frequency ACC from 0.00Hz to max frequency [F0.09]. When [F1.13] LED*0"digit is 1, it means the time need for output frequency ACC from 0.00Hz to 50.00Hz. Details see [F1.13].

JOG DEC time: When [F1.13] LED "0"digit is 0, it means the time need for output frequency DEC from max frequency [F0.09] to 0.00Hz. When [F1.13] LED "0"digit is 1, it means the time need for output frequency DEC from 50.00Hz to 0.00Hz.

Note: JOG run frequency set is only limited by [F0.09]. When JOG frequency setting is bigger than [F0.11] upper limitation, actual JOG output frequency is limited by upper limitation. Only terminal JOG priority is not limited by run order channels. Other JOG orders have priority only when the channel is the same as others. Such as keyboard JOG is only valid under keyboard control.

F1.35	Jump frequency	Setting range: 0.00-Max frequency	Factory default: 0.00Hz
F1.36	Jump frequency range	Setting range: 0.00-Max frequency	Factory default: 0.00Hz

Jump frequency: When running, the frequency avoid running.

Jump frequency range: The up/down frequency range of [F1.35] avoid running.

When the inverter is running with load, in order to avoid resonance frequencies of mechanical load for the output frequency, jump frequency can be used to avoid the resonance. The inverter can set one jump point to implement the jumping and after setting the skip frequency parameters, even if the drive frequency is within the given point of the mechanical resonance frequency of the load, the output frequency of the inverter will be automatically adjusted to the resonance frequencies of the external mechanical load in order to avoid running on the resonance point.

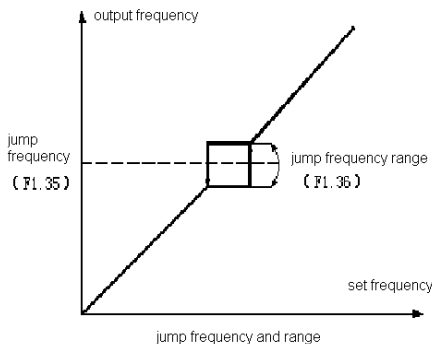

Note: Output frequency will jump through frequency area when ACC/DEC.

8.3 Quantum Digital Terminal Parameter

F2.00	Multifunction input terminal 1(X1)	Setting range: 0-47	Factory default:1
F2.01	Multifunction input terminal 2(X2)		Factory default:2
F2.02	Multifunction input terminal 3(X3)		Factory default:4
F2.03	Multifunction input terminal 4(X4)		Factory default:5
F2.04	Multifunction input terminal 5(X5)		Factory default:6
F2.05	Multifunction input terminal 6(X6)		Factory default:8
F2.06	Multifunction input terminal 7(X7)		Factory default:10

There're seven multifunction terminals(X1-X7) which can be defined by [F2.00-F2.06]. the feature and filter time can be defined by [F2.08-F2.11].

X7 is sharing an external input terminal X7 / PUL with the high-speed pulse input; when there is a timing function code selection PUL given, the PUL input as external terminals, otherwise input as X7 input. For example, when [F0.03] = 5, the terminal X7 / PUL would be valid as PUL input, and the switch signal input X7 would not be accepted.

Note: the seven multi-function input terminals actually exist, in order to avoid the repetition of the input terminal selection function, the actual setting will be against each other; for example, when [F2.00] = 1, the F2.01 can't be set as 1 and it can only be set as any other value that is not within [F2.00] , [F2.02 ~ F2.06] and [F2.69 ~ F2.71].

Multi-function input terminals can be easily set and chosen according to needs. Settings and functions in the table below:

Setting	Setting	Setting	Setting
0	No function(can choose again)	24	PID trait switch
1	FWD	25	PID give switch 1
2	REV	26	PID give switch 2
3	3 line running control(Xi)	27	PID give switch 3
4	FWD JOG	28	PID feedback switch 1
5	REV JOG	29	PID feedback switch 2
6	Free stop	30	PID feedback switch 3
7	Emergency stop	31	PLC pause
8	Fault reset	32	PLC restart
9	Out fault input	33	Swing frequency input
10	Frequency (UP)	34	Swing frequency pause
11	Frequency (DW)	35	Swing frequency reset
12	(UP/DW clear)	36	Frequency channel switch terminal 1
13	Reserved	37	Frequency channel switch terminal 2
14	Reserved	38	Frequency channel switch terminal 3
15	Multi speed terminal 1	39	Frequency channel switch terminal 4
16	Multi speed terminal 2	40	Timer touch terminal
17	Multi speed terminal 3	41	Timer clear terminal
18	Multi speed terminal 4	42	Counter clock input terminal
19	ACC/DEC time selection terminal 1	43	Counter clear terminal
20	ACC/DEC time selection terminal 2	44	DC brake order
21	ACC/DEC pause	45	Pre-excitation order terminal
22	PID control cancel	46	Reserved
23	PID control pause	47	Reserved

0: No function: it means terminal invalid. If the terminal function is idle, it is recommended to set "0" to prevent the occurrence of misuse.

1: FWD When run order is given by terminal, and [F2.12] is set as 2 line 1, and when the terminal is valid, inverter will FWD. Other control mode, please refer to [F2.12].

2: REV When run order is given by terminal, and [F2.12] is set as 2 line 1, and when the terminal is valid, inverter will REV. Other control mode, please refer to [F2.12].

3: 3 line run control (Xi): When the run order is given by terminal, and [F2.12] is set as 3 line 1/2, it is 3 line run control (Xi). Details refer to [F2.12].

4: FWD JOG

5: REV JOG

When the terminal is valid, the inverter jogs forward. Terminal jog command has the highest priority. Jog parameters detailed settings see [F1.32-F1.34].

6: Free stop: When it is valid, inverter stops output. Motor will free run. When free stop terminal is always valid, inverter does not accept any start order and keep stop state. Whether recover to original order after free stop order is relieved when terminal 2 line control running, refer to [F2.13] please. It does not recover to original order after free stop order is relieved when keyboard, RS485, optional card and terminal 3 line control running. If need start inverter, it needs to input run order again.

7: Emergency stop If input emergency stop order when running, inverter DEC and stop according [F1.24] DEC time

setting. Details refer to [F1.24]. It can't run again before totally stopping. When [F1.07] is set as free stop, emergency stop order and free stop order is same function. Once this terminal is valid, inverter stops output and free stop immediately. If emergency stop terminal is always valid, inverter does not accept start order and keep stop. Under 2 line control mode, whether recover original run order after relieve emergency stop order is decided by [F2.13]. When working under keyboard, RS485, optional card and terminal 3 line control mode, the original order would not be recovered when the emergency stop order is removed. If need start inverter, please input order again.

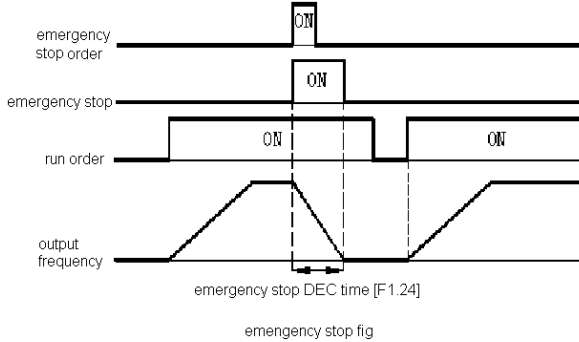

Note: When use emergency stop function, please set right [F1.24] DEC time or work with energy brake function.

Otherwise over-voltage fault might happen. Therefore, when using the emergency stop function, please set appropriate deceleration time under [F1.24], or cooperate with the use of dynamic braking function.

8: Fault reset: The inverter can be reset by the terminal when alarm. Whether recover original order after fault reset is decided by [F2.13].

9: Out fault input Inverter stop output when accept external fault input signal by it, which is convenient for the fault monitoring and protection of external equipments. Output would be sealed when receiving external input signal and motor runs freely and displays fault information E.EF.

10: Frequency (UP)

11: Frequency (DW)

Frequency UP/DW is realized by the control terminal. And the control would be valid only when [F0.03] is set as 7. Details refer to [F0.03].

12: (UP/DW clear): Only valid when [F0.03] is set as 7. Details refer to [F0.03].

13: Speed torque control switching

Terminal switching priority over [F0.01], torque control when effective: determined by [F0.01] setting when invalid

Terminal	Control mode
OFF	F0.01 = 0 speed mode
	F0.01 = 1 torque mode
ON	Torque mode

14: Torque control forbidden

Speed control when effective, not impacted by [F0.01] and terminal operation "speed torque control switching", when terminal "Torque control prohibition" is invalid the function code [F0.01] would decide the setting.

Terminal	Control mode
OFF	Set by F0.01
ON	Speed mode

15: Multi steps terminal 1

16: Multi steps terminal 2

17: Multi steps terminal 3**18: Multi steps terminal 4**

15 speeds would be realized by code combinations for multi-speed instruction; multi-speed command has priority second only to jog command. See parameter details of multi steps and FC group of PLC.

19: ACC/DEC time selection terminal 1**20: ACC/DEC time selection terminal 2**

4 ACC/DEC speeds would be realized by code combinations. ACC/DEC time selection terminal 1 is defaulted as valid when not set parameter and terminal invalid. Details see [F1.18-F1.23].

21: ACC/DEC pause: In ACC/DEC process, if the terminal is valid, the inverter stops ACC/DEC and keeps the speed. It is only valid when inverter is running. It is invalid for DEC stop.

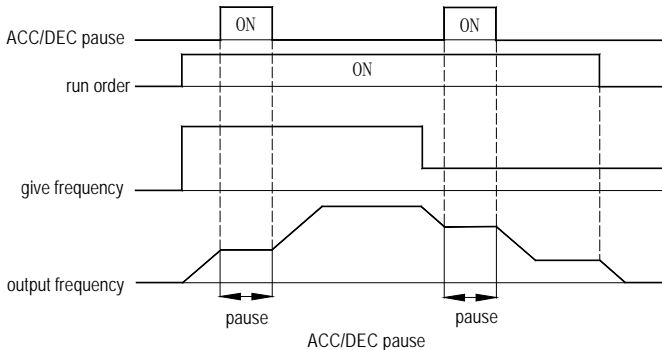

22: PID control cancel: When [F0.03] is set as 8 and this terminal is valid, it can make PID function invalid; when the given frequency of main frequency channel is changed to 0.00Hz. And when this terminal is invalid, the PID re-counts the given frequency of main channel.

23: PID control pause: When PID given and this terminal is valid, it can make PID adjustment be invalid and keep frequency not change. PID re-counts the given frequency of main channel.

24: PID trait switch When [F0.03] is set as 8 and this terminal is valid, [Fb.05] LED "0" digit-trait setting will be changed. PID output trait back to [Fb.05] LED "0" digit-trait setting.

25: PID given switch 1**26: PID given switch 2****27: PID given switch 3**

When PID controller given signal source [Fb.00] is set as 8, give signal source channel can be switched by this group of terminals. Details see [Fb.00].

28: PID feedback switch 1**29: PID feedback switch 2****30: PID feedback switch 3**

When PID controller feedback signal source [Fb.02] is set as 8, feedback signal source channel can be switched by this group of terminals. Details refer to [Fb.02].

31: PLC pause: When [F0.03] is 9, this valid signal can make PLC pause and inverter output 0.00Hz. Inverter goes on as before when this signal disappears. See parameter details of multi steps and FC group of PLC.

32: PLC restart: When [F0.03] is 9, this valid signal can make PLC start from the 1st step again at stop state or running. See parameter details of multi steps and FC group of PLC.

33: Swing frequency input

Swing frequency control, if set to manual input, when the terminal is valid, the swing frequency function is valid, the

inverter starts swing frequency operation. See parameter [FC.49-FC.55]

34: Swing frequency pause

Swing frequency control, when the terminal is valid, the inverter output frequency maintains constant current. The terminal command restores to swing frequency operation after revocation. See parameter [FC.49-FC.55]

35: Swing frequency reset

Swing frequency control, when the terminal is valid, the inverter runs with center frequency. The terminal command restores to swing frequency operation after revocation. See parameter [FC.49-FC.55]

36: Frequency channel switch terminal 1

37: Frequency channel switch terminal 2

38: Frequency channel switch terminal 3

39: Frequency channel switch terminal 4

It is valid only when [F0.03] is set as 12. Main frequency input channel is selected by terminal. 4 terminals can be combined to 0-11 which is corresponding to frequency input channels 0-11 of [F0.03]. Details refer to [F0.03].

40: Timer touch terminal valid when closed. Detail refers to [F2.25-F2.26].

41: Timer clear terminal valid when closed. Detail refers to [F2.25-F2.26].

42: Counter clock input terminal Detail refer to [F2.27-F2.28].

43: Counter clear terminal valid when closed. Detail refers to [F2.27-F2.28].

44: DC brake order: At stop state, it can start DC brake function. Details refer to [F1.09]. If input run order or JOG order, DC braking will be stopped.

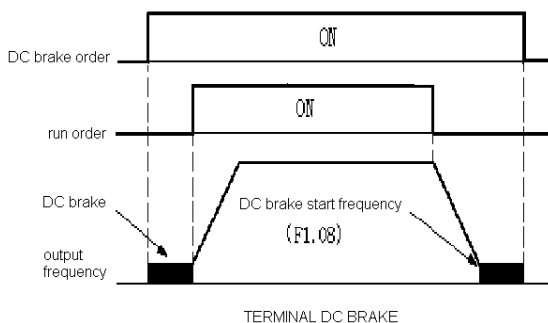

45: Pre-excitation order terminal: At stop state, it can start pre-excitation function. If inputting run or JOG order, pre-excitation order would be cancelled.

46: Reserved

47: Reserved

F2.07	Reserved		
F2.08	X1-X4 terminal trait selection	Setting range: 0000-1111	Factory default: 0000
F2.09	X1-X4 input terminal filter time	Setting range: 0.000-60.000s	Factory default: 0.010s

X1-X4 terminal trait selection: set multi-function input terminals X1, X2, X3, X4 features.

LED "0" digit: X1 terminal

0: On valid

1: Off valid

LED "00" digit: X2 terminal

0: On valid

1: Off valid
 LED "000" digit: X3 terminal
 0: On valid
 1: Off valid
 LED "0000" digit: X4 terminal
 0: On valid
 1: Off valid

X1-X4 input terminal filter time: When input terminal state changes, only if changed state keeps after filter time setting, it is considered as valid terminal state change. Otherwise, it keeps last state to effectively avoid misact caused by disturbance.

F2.10	X5-X7 terminal trait selection	Setting range: 0000-1111	Factory default: 0000
F2.11	X5-X7 input terminal filter time	Setting range: 0.000-60.000s	Factory default: 0.010s

Same as above

F2.12	Terminal control mode	Setting range: 0-3	Factory default: 0
-------	-----------------------	--------------------	--------------------

The parameter defines the 4 different ways of controlling the inverter operation by external terminals.
0:2-line 1 Run and direction in 1.Factory set is X1(FWD), X2(REV) terminals decide motor forward or reverse.

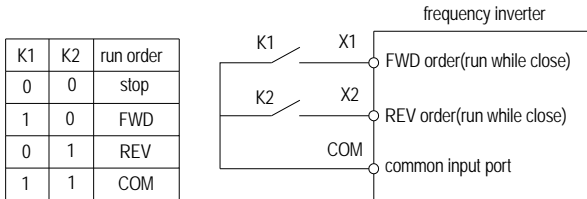

0: 2-line 1

1:2-line 2 Run and direction is separate. FWD terminal X1 is run terminal. FWD terminal X2 state decides direction.

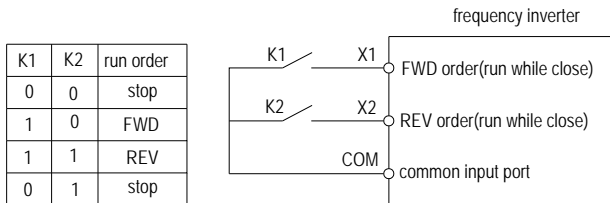

1: 2-line 2

2:3-line 1 Xi is stop run terminal. Run order is decided by FWD terminal X1. Direction is controlled by REV terminal X2. Xi is valid input.

K1	direction control
0	FWD
1	REV

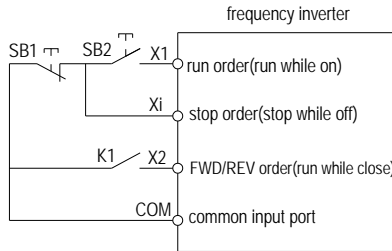

2: 3-line 1

3:3-line 2 Xi is stop run terminal. Run order is decided by FWD terminal X1or REV terminal X2. Direction is controlled by both terminals.

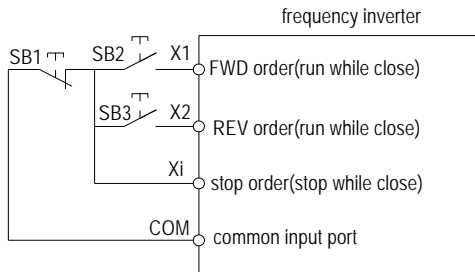

3: 3-line 2

Note: SB1: Stop Button. SB2: FWD Button. SB3: REV Button; Xi is set as 3 multi function input terminal [3 line control (Xi)].

F2.13	Terminal act mode	Setting range: 0000-0111	Factory default: 0111
-------	-------------------	--------------------------	-----------------------

The following states are valid only when the terminal control [F0.02] is set to "1", and only valid when [F0.02] is 1 and [F2.12] is set as 0 or 1. Running command must be re-entered when under three-line control mode.

LED "0" digit: free stop terminal reset mode

0: Reset to original order when invalid

1: Not reset to original order when invalid

LED "00" digit: emergency stop terminal reset mode

0: Reset to original order when invalid

1: Not reset to original order when invalid

LED "000" digit: terminal run mode after fault reset

0: Terminal control to power on directly

1: Terminal control to power on after stop

LED "0000" digit: reserved

Note: 3 channels given can send reset signal to inverter when fault alarm. If it is terminal control mode, inverter can select whether to carry out terminal order by these parameters when receiving reset signal of terminal or the other two channels.

F2.14-F2.15	reserved
-------------	----------

F2.16	PUL input min frequency	Setting range: 0.00-50.00kHz	Factory default: 0.00kHz
F2.17	PUL min frequency corresponding setting	Setting range: 0.00-100.00%	Factory default: 0.00%
F2.18	PUL input max frequency	Setting range: 0.00-50.00kHz	Factory default: 50.00kHz
F2.19	PUL max frequency corresponding setting	Setting range: 0.00-100.00%	Factory default: 100.00%
F2.20	PUL filter time	Setting range: 0.00-10.00s	Factory default: 0.10s
F2.21	PUL end frequency	Setting range: 0.000-1.000kHz	Factory default:0.010kHz

PUL input min frequency: It defines the smallest frequency that pulse input terminal (PUL) can accept. If smaller than this value, inverter will deal as min frequency.

PUL min frequency corresponding setting: It defines the ratio of setting value corresponding to PUL min input frequency.

PUL input max frequency: It defines the max frequency that pulse input terminal (PUL) can accept. If bigger than this value, inverter will deal as max frequency.

PUL max frequency corresponding setting: It defines the ratio of setting value corresponding to PUL max input frequency.

PUL filter time: It is pulse signal filter time to eliminate disturb signal. The longer filter time is, the stronger anti-disturb force is. The shorter filter time is, the weaker anti-disturb force is. But respond speed will be quicker.

PUL end frequency: It is defined as smallest pulse frequency can be identified by PUL. Pulse frequency lower than this value would be identified. It will be deal as 0Hz. The smaller this value is, the smaller the pulse frequency identified by PUL is. When PUL frequency is disappeared, the time of 0Hz pulse frequency judged by inverter is longer.

Note: F2.06 must be 0, when using PUL input.

F2.22	UP/DW terminal frequency adjust selection	Setting range: 0-2	Factory default: 0
F2.23	UP/DW terminal frequency add/reduce speed	Setting range: 0.01-50.00Hz/s	Factory default: 0.50Hz/s

UP/DW Terminal Frequency Adjustment Selection

0: Power down save When UP/DW adjustment, it saves frequency records after power down or stop. Inverter continues last UP/DW adjustment when power on.

1: Power down not save, stop save When UP/DW adjustment, it saves frequency records after stop. Inverter continues last UP/DW adjustment when power on. it does not save frequency record after power down. Inverter runs from 0.00Hz.

2: Valid in running, clear zero at stop When UP/DW adjustment, it does not save frequency records after power down or stop. Inverter continues last UP/DW adjustment when power on. Inverter UP/DW adjusts from 0.00Hz next time.

UP/DW terminal frequency increase/reduce speed: When UP/DW adjustment, it modifies change rate of give frequency.

F2.24	Reserved		
-------	----------	--	--

F2.25	Time unit for timer	Setting range: 0-2	Factory default: 0
F2.26	Timer setting	Setting range: 0-65000	Factory default: 0

Time unit for timer

- 0: Second
 1: Minute
 2: Hour

Timer setting: It is used for set timing of inverter. Timer start is finished by out timer touch terminal (select by [F2.00-F2.07]). Time begins when receiving signal. When time arriving, corresponding output terminal (selected by [F2.29-F2.31]) outputs 1s wide pulse signal. If out touch signal always at touching state, corresponding output terminal output one pulse signal every [F2.26] setting time.

When touch terminal is invalid, timer keeps records and continues when touch terminal is valid again.

Timer clear terminal can clear timer records anytime.

Note: Timer can work alone, not limited by the running state of inverter; the inverter timer could be used in certain conditions; timing can be displayed in [C-35], the time unit decided by [F2.25].

F2.27	Max value of counter	Setting range: 0-65000	Factory default: 1000
F2.28	Setting value of counter	Setting range: 0-65000	Factory default: 500

This parameter stipulates the counting action of the internal counter, clock terminal of the counter is selected by the parameter [F2.00-F2.06].

Max value of counter: When the count value of counter for the external clock reaches the value specified in [F2.27], in the corresponding output terminal (selected by [F2.29-2.31]) output a valid signal of which the width is equal to external clock period.

Setting value of counter: When the count value of counter for the external clock reaches the value specified in [F2.28], in the corresponding output terminal (selected by [F2.29-2.31]) output a valid signal; keep counting until the count value exceeds the value specified in [F2.27], which causes the counter to be cleared, and the output valid signal would be cancelled.

Counter can be clear zero anytime by multifunction terminal [F2.00-2.06].

The clock period requirement of the counter is greater than $10\text{ms} + [\text{F2.09}, \text{F2.11}, \text{F2.72}] \times 2$; the minimum pulse width is $5\text{ms} + [\text{F2.09}, \text{F2.11}, \text{F2.72}]$.

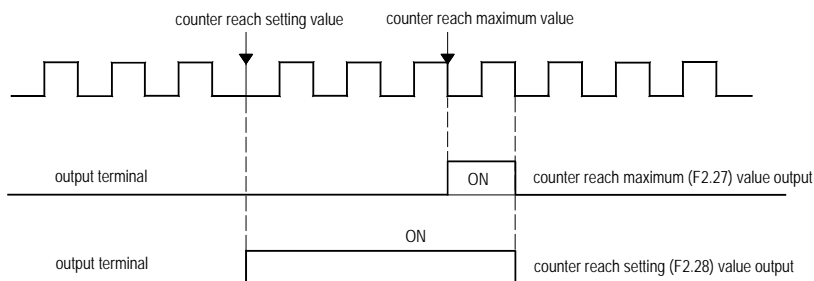

Note: When X1 ~ X7 is selected as the counter input, the function code [F2.09, F2.11, F2.72] filter time will affect the minimum input pulse cycle and pulse width for the count.

Tip: Timer can work alone, not limited by the running state of inverter; the inverter timer could be used in certain conditions; timing can be displayed in [C-22].

F2.29	Output terminal 1(Y)	Setting range: 0-28	Factory default: 0
F2.30	Relay output terminal (TA1-TB1-TC1)		Factory default: 1
F2.31	Relay output terminal (TA2-TB2-TC2)		Factory default: 3

0: No output

1: Running

2: REV running

3: Fault trip alarm 1(alarm when fault self-recover)

4: Fault trip alarm 2(no alarm when fault self-recover)

5: In the fault retry

6: External fault stop

7: Under voltage: The frequency converter displays "E.LU1/2" for the voltage is excessively low, output signal.

8: inverter operation preparation completed

9: Output frequency level test 1(FDT1)

10: Output frequency level test 2(FDT2) When the output frequency of frequency converter is over test level [F2.32]/[F2.34] setting, it outputs valid signal after [F2.33]/[F2.35] delay frequency. When output frequency is lower than test level, it outputs invalid signal after delay frequency. Details see [F2.32-F2.35].

11: Reaching given frequency Details see [F2.36].

12: Run with 0 speed

13: Upper frequency limit reached

14: Lower frequency limit reached

15: Program running cycle completed: One cycle finished, it output 500ms signal.

16: Program running step completed

17:PID feedback over upper limit When PID feedback arrive [Fb.16] and still over limit after [Fb.14] delay time, it output valid signal.

18:PID feedback under lower limit When PID feedback arrive [Fb.17] and still over limit after [Fb.14] delay time, it output valid signal.

19: PID feedback sensor wire break Details see [Fb.14-Fb.17].

20: Pre alarm for motor overload

21: Timer time reach Details see [F2.25-F2.26].

22: Counter reach biggest value Details see [F2.27-F2.28].

23: Counter reach set value Details see [F2.27-F2.28].

24: Energy braking Details see [FA.08].

25: PG feedback break Details see [F5.15-F5.17].

26: Emergency stop

27: Pre alarm output for over load It output valid signal when output current arrive or over [F2.37] and after [F2.38] delay time.

28: Pre alarm output for under load It output valid signal when output current is smaller or equal to [F2.39] and after [F2.40] delay time.

Note:

1, Relay output terminal TA1-TC1 on and TB1-TC1 off is valid signal. Relay output terminal TA2-TC2 on and TB2-TC2 off is valid signal. Y output terminal with low electrical level combined with (+24V) terminal outputting 24V power is valid signal.

2, To ensure the output terminal selection function key physical presence of non-duplicative, the actual settings would against each other, such as when [F2.29] = 1 the F2.30 will not be set to 1 instead it or [F2.31] or [F2.74-F2.75].

F2.32	Output frequency level 1(FDT1)	Setting range: 0.00- Max frequency	Factory default: 30.00Hz
F2.33	FDT1 lag	Setting range: 0.00- Max frequency	Factory default: 0.00Hz
F2.34	Output frequency level 2(FDT2)	Setting range: 0.00- Max frequency	Factory default: 50.00Hz
F2.35	FDT2 lag	Setting range: 0.00- Max frequency	Factory default: 0.00Hz

The parameter is used to set frequency test level. When output frequency reaches or exceeds the set value of [F2.32]/[F2.34], FDT 1/2 terminal outputs signal after [F2.33]/[F2.35] delay frequency. When output reaches or lower than the set value of [F2.32]/[F2.34], FDT 1/2 terminal stops output signal after [F2.33]/[F2.35] delay frequency.

F2.36	Given frequency reaches checkout range	Setting range: 0.00-50.00Hz	Factory default: 0.00Hz
-------	--	-----------------------------	-------------------------

When output frequency reaches or approaches the given frequency, output terminal Y/TA1-TB1-TC1/TA2-TB2-TC2 output valid signal if it is selected as "given frequency reached". This function can be used to adjust the test range offset.

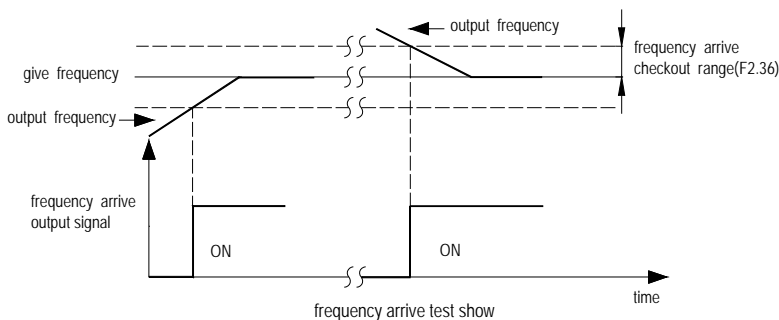

F2.37	Over load pre alarm level	Setting range: 0.0-200.0%	Factory default: 180.0%
F2.38	Over load pre alarm delay	Setting range: 0.0-100.0s	Factory default: 0.5s

When output current exceeds [F2.37] setting continuously, the output terminal outputs valid signal after [F2.38] delay frequency. When output current is lower than [F2.37] setting, the output terminal outputs invalid signal after [F2.38] delay frequency.

F2.39	Under load pre alarm level	Setting range: 0.0-200.0%	Factory default: 30.0%
F2.40	Under load pre alarm delay	Setting range: 0.0-100.0s	Factory default: 0.5s

When output current is equal to or lower than [F2.39] setting, the output terminal outputs valid signal after [F2.40] delay frequency. When output current is higher than [F2.39] setting, the output terminal outputs invalid signal after [F2.40] delay frequency. 100.00% corresponding to motor rated current.

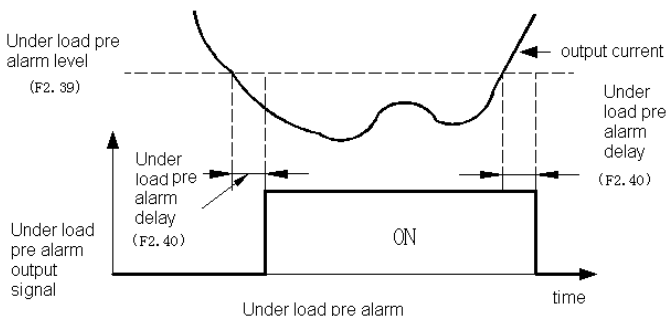

F2.41	X8-X10 extended terminals trait selection	Setting range:0.000-360.0s	Factory default: 0
F2.42	X11-X13 extended terminals trait selection		
F2.43	X8-X10 extended terminals on/off selection		
F2.44	X11-X13 extended terminals on/off selection		
F2.45	Multifunction terminal (X8)		
F2.46	Multifunction terminal (X9)		

When X1 - X3 terminal input status changed after a delay time, the inverter would then regard the current input terminal as an internal process.

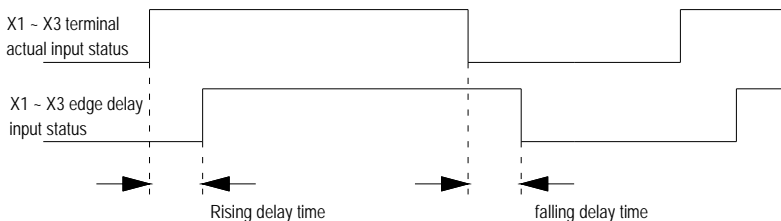

X1 - X3 edge delay input diagram

Note: rising edge delay time can't be greater than the actual input high pulse width time, and also the falling delay time can't be greater than the actual low pulse width time. Otherwise there would be an invalid input status.

F2.47	Y output delaying time	Setting range: 0.0-360.0s	Factory default: 0
-------	------------------------	---------------------------	--------------------

When the internal logic of the inverter operation is to change the Y terminal status, change after a set time delay after the actual state of the output terminals Y, wherein the delay time considerations are the same as the input terminal.

F2.48	output delay time of relay 1	Setting range: 0.0-360.0s	Factory default: 0
F2.49	output delay time of relay 2		

Same as the Y output delay time of [F2.47].

F2.50	Reserved
-------	----------

F2.51	Virtual vX1terminal function selection	Setting range: 0-47	Factory default: 0
F2.52	Virtual vX2terminal function selection		
F2.53	Virtual vX3terminal function selection		
F2.54	Virtual vX4terminal function selection		

Virtual vX1-vX4 are the same in terms of function with the X1-X7 on the control panel, which can be used as the multi-functional digital input; please refer to [F2.00-F2.06] for detailed information.

F2.55	vX terminal valid state source	Setting range: 0000-1111	Factory default: 0000
-------	--------------------------------	--------------------------	-----------------------

LED "0"digit: virtual vX1

LED"00"digit: Virtual vX2

LED "000"digit: Virtual vX3

LED"0000"digit: Virtual vX4

0: internal connection to the virtual vYi; vYi state to decide whether vXi valid (i = 1- 4) or not.

1: set by function code [F2.56].

Virtual vX1 ~ vX4 input terminal status can be set in two ways, selected by [F2.55]; when the state of vX1 ~ vX4 is determined by the state of virtual vY1 ~ vY4, whether vX1 ~ vX4 is valid or not is depend on vY1 ~ vY4 output, and vX1 ~ vX4 and vY1 ~ vY4 are tied together.

When selecting state of vX1 ~ vX4 is set by the function code, the corresponding input terminals can be set respectively through the function code [F5.56]

F2.56	Virtual vX terminal function code setting valid state	Setting range: 0000-1111	Factory default: 0000
-------	---	--------------------------	-----------------------

LED "0"digit: virtual vX1

LED"00"digit: Virtual vX2

LED "000"digit: Virtual vX3

LED"0000"digit: Virtual vX4

0: vXi invalid.

1: vXi valid. (i = 1-4)

F2.57	VS terminal function selecting(as X)	Setting range: 0-47	Factory default: 0
F2.58	AI terminal function selecting(as X)		
F2.59	AS terminal function selecting(as X)		

Analog input terminal X and function selection is the same as X1-X7, for detailed description see [F2.00-F2.06].

When the analog terminal input X, high electrical level when the analog voltage exceeds 7V; low electrical level when

the analog voltage is less than 3V; hysteresis loop when 3V-7V; high electrical level when the analog current exceeds 14mA; low electrical level when the analog current is less than 6mA; hysteresis loop when 6mA -14mA, the input level remains unchanged during hysteresis

F2.60	Analog terminal effective status setting	Setting range: 000-111	Factory default: 000
-------	--	------------------------	----------------------

LED "0" digit: VS

LED "00" digit: AI

LED "000" digit: AS

0: low electrical level valid

1: high electrical level valid

F2.61-F2.64	Virtual vY1-vY4 output selection	Setting range: 0-28	Factory default: 0
-------------	----------------------------------	---------------------	--------------------

Virtual terminals vY1 ~ vY4 output function selection with Y terminal and relay detailed description see [F2.29-F2.31].

F2.65-F2.68	Virtual vY1-vY4 output delay time	Setting range: 0.0-999.9s	Factory default: 0
-------------	-----------------------------------	---------------------------	--------------------

Virtual terminals vY1 ~ vY4 output delay settings with Y terminals and relay detailed description see [F2.47-F2.49].

Virtual Terminal feature is the combination of vXi and vYi, setting Y terminal output signal as X terminal input signal can be realized through internal vXi connecting with vYi virtual, thus saving the actual X and Y terminals.

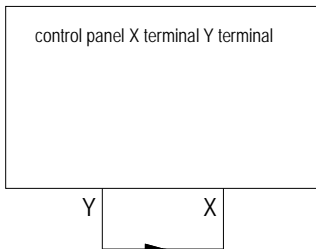

Connecting by external X and Y terminal

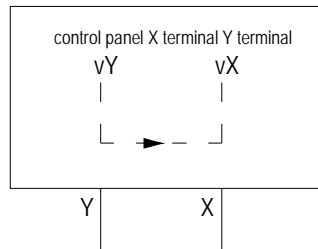

Connecting by virtual terminal internal connection

The following example illustrates the application of virtual vX and vY:

Example 1: cases requires the inverter ready to run when the initialization is completed, under normal conditions an X input terminal would be used; if using a virtual terminal, the real X terminal can be used for other inputs, as follows:

Set F0.02 = 1 Run command source terminal control;

Set F2.12 = 0 two-line control 1;

Set F2.51 = 1 terminal inputs forward run;

Set F2.55 = 0000 vX1 effective state is determined by vY1;

Set F2.61 = 8 output when inverter operation ready.

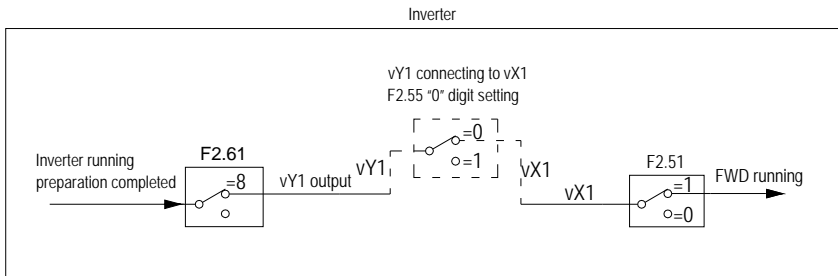

2 line control 1 virtual terminal control

Example 2: cases requires the inverter forward run after 60s delay when the the inverter electrified, as follows:

Set F0.02 = 1 Run command source terminal control, F2.12 = 2 Three-line control 1;

Set F2.26 = the timer counts 60s;

Set F2.51 = 1 vX1 terminal function input, run forward;

Set F2.52 = 3 vX2 terminal function input, three-line running control (Xi);

Set F2.53 = 40 vX3 terminal function input, timer trigger;

Set F2.55 = 0110 vX2 and vX3 active source is determined by "0"digit" and "00"digit of F2.56;

Set F2.56 = 0110 vX2, vX3 setting is valid;

Set F2.61 = 21 vY1 output when the timer reaches.

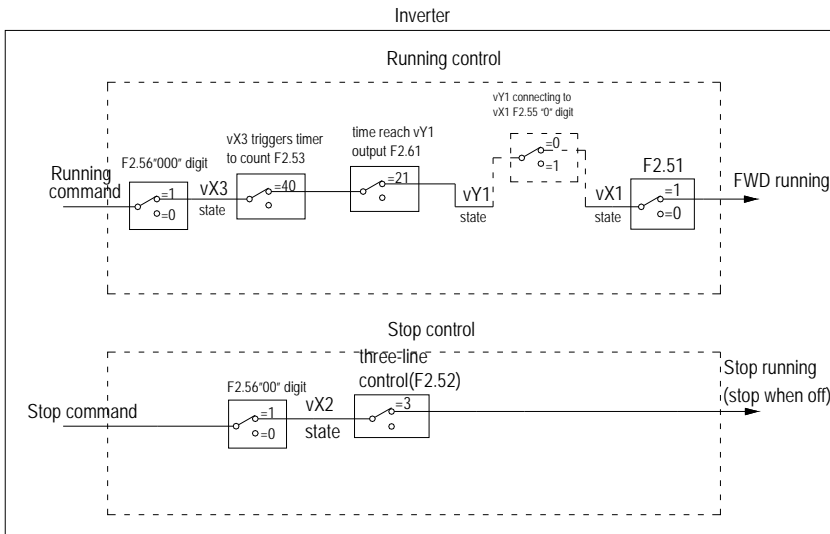

Note: It can be seen from the chart when using a conventional method requires access to two actual external X terminal, but if using virtual terminal, access to external actual terminal is not needed.

F2.69-F2.71	Terminal input extended (X8) Terminal input extended (X9) Terminal input extended (X10)	Setting range: 0-47	Factory default: 0
-------------	---	---------------------	--------------------

Expansion card terminals X8, X9, X10 function selection, please refer [F2.00-F2.06].

- Tip: 1, [F2.69-F2.71] and [F2.00-F2.06] Function Select Settings mutual exclusive;
2, the expansion of the use of the terminal must be optional terminal expansion card EXIO1

F2.72	X8-X10input terminal filter time	Setting range: 0.000 -60.000s	Factory default: 0.010s
F2.73	X8-X10 terminal feature selection	Setting range: 000-111	Factory default: 0x000

Same as [F2.08] and [F2.09]

F2.74	Output extended relay 3 (TA3-TC3)	See Y terminal function	Factory default: 0
F2.75	Output extended relay4 (TA4-TC4)		Factory default: 0

Extended relay output function selection, please refer [F2.29-F2.31], but there're only normal open contact points for T3, T4.

Tip: [F2.74-F2.75] and [F2.29-F2.31] function select settings mutual exclusive.

8.4 Analog Terminal Parameter

F3.00	VS Lower limit	Setting range: 0.00-10.00V	Factory default 0.00V
F3.01	VS Lower limit corresponding setting	Setting range: 0.00-100.00%	Factory default 0.00%
F3.02	VS upper limit	Setting range: 0.00-10.00V	Factory default 10.00V
F3.03	VS upper limit corresponding setting	Setting range: 0.00-100.00%	Factory default 100.00%
F3.04	VS filter time	Setting range: 0.00-10.00s	Factory default 0.10s

VS Lower limit: It defines signal accepted by analog input terminal (VS), Inverter deal voltage lower than this value as lower limit.

VS lower limit corresponding setting: It defines ratio of VS lower limit.

VS upper limit: It defines signal accepted by analog input terminal (VS). Inverter deal voltage higher than this value as higher limit.

VS upper limit corresponding setting: It defines ratio of VS upper limit.

VS filter time: It is (VS) input analog signal filter time to eliminate disturb signal. The longer filter time is, the stronger anti-disturb force is. The shorter filter time is, the weaker anti-disturb force is. But respond speed will be quicker.

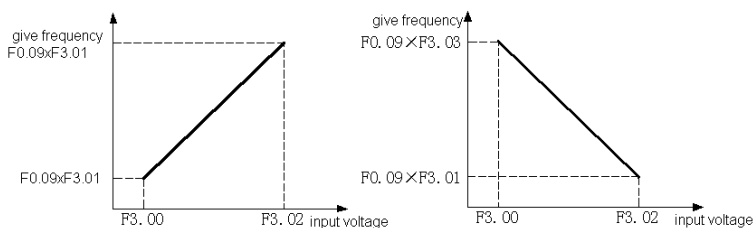

Analog give frequency show

F3.05	AI Lower limit when used as VS	Setting range: 0.00-10.00V	Factory default: 0.00V
F3.06	AI Lower limit corresponding setting	Setting range: 0.00-100.00%	Factory default: 0.00%
F3.07	AI upper limit when used as VS	Setting range: 0.00-10.00V	Factory default: 10.00V
F3.08	AI upper limit corresponding setting	Setting range: 0.00-100.00%	Factory default: 100.00%
F3.09	AI filter time	Setting range: 0.00-10.00s	Factory default: 0.10s
F3.10	AS Lower limit	Setting range: 0.00-20.00mA	Factory default: 4.00mA
F3.11	AS Lower limit corresponding setting	Setting range: 0.00-100.00%	Factory default: 0.00%
F3.12	AS upper limit	Setting range: 0.00-20.00mA	Factory default: 20.00mA
F3.13	AS upper limit corresponding setting	Setting range: 0.00-100.00%	Factory default: 100.00%
F3.14	AS filter time	Setting range: 0.00-10.00s	Factory default: 0.10s

See VS explain. AI (VS) indicates setting when the AV terminal input voltage analog.

F3.15	AI lower limit when used as AS	Setting range: 0.00-20.00mA	Factory default: 4.00mA
-------	--------------------------------	-----------------------------	-------------------------

LED "0"digit: VS

LED"00"digit: AI

LED "000"digit: AS

0: straight line By default, usually two points straight line, please refer to the above "given frequency analog schematic

1: curve 1 Multi-point stitches, see function code [F3.32-F3.39] description

2: curve 2 Multi-point stitches, see function code [F3.40-F3.47] description

F3.16	AI(AS) Lower limit	Setting range: 0.00-20.00mA	Factory default: 4.00mA
F3.17	AI(AS) Lower limit corresponding setting	Setting range: 0.00-100.00%	Factory default: 0.00%
F3.18	AI(AS) upper limit	Setting range: 0.00-20.00mA	Factory default: 20.00mA
F3.19	AI(AS) upper limit corresponding setting	Setting range: 0.00-100.00%	Factory default: 100.00%

Settings are the same as [F3.10-F3.13], AI (VS) indicates setting when the AI terminal input current analog.

F3.20	Reserved		
-------	----------	--	--

F3.21	A0 output signal type	Setting range: 0x00-0x32	Factory default: 0000
-------	-----------------------	--------------------------	-----------------------

"0"digit: AO1

0: 0-10V

1: 4.00-20.00mA

2: 0.00-20.00mA

"00"digit: AO2

0: 0-10V

1: 4.00-20.00mA

2: 0.00-20.00mA

3: FM frequency pulse output

Specify AO1, AO2 terminal output signal types, selectable output voltage, output current; AO2 can be used as pulse output.

Tip: After selecting output mode, you also need to select switch on-off mode on the control panel; S1 designated AO1 output, S5 designated AO2 output, for specific choice of the way, please see the connection terminals jumper Table 3-5; inverter factory software and hardware default is 0 ~ 10V output, if you need to change, please press the actual output signal to change the hardware and software at the same time.

F3.22	A01 output selection	Setting range: 0-17	Factory default: 0
F3.23	A02 output selection		Factory default:1

Used for setting inverter monitor value corresponding to multifunction terminal (AO1), (AO2) output signal.

(AO1) output signal is decided by "0" digit of [F3.21].

(AO2) output signal is decided by "00" digit of [F3.21].

Setting	Monitor value	Function	AO min output	AO max output
0	Give frequency	Corresponding to current give frequency	Min output corresponding to 0.00Hz	Max output corresponding to max frequency
1	Output frequency	Corresponding to current output frequency	Min output corresponding to 0.00Hz	Max output corresponding to max frequency
2	Output current	Corresponding to current output current	Min output corresponding to 0.00A	Max output corresponding to 2 times of rated current
3	Input voltage	Corresponding to current input voltage	Min output corresponding to 0V	Max output corresponding to 2 times of rated voltage
4	Output voltage	Corresponding to current output voltage	Min output corresponding to	Max output corresponding to 2 times of rated voltage
5	Machine speed	Corresponding to current machine speed	Min output corresponding to 0 speed	Max output corresponding to speed corresponding to max frequency
6	Reserved	Reserved	Reserved	Reserved
7	Output torque	Corresponding to current output torque	Min output corresponding to 0.00% torque	Max output corresponding to 200% torque
8	PID give	Corresponding to current PID give	Min output corresponding to 0.00% PID give	Max output corresponding to 200% PID give
9	PID feedback	Corresponding to current PID feedback	Min output corresponding to 0.00% PID feedback	Max output corresponding to 100% PID feedback
10	Output power	Corresponding to current output power	Min output corresponding to 0 power	Max output corresponding to rated output power
11	Bus voltage	Corresponding to current input voltage	Min output corresponding to 0V	Max output corresponding to 2 times rated DC voltage ²
12	VS input	Corresponding to current VS input	Min output corresponding to VS input lower limit	Max output corresponding to VS input upper limit
13	AI input	Corresponding to current AI input	Min output corresponding to AI input lower limit	Max output corresponding to AI input upper limit
14	AS input	Corresponding to current AS input	Min output corresponding to AS input lower limit	Max output corresponding to AS input upper limit

15	PUL input	Corresponding to current PUL input	Min output corresponding to PUL input lower limit	Max output corresponding to PUL input upper limit
16	Module temperature 1	Corresponding to current module temperature 1	Min output corresponding to 0 degree module temperature 1	Max output corresponding to module temperature 1 is 100 degree
17	Module temperature 2	Corresponding to current module temperature 2	Min output corresponding to 0 degree module temperature 2	Max output corresponding to module temperature 2 is 100 degree

F3.24	A01 output gain	Setting range: 25.0-200.0%	Factory default: 100.0%
F3.25	A01 output signal bias	Setting range: -10.0-10.0%	Factory default: 0.0%

A01 output gain: It is used for adjusting A01 terminal output analog value.

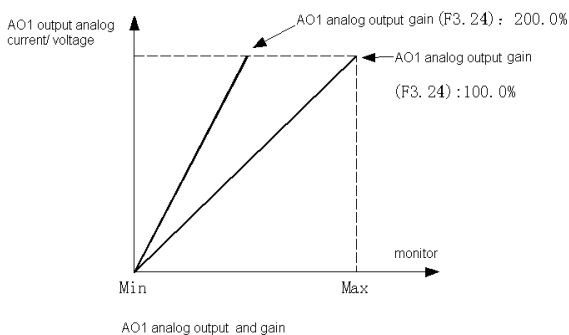

A01 output signal bias: It is used for adjusting A01 terminal 0 point of output signal.

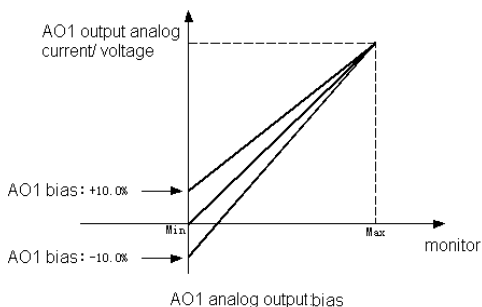

Note: A01 output terminal includes voltage output and current output. Please select K2, when used as 0-10V output; Please select K1, when used as 0-20mA output. All is used as 0-10V output in factory default hardware setting.

F3.26	Reserved
-------	----------

F3.27	A02 output gain	Setting range: 25.0-200.0%	Factory default : 100.0%
F3.28	A02 output signal bias	Setting range: -10.0-10.0%	Factory default : 0.0%

Please see AO1 parameter specification.

F3.29	A02FM frequency output Lower limit	Setting range: 0.00-50.00kHz	Factory default: 0.20kHz
F3.30	A02FM frequency output upper limit	Setting range: 0.00-50.00kHz	Factory default: 50.00kHz

When A02 is set as FM frequency pulse output, it is lower limit and upper limit of the signal.

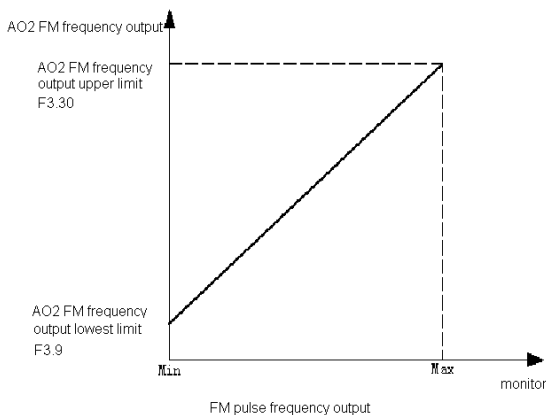

F3.31	Reserved		
-------	----------	--	--

F3.32	Curve 1 start input	Setting range: 0.00-10.00V	Factory default: 0.00V
F3.33	Curve 1 start input corresponding set	Setting range: 0.00-100.00%	Factory default: 0.0%
F3.34	Curve 1 inflection point 1 input	Setting range: F3.32-10.00V	Factory default: 3.00V
F3.35	Curve 1 inflection point 1 input corresponding set	Setting range: 0.00-100.00%	Factory default: 30.0%
F3.36	Curve 1 inflection point 2 input	Setting range: F3.34-10.00V	Factory default: 6.00V
F3.37	Curve 1 inflection point 2 input corresponding set	Setting range: 0.00-100.00%	Factory default: 60.0%
F3.38	Curve 1 end point input	Setting range: F3.36-10.00V	Factory default: 10.00V
F3.39	Curve 1 end point input corresponding set	Setting range: 0.00-100.00%	Factory default: 100.0%
F3.40	Curve 2 start point input	Setting range: 0.00-10.00V	Factory default: 0.00V
F3.41	Curve 2 start point input corresponding set	Setting range: 0.00-100.00%	Factory default: 0.0%
F3.42	Curve 2 inflection point 1 input	Setting range: F3.40-10.00V	Factory default: 3.00V
F3.43	Curve 2 inflection point 1 input corresponding set	Setting range: 0.00-100.00%	Factory default: 30.0%
F3.44	Curve 2 inflection point 2 input	Setting range: F3.42-10.00V	Factory default: 6.00V
F3.45	Curve 2 inflection point 2 input corresponding set	Setting range: 0.00-100.00%	Factory default: 60.0%

F3.46	Curve 2 end point input	Setting range: F3.44-10.00V	Factory default: 10.00V
F3.47	Curve 2 end point input corresponding set	Setting range: 0.00-100.00%	Factory default: 100.0%z

Curves 1 and curve 2 can be set with two inflection points, a straight line is divided into three sections, and each slope may not be the same, to achieve a more flexible correspondence, as shown below:

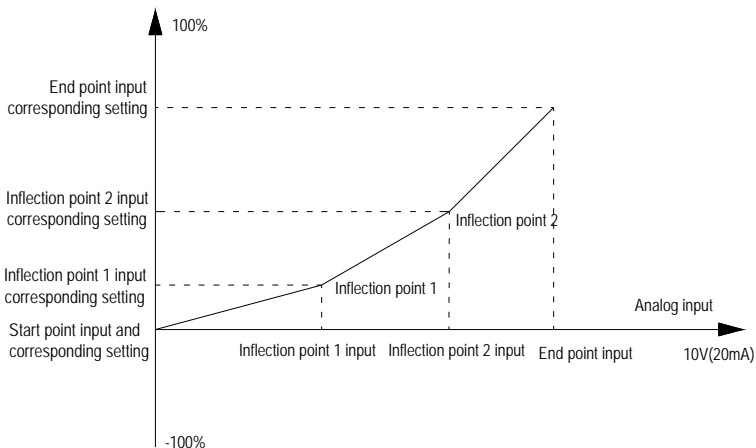

If Curve 1 or Curve 2 AA is selected by AS or AI (AS), current should be converted to voltage, current and voltage settings are stating twice relations, 4mA corresponds to 2V, 20mA corresponds to 10V.

Note: [F3.32, F3.34, F3.36, F3.38] and [F3.40, F3.42, F3.44, F3.46] showed the input voltage value should be in an increasing mode.

F3.48	VS3 Lower limit	Setting range: -10.00V -10.00V	Factory default: -10.00V
F3.49	VS3 Lower limit corresponding setting	Setting range: -100.00% -100.00%	Factory default: -100.00%
F3.50	VS3 upper limit	Setting range: -10.00V-10.00V	Factory default: 10.00V
F3.51	VS3 upper limit corresponding setting	Setting range: -100.00% -100.00%	Factory default: 100.00%
F3.52	VS3 filter time	Setting range: 0.00-10.00s	Factory default: 0.10s

Set an expansion card analog input mapping curve VS3, the same as [F3.00]-[F3.04]; but VS3 supports positive and negative direction input, when given as a frequency source, transformation between the two directions can be achieved.

8.5 Keyboard and Display Parameters

F4.00	Parameter and key lock selections	Setting range: 0-3	Factory default: 0
-------	-----------------------------------	--------------------	--------------------

0: **Unlock** Parameter and keyboard lock function invalid.

1: **Parameter lock**: Lock all function parameter settings, can't modify (except the F0.08). Keyboard can't log in the parameter setting. All buttons in the keypad are unlocked.

2: **Parameter and key lock (except FWD/STOP/JOG)** Lock all parameter settings, can't modify. And lock all keys on keyboard except FWD/STOP/JOG.

3: **All parameter and key lock**: Lock all parameter settings, can't modify. And lock all keys on keyboard except PRG.

Note:

1. **Double lines keypad unlock method**: Press "PRG" and 1st line show "CodE". And use the "UP"- "DOWN" key and move to 2nd line, then enter password (F4.01-user password) and press "SET".

2. **Single line keypad unlock method**: Press "PRG" and show "CodE". Press "SET" then enter password (F4.01-user password) and press "SET" again and will be clear!

3. **User password is a parameter which purpose is to protect the inverter from tampering at will. In order to avoid bring inconvenience, please keep it confidential!**

F4.01	User password	Setting range: 0-9999	Factory default: 0
-------	---------------	-----------------------	--------------------

It is used to set user password. When [F4.00] is (not 0) lock state, password input is needed to unlock. Factory default is 0.

F4.02	REV/JOG selections	Setting range: 0-1	Factory default: 0
-------	--------------------	--------------------	--------------------

Used to select the REV/JOG function of the keyboard

0: **REV** When keyboard control, press this button, inverter reverse run. Key **REV/JOG** not light.

1: **JOG** When keyboard control, press this button, inverter JOG. Key **REV/JOG** light.

F4.03	STOP key function range	Setting range: 0000-0011	Factory default: 0000
-------	-------------------------	--------------------------	-----------------------

LED "0" digit: terminal control selection

0: **invalid to terminal order**: When terminal given signal, STOP key can't control to stop.

1: **valid to terminal order**: When terminal given signal, STOP key can control to stop.

LED "00" digit: communication control selection

0: **invalid to communication order**: When terminal given signal, STOP key can't control to stop.

1: **valid to communication order**: When terminal given signal, STOP key can control to stop.

LED "000" digit: reserved

LED "0000" digit: reserved

Note: When valid to terminal order or communication order, inverter is in stop lock state after press STOP. If inverter needs to restart, stop order needs to be given by selected order channel to unlock stop state firstly.

F4.04	UP/DOWN key modification selections	Setting range: 0000-0014	Factory default: 0011
-------	-------------------------------------	--------------------------	-----------------------

LED "0" digit: keyboard UN/DOWN key modify selection

0: **Invalid** UP/DOWN key can't modify parameters.

1: **Modify frequency setting by key board numbers (F0.08)** UP/DOWN key can modify settings of [F0.08].

2: Reserved

3: **Modify PID give setting by key board numbers (Fb.01)** UP/DOWN key can modify settings of [Fb.01].

4: Reserved

LED "00" digit: keyboard UN/DOWN key store selection

0: No save after power down

1: Save after power down

It is used to select whether to save the parameter modified by UP/DOWN key when power cut.

LED "000" digit: reserved

LED "0000" digit: reserved

F4.05	Function parameter copy	Setting range: 0-2	Factory default: 0
-------	-------------------------	--------------------	--------------------

0: No operation

1: Send machine parameters to keyboard and save store in the inverter. Copy the parameter group F0 to Fd to the keyboard and

2: Send parameters saved by keyboard to machine download the copied data of the keyboard into the inverter.

Note:

1. **Keyboard will not send stored parameters to inverter when inverter is running or in fault state or no data stored in keyboard.**

2. **When sending data to keyboard, if keyboard is out of inverter, it will not finish copy operation, and needs to retry it.**

3. **When sending data to inverter, if keyboard is out of inverter,, it will not finish download operation and needs to retry it.**

4. **When sending data to keyboard, current state of inverter will not be remained. And all keys are invalid when sending data to inverter.**

5. **If it displays E.CEP, operation of copy parameter will be interrupted and needing to retry it. Press STOP button to return monitor menu.**

6. **When software is not compatible, it shows E.EDI, and will not send data to inverter.**

F4.06	Reserved		
-------	----------	--	--

F4.07	Keyboard potentiometer lower limit	Setting range: 0.00-5.00V	Factory default: 0.50V
F4.08	Keyboard potentiometer lower limit corresponding setting	Setting range: 0.00-100.00%	Factory default: 0.00%
F4.09	Keyboard potentiometer upper limit	Setting range: 0.00-5.00V	Factory default: 4.50V
F4.10	Keyboard potentiometer upper limit corresponding setting	Setting range: 0.00-100.00%	Factory default: 100.00%

Keyboard potentiometer lower limit: It defines the lower limit of the signal given by potentiometer. Inverter treats the voltage lower than this value as the lower limit signal.

Keyboard potentiometer lower limit corresponding setting: It sets ratio of keyboard potentiometer lower limit.

Keyboard potentiometer upper limit: It defines the upper limit of the signal given by potentiometer. Inverter treats the voltage higher than this value as the lower limit signal.

Keyboard potentiometer upper limit corresponding setting: It set ratio of keyboard potentiometer upper limit.

F4.11	Upper LED display content when run	Setting range: 0000-FFFF	Factory default: 42B1
F4.12	Upper LED display content when stop	Setting range: 0000-FFFF	Factory default: 42B0

Upper LED display content when run: Set monitor content showed in the upper line of LED when running. The content can be modified by "SET" key when running. Not save modification when power cut. Default display LED "0" digit setting after power on.

Upper LED display content when stop: Set monitor content showed in the upper line of LED when stop. The content can be modified by "SET" key when stop. Not save modification when power cut. Default display LED "0" digit setting after power on.

LED "0" digit to "0000" digit settings:

0: Given frequency 1: Output frequency 2: Output current 3: Input voltage
 4: Output voltage 5: Machine speed 6: Reserved 7: Output torque
 8: PID given value 9: PID feedback value A: Output power B: Bus voltage
 C: Module temperature 1 D: Module temperature 2 E: ON/OFF state of input terminal X
 F: ON/OFF state of input terminal Y

F4.13	Lower LED display content when run	Setting range: 0000-FFFF	Factory default: CA42
F4.14	Lower LED display content when stop	Setting range: 0000-FFFF	Factory default: CA42

It is only valid when keyboard with 2 lines. Details refer to [F4.11-F4.12].

F4.15	Rotate speed display coefficient	Setting range: 0.1-5000.0%	Factory default: 100.0%
-------	----------------------------------	----------------------------	-------------------------

It sets the display coefficient of keyboard monitor item "machine speed" .100% is corresponding to motor rated speed.

F4.16	Keyboard display coefficient	Setting range: 0000-1111	Factory default: 0000
-------	------------------------------	--------------------------	-----------------------

LED "0" digit: LCD display language

0: Chinese
 1: English

LED"00" digit: output frequency selection

0: Aim frequency
 1: Actual frequency

LED"000" digit: machine speed display selection

0: Actual speed
 1: Aim speed

LED"0000" digit: reserved

8.6 Motor Parameters

F5.00	Motor type	Setting range: 0-1	Factory default:0
-------	------------	--------------------	-------------------

Motor type: Read-only parameter that indicates the current motor type, which is based on [F5.00] or [F5.31] motor control mode.

0: asynchronous motors (AM);

1: Synchronous Motor (PM)

F5.01	Motor rate	Setting range: 2-48	Factory default: 4
F5.02	Motor rated power	Setting range: 0.4-1000.0kW	Factory default: mode setting
F5.03	Motor rated frequency	Setting range: 0.01Hz-max frequency	Factory default: mode setting
F5.04	Motor rated speed	Setting range: 0-65000rpm	Factory default: mode setting
F5.05	Motor rated voltage	Setting range: 0-1500V	Factory default: mode setting
F5.06	Motor rated current	Setting range: 0.1-2000.0A	Factory default: mode setting

Set nameplate parameters; every time when motor rated power setting is changed, the inverter will automatically adjust default parameter as the [F5.03-F5.11] default. If self-study, parameters of [F5.07-F5.11] will automatically change according to the result of self-study. If high accuracy motor control is needed, please implement motor self study after correct setting of parameter [F5.01-F5.06].

F5.07	Motor no-load current	Setting range:0.01-650.00A	Factory default: mode setting
F5.08	Motor stator resistor	Setting range:0.001-65.000	Factory default: mode setting
F5.09	Motor rotor resistor	Setting range:0.001-65.000	Factory default: mode setting
F5.10	Motor stator inductance	Setting range:0.1-6500.0mH	Factory default: mode setting
F5.11	Stator mutual inductance	Setting range:0.1-6500.0mH	Factory default: mode setting

Asynchronous motor model parameter, when set [F5.12] parameters after the Auto-tuning, [F5.07 - F5.11] content will automatically change. If you know the exact parameters of the motor model, parameters self-tuning is not necessary; manually inputting the motor model parameters for commissioning.

F5.12	Parameters self-tuning selections	Setting range: 0-2	Factory default: 0
-------	-----------------------------------	--------------------	--------------------

0: No operation: Set as default without self study.

1: Rotary type self-study: Before self tuning, please correctly input the parameter value [F5.01-F5.06] of asynchronous motor which is controlled. During rotary tuning, firstly, asynchronous motor at static state, it automatically detects motor stator resistance, motor rotor resistance, motor stator & rotor inductance. Then the asynchronous motor at rotate state, it automatically detects motor no-load current, motor stator & rotor mutual inductance. All results will be auto written in [F5.08], [F5.09], [F5.10] and [F5.07],[F5.11] and renewed when rotary tuning is over. After parameter setting, press FWD key to start self study, keyboard LED display "t-01". Motor automatically stops when self tuning is over. Inverter recovers to standby state.

2: static type self-study: Before self tuning, please correctly input the parameter value [F5.01-F5.06] of asynchronous motor which is controlled. During static tuning, motor at static state, it automatically detects motor stator resistance, motor rotor resistance, motor stator & rotor inductance. All results will be auto written in [F5.08], [F5.09], [F5.10] and renewed when static tuning is over. After parameter setting, press FWD key to start self study, keyboard LED displays "t-02". FWD indicator is off when self tuning is over. Inverter recovers to standby state.

Note: [F5.12] is automatic set as 0 after self tuning.

Attention: 1. Before setting [F5.12] as 1 –self study, unload the motor firstly.

2. In some occasions (such as can't unload), if it can't self study or it is not high control accuracy required,

- static self study or no self study is ok. If no self study, please do set right parameters [F5.01-F5.06]
3. If user know the right parameter. User can set [F5.01-F5.11] directly.
 4. Ensure stop state before starting self study, otherwise, self study can't be normal.
 5. When [F5.12] is 1, if there is over voltage or over current in self study process, ACC/DEC time [F0.14, F0.15] can be prolonged.
 6. If static self study is not successful, alarm E.tE1 fault. If rotary self study is not successful, alarm E.tE2 fault.

F5.13-F5.14	Reserved
-------------	----------

F5.15	Speed feedback or encoder type	Setting range: 0000-2113	Factory default: 0000
-------	--------------------------------	--------------------------	-----------------------

LED "0" digit: encoder type: set encoder type according to the encoders actually selected.

0: Normal ABZ encoder

1: Resolver

2: UVW encoder

3: wire-saving UVW encoder

LED "00" digit: encoder direction: When motor speed direction and encoder speed direction is inconsistent, switch direction by setting the parameter.

0: same direction;

1: opposite direction

LED "000" digit: disconnection detection: when the break detection is turned on, the inverter would report encoder failure and stop when encoder disconnection is found.

0: Close

1: Open

LED "0000" digit: PG card selection: Select the encoder signal source; AC100 supports three motor speed signal ports.

0: PG port 1

1: PG port 2

2: PUL pulse input

F5.16	Photoelectric encoder lines	Setting range: 0-60000	Factory default: 1024
-------	-----------------------------	------------------------	-----------------------

Photoelectric encoder lines: used to set output pulse of speed feedback sensor per week; please set correctly according to the sensor specification.

F5.17	PG line-break detection time	Setting range: 0.100-60.000s	Factory default: 0.000s
-------	------------------------------	------------------------------	-------------------------

PG line-break detection time: used to confirm sensor disconnection delay time when the sensor break detection setting is valid; set 0sec as the off function of line-break detection.

F5.18	Resolver poles	Setting range: 2-128	Factory default: 2
-------	----------------	----------------------	--------------------

Resolver poles: Set according to actual selection of resolver, usually 2-pole resolver

F5.19	Encoder installation reduction ratio	Setting range: 0.100-50.000	Factory default:1.000
-------	--------------------------------------	-----------------------------	-----------------------

When the encoder and motor rotor is not coaxially mounted, the motor speed detection can be achieved by setting the parameter.

$$\text{Motor speed} = \text{encoder detected speed} \times \text{F5.19}$$

F5.20	Reserved		
-------	----------	--	--

F5.21	Synchronous machine stator resistance	Setting range: 0.001-65.000	Factory default: Model set
F5.22	Synchronous machine d-axis inductance	Setting range: 0.01mH-655.35mH	Factory default: Model set
F5.23	Synchronous machine q-axis inductance	Setting range: 0.01mH-655.35mH	Factory default: Model set
F5.24	Synchronous machine back electromotive force	Setting range: 0.1V-1000.0V	Factory default: Model set

PMSM model parameters, of which the back electromotive force represents the voltage measured between lines when the motor rotor speed is set to the rated frequency speed; motor model parameters will automatically identify and modify in the motor parameter self-tuning. Wherein, [F5.24] will be recognized only in a rotating auto-tuning.

F5.25	Synchronous machine encoder installation angle	Setting range: 0.0° -360.0°	Factory default: Model set
-------	--	-----------------------------	----------------------------

When synchronous machines are running VC with PG (F0.00 = 7), this parameter is required to detect the magnetic pole position of the rotor. This parameter can be automatically identified and modified during the rotating auto-tuning, and generally it does not need adjustment.

F5.26	High frequency injection frequency	Setting range: 50.0Hz-1000.0Hz	Factory default: 300.0Hz
F5.27	High frequency injection voltage	Setting range: 0.1%-100.0%	Factory default: 20.0%
F5.28	BEMF current identification	Setting range: 0.1%-100.0%	Factory default: 80.0%

Synchronous machine parameters self-tuning parameters do not need adjustment usually.

8.7 VC Parameters

F6.00	ASR proportional gain 1	Setting range: 0.00-1.00	Factory default: 0.20
F6.01	ASR integral time 1	Setting range: 0.01-10.00s	Factory default: 0.50
F6.02	ASR differential coefficient time 1	Setting range: 0.0-100.0	Factory default: 0.0
F6.03	ASR filter time1	Setting range: 0.000-0.100s	Factory default: 0.005s
F6.04	ASR switch frequency 1	Setting range: 0.00-50.00Hz	Factory default: 5.00Hz
F6.05	ASR proportional gain 2	Setting range: 0.00-1.00	Factory default: 0.20
F6.06	ASR integral time 2	Setting range: 0.01-10.00s	Factory default: 0.50s
F6.07	ASR differential coefficient time 2	Setting range: 0.0-100.0s	Factory default: 0.0s
F6.08	ASR filter time 2	Setting range: 0.000-0.100s	Factory default: 0.005
F6.09	ASR switch frequency 2	Setting range: 0.00-50.00Hz	Factory default: 10.00Hz

ASR proportional gain and ASR integral time adjustment: System response will be quicker by increasing proportional gain. But if proportional gain is too big, there would be surge. System response will be quicker by

decreasing integral time. But if integral time is too short, there would be surge. Usually, adjust proportional gain firstly, and then adjust integral time.

Note: If ASR proportional gain is too big and ASR integral time is too small, over voltage may happen from system start to high speed quickly (without extra braking resistance or braking unit). It is caused by energy feedback reborn and it can be avoided by adjusting ASR proportional gain and ASR integral time.

ASR proportional gain and ASR integral time adjustment at high/low speed: Set ASR switching frequency [F6.04] and [F6.09] when there's quick response requirement for load at high/low speed.

Usually increasing proportional gain and decreasing integral time to improve response at low frequency running.

Adjusting steps: Select right switching frequency [F6.04] and [F6.09]. The first group of ASR parameter is valid when output frequency is under switch frequency 1 [F6.04]. The second group of ASR parameter is valid when output frequency is between switch frequency 1 [F6.04] and switch frequency 2 [F6.09]. Parameter linearly transits from switch frequency 1 [F6.04] to switch frequency 2 [F6.09] pro rate. Adjust ASR proportional gain 1 [F6.00] and ASR integral time 1 [F6.01] at low speed to ensure no surge and good response. Adjust ASR proportional gain 2 [F6.05] and ASR integral time 2 [F6.06] at high speed to ensure no surge and good response.

Usually, ASR differential coefficient time does not need to set. It is used to restrain sudden speed change. If it is too big, system surge comes easily.

F6.10	VC slip compensation coefficient	Setting range: 0-250%	Factory default 100%
-------	----------------------------------	-----------------------	----------------------

Used in occasion that needs quick response and high speed accuracy. Adjust this parameter properly, the system response can be improved and stable speed error can be eliminated.

F6.11	Speed control Max output torque	Setting range: 20.0-250.0%	Factory default 150.0%
-------	---------------------------------	----------------------------	------------------------

Used to adjust the upper limit of output torque in speed control mode and vector control. 100.00% corresponding to rated current.

F6.12	Constant power area torque compensation start frequency	Setting range: 100.0-500.0%	Factory default: 120.0%
F6.13	Constant power area torque compensation coefficient	Setting range: 0-100%	Factory default : 30%

Constant power area torque compensation start frequency: when setting inverter under VC control, switching to the torque constant power zone limit value of starting frequency; it's 100.00% corresponding to motor rated frequency.

Constant power area torque compensation coefficient: Set coefficient of torque compensation in constant power area. Appropriate reducing of the value can effectively prevent the motor from losing speed in weak magnetic field.

F6.14	Constant power area limit start frequency	Setting range: 100.0%-500.0%	Factory default : 200.0%
F6.15	Constant power area limit value	Setting range: 50-200%	Factory default : 120%

Constant power area limit start frequency: Set to switch to start frequency of torque limitation in constant power area under VC control. 100.00% is corresponding to motor rated frequency.

Constant power area limit value: Set limitation of torque in constant power area. It can effectively anti motor stall at weak magnetic area by reduce this limitation properly.

F6.16	Electrical loop D-axis proportional gain	Setting range: 0.1-10.0	Factory default: 1.0
F6.17	Electrical loop D-axis integral gain	Setting range: 0.1-10.0	Factory default: 1.0
F6.18	Electrical loop Q-axis proportional gain	Setting range: 0.1-10.0	Factory default: 1.0
F6.19	Electrical loop Q-axis integral gain	Setting range: 0.1-10.0	Factory default: 1.0

Set asynchronous machines, synchronous machine vector control PI current loop parameters. When VC, if there is instability like speed surge or current surge, the respective gain may be appropriately reduced to realize stability; at the same time, increasing gain helps to improve motor dynamic response.

F6.25	Vector boost gain	Setting range: 0-500%	Factory default: 100%
F6.26	Vector boost filter time	Setting range: 1-1000ms	Factory default: 20ms
F6.27	Vector slip compensation gain	Setting range: 0-500%	Factory default: 30%
F6.28	Vector slip compensation filter time	Setting range: 1-1000ms	Factory default: 100ms

When the asynchronous machine VC without PG (F0.00 = 1), the controller automatically compensates for voltage and frequency, [F6.25] and [F6.27], respectively voltage compensation gain and frequency compensation gain, the greater the gain, the more the compensation, the stronger the low-band carrier energy; [F6.26] and [F6.27] respectively compensation filter coefficients; when compensate instability occurs, appropriately increase filter time.

F6.31	MTPA gain	Setting range: 0.0-500.0%	Factory default: 0.0%
F6.32	MTPA filter time	Setting range: 0.0-999.9ms	Factory default: 100.0ms

MTPA function is optimizing the PMSM excitation strategies to achieve Max motor output / motor current; when the permanent magnet motor D, Q-axis inductance difference is large, adjust [F6.31] can significantly change the motor current under same load; adjust [F6.32] can improve the stability of the motor running.

F6.33-F6.35	Reserved		
-------------	----------	--	--

F6.36	PM demagnetization current limit	Setting range: 0-200%	Factory default: 0%
F6.37	PM weak feed forward gain	Setting range: 0-500%	Factory default: 100%
F6.38	PM weak magnetic proportional gain	Setting range: 0-9999	Factory default: 2000
F6.39	PM weak magnetic integral gain	Setting range: 0-9999	Factory default: 2000

When permanent magnet synchronous motors operating in high-performance mode, magnetic weakening and speed increasing can be implemented, the upper limit of magnetic currents is set by [F6.36], default 0 of [F6.36] is equivalent to close weakening function; [F6.37-F6.39] sets weakening control adjustable parameters, when weakening instability occurs in the process of weakening magnetic, adjust the set of parameters for commissioning.

F6.42	Open loop start mode	Setting range: 0-1	Factory default: 0
-------	----------------------	--------------------	--------------------

VC without PG synchronous machine has two startup modes: direct start and location detection start; in direct start mode, a certain degree of reverse rotating of the motor would occur. For relatively high start reversing occasions, position detection start can be selected to avoid start reversing, but it will bring start delay and noise

F6.45	Stabilizer proportional gain	Setting range: 0.1%-100.0%	Factory default: 20.0%
F6.46	Stabilizer proportional integral	Setting range: 1ms-5000ms	Factory default: 30ms

When selecting a permanent magnet motor VC without PG (F0.00 = 6), if there is a current or speed instability fluctuation, adjust [F6.45] and [F6.46] to improve and eliminate.

F6.47	Low-frequency current increasing extent	Setting range: 0.0% -200.0%	Factory default: 80.0%
F6.48	Low-frequency current increasing end frequency	Setting range: 0.00Hz-50.00Hz	Factory default: 50.00Hz

Permanent magnet motor VC without PG (F0.00 = 6), adjust **[F6.47]** to improve the motor starting torque and low-load capacity, but it will increase low-operating current.

F6.49	Low-frequency current D-axis gain	Setting range: 0.0-100.0	Factory default: 5.0
F6.50	Low-frequency current Q-axis gain	Setting range: 0.0-100.0	Factory default: 5.0

Permanent magnet motor VC without PG (F0.00 = 6) current control parameters; if there's abnormal vibration when the motor start with low frequency, the current gain can be reduced; if there is not enough torque, gain can be increased to improve start torque.

F6.51	Magnetic flow setting intensity	Setting range: 0-500%	Factory default: 100%
F6.52	Magnetic flow control proportional gain	Setting range: 0-9999	Factory default: 2000
F6.53	Magnetic flow control integral gain	Setting range: 0-9999	Factory default: 2000

Permanent magnet motor VC without PG (F0.00 = 6) current limit parameters, **[F6.51]** set the motor excitation intensity; adjusting the motor magnetic field strength can optimize and reduce the motor current under same load; if there is an output voltage instability or motor speed instability, it can be adjusted and improved by **[F6.53]** and **[F6.53]**.

F6.54	Over-current suppression point	Setting range: 0.0-250.0%	Factory default: 150.0%
F6.55	Over-current suppression gain	Setting range: 0-500%	Factory default: 100%
F6.56	Over-current suppression integral	Setting range: 1ms-1000ms	Factory default: 30ms

Permanent magnet motor VC without PG (F0.00 = 6) current limit parameters; when current increases to the upper limit of **[F6.54]**, when the load increases, the current increases; if current increases to the upper limit of **[F6.54]**, the drive automatically reduces the output frequency to reduce the power and make sure the control current does not exceed the upper limit; **[F6.55]** and **[F6.57]** are the current controller parameters, if there's over current and frequency decreasing instability, adjustment can be made to improve.

F6.57	DC pull-in time	Setting range: 1ms-9999ms	Factory default: 1000ms
-------	-----------------	---------------------------	-------------------------

Permanent magnet motor VC without PG (F0.00 = 6), if there is start failure or start instability, the parameter may be appropriately increased to solve the startup instability.

8.8 Torque Control Parameters

F7.00	Torque given channel selection	Setting range: 0-6	Factory default: 0
-------	--------------------------------	--------------------	--------------------

Using a relative value for torque setting; 100.0% corresponding to motor rated torque; Setting range from 0% to 200.0%, indicating that the inverter torque is 2 times the maximum rated torque.

0: Keyboard number given: by the function code [F7.01] given.

1: Keyboard potentiometer setting×F7.01: set by the keyboard potentiometer analog.

2: VS × F7.01: set by the VS terminal analog voltage input.

3: AI × F7.01: set by the AI terminal analog voltage or current input, voltage or current input can be selected via the control panel switch.

4: AS × F7.01: set by AS terminal current analog input.

5: PUL × F7.01: set by PUL terminal high-speed pulse.

6:RS485 communication given×F7.01: set by the RS485 serial communication; communication address 0x3005 / 0x2005.

Note: 1-6 above 100% correspond to the function code [F7.01]:

F7.01	Torque keyboard number setting	Setting range: 0-200.0%	Factory default: 100.0%
-------	--------------------------------	-------------------------	-------------------------

When the function code [F7.00] = 0, the torque setting point is given by the function code [F7.01].

F7.02	Torque direction selecting	Setting range: 0000-0011	Factory default: 00
-------	----------------------------	--------------------------	---------------------

LED "0" digit: torque direction setting:

0: torque direction forward inverter runs forward

1: torque direction reverse inverter runs reversely

LED "00" digit: torque direction change setting:

0: allow torque direction change inverter runs in one direction

1: no direction change inverter runs in both directions

Note: When torque control the direction would not be impacted by the F0.16 setting, and the keyboard FWD or REV can keep the inverter starting in one direction.

F7.03	Output torque upper limit	Setting range: F7.04-200.0%	Factory default: 150.0%
F7.04	Output torque lower limit	Setting range: 0-F7.03	Factory default: 0%

Output torque upper limit: set the upper limit of output torque;

Output torque lower limit: set the lower limit of output torque;

F7.05	Torque control FWD speed limit selecting	Setting range: 0-8	Factory default: 0
-------	--	--------------------	--------------------

Used to set the Max FWD operating frequency limit of inverter in torque control mode;

In torque control mode, if the load torque is less than the output torque of the motor, the motor speed will go up, and in order to prevent emergence such as mechanical systems coaster accidents, the Max motor speed must be limited in torque control mode.

0: **Keyboard number given:** by the function code [F7.07] given.

1: **Keyboard potentiometer setting×F7.07:** set by the keyboard potentiometer analog.

2: VS × F7.07: set by the VS terminal analog voltage input.

3: AI × F7.07: set by the AI terminal analog voltage or current input, voltage or current input can be selected via the

control panel switch.

4: AS × F7.07: set by AS terminal current analog input.

5: PUL × F7.07: set by PUL terminal high-speed pulse.

6:RS485 communication given×F7.07: set by the RS485 serial communication; communication address 0x3006 / 0x2006.

Note: 1-6 above 100% correspond to the function code [F7.07]:

F7.06	Torque control REV speed limit selecting	Setting range: 0-8	Factory default: 0
-------	--	--------------------	--------------------

[F7.06] and [F7.05] are the same, [F7.06] is for reverse speed limited, the corresponding given function code is [F7.08].

F7.07	Torque control FWD Max speed limit selecting	Setting range: 0.00-upper frequency limit	Factory default: 50.00Hz
F7.08	Torque control REV Max speed limit selecting	Setting range: 0.00-upper frequency limit	Factory default: 50.00Hz

When the function code [F7.05], [F7.06] is set to 0, the Max speed limit would be set by [F7.07], [F7.08].

F7.09	Speed/torque switching delay	Setting range: 0.00-10.00s	Factory default: 0.01s
-------	------------------------------	----------------------------	------------------------

When switching speed / torque mode via terminals X1 - X7 or [F0.01], switching can be done after the delay time set by [F7.09].

F7.10	Torque ACC time	Setting range: 0.00-10.00s	Factory default: 0.01s
F7.11	Torque DEC time	Setting range: 0.00-10.00s	Factory default: 0.01s

In torque operating mode, the difference between motor output torque and load torque determines the speed change rate of the motor and load. Thus, the rapid changes in motor speed may cause noise or mechanical overshoot and other faults; the motor speed can be smoothly changed by setting the torque control acceleration and deceleration time. Torque deceleration time is twice the nominal torque as a reference (200%).

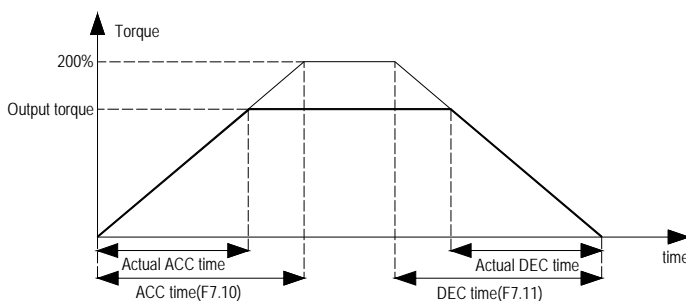

Torque ACC/DEC chart

F7.12	FWD/REV torque dead time	Setting range: 0.00-650.00s	Factory default: 0.00s
-------	--------------------------	-----------------------------	------------------------

For torque operation mode, when direction changes in transition time waiting at 0.0Hz; this function code is similar with [F1.25].

8.9 V/F Control Parameters

F8.00	V/F curve selection	Setting range:0-4	Factory default 0
-------	---------------------	-------------------	-------------------

V/F curve selection: used to select the V/F curve types to meet different load requirements.

0: linear V/F curve

1-9: 1.1-1.9 respectively VF power curve, as shown below;

10: VF square curve;

11: Custom VF curve; see [F8.01-F8.10];

VF default linear curve for most common situations; multi-idempotent curve and square VF curve are generally used for VF fans or pumps to reduce the high-frequency current to achieve energy savings.

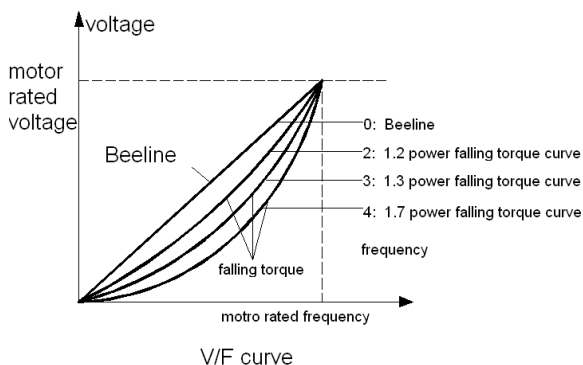

Note: multi-idempotent curve and square VF curve are calculated from the initial frequency set in F8.11, see F8.15

F8.01	Self-setting voltage V1	Setting range: 0.0-100.0%	Factory default 3.0%
F8.02	Self-setting frequency F1	Setting range: 0.00-max frequency	Factory default 1.00Hz
F8.03	Self-setting voltage V2	Setting range: 0.0-100.0%	Factory default 28.0%
F8.04	Self-setting frequency F2	Setting range: 0.00-max frequency	Factory default 10.00Hz
F8.05	Self-setting voltage V3	Setting range: 0.0-100.0%	Factory default 55.0%
F8.06	Self-setting frequency F3	Setting range: 0.00-max frequency	Factory default 25.00Hz
F8.07	Self-setting voltage V4	Setting range: 0.0-100.0%	Factory default 78.0%
F8.08	Self-setting frequency F4	Setting range: 0.00-max frequency	Factory default 37.50Hz
F8.09	Self-setting voltage V5	Setting range: 0.0-100.0%	Factory default 100.0%
F8.10	Self-setting frequency F5	Setting range: 0.00-max frequency	Factory default 50.00Hz

Self-setting V/F curve: Users set the $1^{\text{st}}/2^{\text{nd}}/3^{\text{rd}}/4^{\text{th}}/5^{\text{th}}$ voltage ratio of V/F curve corresponding to F1/F2/F3/F4/F5 frequency based on rated output voltage 100%. Users set the $1^{\text{st}}/2^{\text{nd}}/3^{\text{rd}}/4^{\text{th}}/5^{\text{th}}$ frequency of V/F curve corresponding to V1/V2/V3/V4/V5.

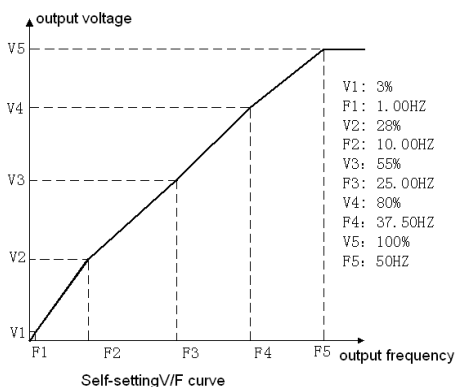

Must meet: $0 \leq F1 \leq F2 \leq F3 \leq F4 \leq F5 \leq \text{max frequency}$, $0 \leq V1 \leq V2 \leq V3 \leq V4 \leq V5 \leq 100.0\%$

V1, V2, V3, V4, V5 is based on motor rated voltage.

F8.11	Output voltage percentage	Setting range: 25-100%	Factory default :100%
-------	---------------------------	------------------------	-----------------------

Output voltage adjustment coefficient adjusts output voltage of inverter to meet different V/F requirement.

F8.12	Torque boost	Setting range: 0.1-30.0%	Factory default :Accord model
F8.13	Torque boost cut-off frequency	Setting range: 0.0-100.0%	Factory default :20.0%

Torque boost: Improve low frequency torque trait by voltage compensation. Please set it rightly. If too high, motor maybe happens over excitation at low frequency running, over heat when long time, even over current protection or can't start normally.

Note: when [F8.00] is 1, [F8.12] is invalid.

Torque boost cut-off frequency: Set torque boost valid range. When output frequency exceeds this value, torque boost function stop. 100% is corresponding to motor rated frequency.

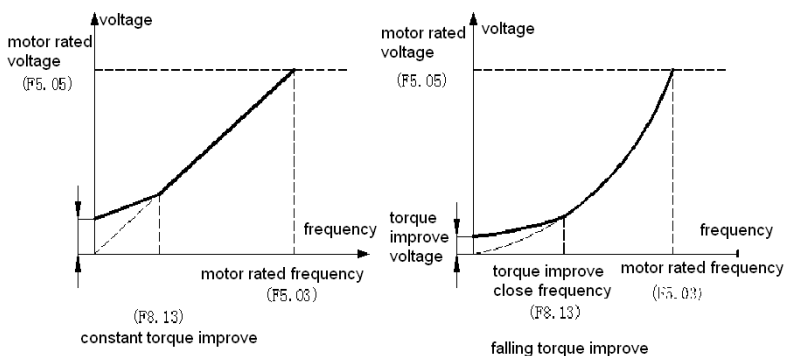

F8.14	V/F slip compensation	Setting range:0.0-200.0%	Factory default:0.0%
-------	-----------------------	--------------------------	----------------------

This function allows the output frequency change with motor load automatically adjusted within the set range; dynamic compensation to the slip frequency of the motor, so that the motor remains substantially constant speed, effectively reducing the impact of load changes on the motor speed

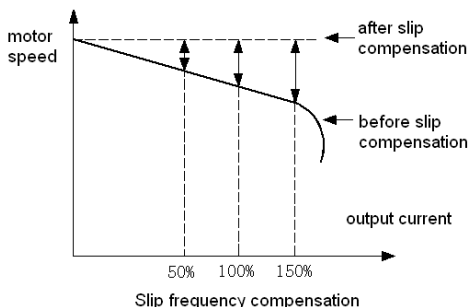

If automatic torque function is used, the low-torque characteristics of the inverter can be significantly improved. 100.0% slip frequency compensation corresponds to the motor rated slip; it may cause the motor speed exceeds setting value when the compensation value is set too large.

F8.15	Auto energy save selection	Setting range: 0-1	Factory default: 0
-------	----------------------------	--------------------	--------------------

Set starting frequency of multi-idempotent curve and square VF curve, under the initial frequency is straight line VF to ensure adequate low frequency torque;

F8.16	Lower frequency limit of energy save running	Setting range: 0.0-500.0%	Factory default: 25.0%
F8.17	Energy save voltage down time	Setting range: 0.01-50.00s	Factory default :10.00s

When the motor control mode F0.00 = 1 or 3 or 4, there may be unstable motor current and motor speed surge, which is an electrical and mechanical low-frequency resonance. Adjusting the [F8.16] and [F8.17] can suppress low-frequency resonance, but too much suppression gain can lead to additional stability problems.

F8.18	Energy save voltage lower limit	Setting range: 20.0-100.0%	Factory default: 50.0%
F8.19	ASR(VF) proportion gain1	Setting range:0.0-100.00	Factory default: 1.00
F8.20	ASR(VF) integral time 1	Setting range:0.01-10.00s	Factory default: 0.50s

VF control of linear asynchronous motors, motor current increases as the load increases, over current suppression gain function limits the maximum motor current, when the current reaches F8.30 * inverter rated current, the output frequency is automatically reduced to limit the motor current within the set value of [F8.18]; [F8.19] and [F8.20] are the over current suppression control parameters, adjusting these two parameters can optimize and improve the over current suppression effect.

F8.21-F8.22	Reserved
-------------	----------

F8.23	Auto energy-saving selection	Setting range: 0-1	Factory default: 0
F8.24	Lower frequency limit of energy-saving	Setting range: 0.0-500.0%	Factory default: 25.0%
F8.25	Energy-saving voltage down time	Setting range: 0.01-50.00s	Factory default: 10.00s
F8.26	Energy-saving lower limit	Setting range: 20.0-100.0%	Factory default: 50.0%

Auto energy-saving selection:

0: no operation

1: auto energy-saving

In operation, the inverter can automatically calculate the best output voltage in the load condition to save power. The power saving is working by reducing the output voltage and increasing motor efficiency.

Lower frequency limit of energy-saving running: When output frequency is lower than this value, auto energy save function will close. 100% corresponds to motor rated frequency.

Energy-saving time voltage down time: It is the time for the output voltage changing from rated voltage to 0V when meeting auto energy save conditions.

Energy-saving voltage down lower limit: Set lower limitation of voltage in energy-saving running condition. 100% corresponds to motor rated frequency.

8.10 Malfunction and Protection Parameters

FA.00	OV suppression point	Setting range: 110%-150%	Factory default: 135%
FA.01	OV suppression gain	Setting range: 0-500%	Factory default: 100%
FA.02	OV suppression filter time	Setting range: 1-1000ms	Factory default: 20ms

When bus voltage reaches or exceeds $[FA.00] \times$ rated bus voltage when inverter running, the inverter will automatically adjust the operating frequency and suppress the bus voltage from increasing, thus ensuring there's no OV protection due to high bus voltage. Adjusting $[FA.01]$ and $[FA.02]$ can improve OV suppression effect; set $[FA.01]$ is equivalent to 0:00 cut-off OV suppression function and OV suppression is valid for any motor control mode.

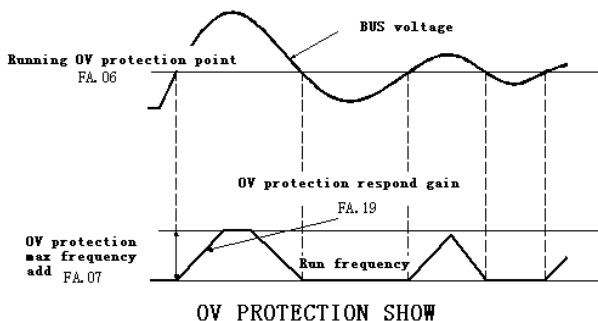

FA.03	Reserved
-------	----------

FA.04	Fan control	Setting range: 0-2	Factory default: 1
-------	-------------	--------------------	--------------------

Select fan run mode.

0: Fan run after electrify No matter temperature of module is high or not, fan runs when inverter power on.

1: Fan stop related to temperature Work when running. When inverter stops, fan runs when module temperature is over 50 degree and stops 30 seconds after module temperature is lower than standard. When inverter runs, fan runs.

2: Fan stop when machine stop, run related to temperature When inverter runs, fan runs when module temperature is over 50 degree and stops 30seconds after module temperature is lower than standard. When inverter stops, fan stops.

Note: This function can prolong fan life.

FA.05-FA.06	Reserved		
-------------	----------	--	--

FA.07	Running OV protection point	Setting range:100-150%	Factory default: 115%
-------	-----------------------------	------------------------	-----------------------

Inverter DC bus rated voltage=inverter input rated voltage*1.414

DEC OV protection: Set OV protection point when DEC. Only valid when [FA.01] LED "0" digit is 1.

Running OV protection point: Set OV protection point when ACC or running at constant speed. Only valid when [FA.01] LED "0" digit is 1.

FA.07	magnetic flow braking gain	Setting range: 0-500%	Factory default: 100%
-------	----------------------------	-----------------------	-----------------------

Magnetic flow braking is a brake control method of induction motor, valid in induction motor control mode; set [FA.07] to 0 to disable this function. Appropriately increasing [FA.07] can significantly improve the deceleration braking effect;

FA.08	Energy braking act voltage	Setting range: 115.0-140.0%	Factory default: 120.0%
-------	----------------------------	-----------------------------	-------------------------

FA.09	Reserved		
-------	----------	--	--

Energy braking action voltage: Inverter energy braking begins when DC bus voltage rises and exceeds (rated voltage × FA.08). It is only valid for inverter with inner braking parts. Inverters under AC100-T3-018G have build in braking parts. AC100-S2-3R7G and inverters under than that with 220V input have built-in braking parts. All inverters do not have braking resistance. If need energy braking, please use optional resistance.

Note: Otherwise overvoltage suppression is possible to suppress the rise of the bus voltage, thus the brake action point can't be reached.

FA.10	Bus under-voltage protection	Setting range:50.0-100.0%	Factory default: 60.0%
-------	------------------------------	---------------------------	------------------------

This parameter specifies the lower voltage allowed by bus voltage during operation, for some low power occasions, appropriate under-voltage protection level can be reduced to ensure the normal working of the inverter.

Note: When the grid voltage is too low, the motor output torque will decrease. For constant power load and constant torque load, low grid voltage will increase the frequency converter input and output current, thereby reducing the reliability of the inverter operation.

FA.11	Output power correction factor	Setting range: 0-200%	Factory default: 20%
FA.12	Power display dimension selection	Setting range: 0-1	Factory default: 0

FA.11 is used for correcting the inverter output power showed in C-10, FA.12 can choose the unit of displaying the power;

0: 0.1% displays the output power is 100%, 100% corresponds to the motor rated power;

1: 0.1kw displays actual output power value;

FA.13	Speed tracking wait time	0.00-60.00s	Factory default: 1.00
FA.14	Speed tracking frequency gain	0.00Hz - 50.00Hz	Factory default: 10.00Hz
FA.15	Speed tracking current gain	0.50 - 1.50	Factory default: 1.00

Speed tracking parameters;

FA.17	Hardware current and voltage protection	Setting range: 100-250%	Factory default: 160%
-------	---	-------------------------	-----------------------

LED "0" digit: cycle-by-cycle current limit: cycle-by-cycle current limit can limit current rise to a certain extent by hardware protection so that the current does not exceed the protection value of the inverter and avoid skipping flow fault shutdown.

0: Close

1: Open

LED "00" digit: hardware over-voltage protection: increasing bus voltage protection by hardware, which is a backup and a supplement for software protection, improving equipment reliability

0: Close

1: Open

LED "000" digit: SC disturbing filter time:

0 - F (set to 0 Close SC Protection)

LED "0000" digit: Current disturbing suppression:

0: Close

1: Open

FA.18	Power-to-ground short-circuit detection	Setting range: 0.00-650.00s	Factory default: 10.00s
-------	---	-----------------------------	-------------------------

Power-to-ground short-circuit detection detects the motor insulation when power on. If the motor insulation damage is shorted to ground, the inverter will detect and report a short to ground fault.

0: Close

1: Open

FA.19	Phase loss protection	Setting range: 0.0-10.00	Factory default: 0.50
-------	-----------------------	--------------------------	-----------------------

LED "0" digit: output phase protection: Motor drive connected occurrence will be reported missing output phase fault E.OLF.

0: Close

1: Open

LED "00" digit: input phase protection: Occurrence of a grid phase inverter will report missing input phase failure E.ILF.

0: Close

1: Open

LED "000" digit: Off load protection: The inverter output off load fault when motor connecting load suddenly decreases.

0: Close

1: Open

FA.20	Motor overload pre-alarm coefficient	Setting range: 20.0-250.0%	Factory default: 80.0%
FA.21	Motor overload protective coefficient	Setting range: 20.0-250.0%	Factory default: 100.0%

Long term motor overload would produce serious heat, [FA.21] sets the coefficient of load motor overload protection or thermal protection; the motor overload protection and motor current curve was inverse, protection curve when FA.21 = 100.0% is shown as follows:

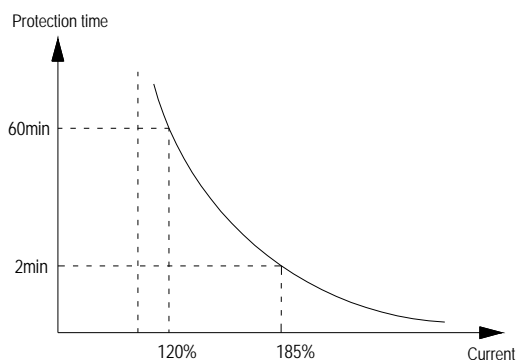

So increasing [FA.21] can improve motor overload; overload pre alarm coefficient can be set by [FA.21], when the motor had reached the degree of overload factor [FA.21] setting, the inverter outputs alarm by terminal, for details please see Y terminal function.

FA.22	Malfunction auto-reset times	Setting range: 0-5	Factory default: 0
FA.23	Malfunction auto-reset interval	Setting range: 0.1-100.0s	Factory default: 1.0s

Malfunction auto-reset times:

0: Off No automatic reset function; manual reset.

1-5: On 1-5 is the automatic reset times;

The inverter would fail or stop during operation due to load fluctuations, voltage fluctuations and other factors. At this time in order to ensure continuity of system operation, automatic resets of inverter for overload, over current, system abnormalities, overvoltage, under voltage faults are allowed. The inverter would restart by speed tracking in the process of self recovery. If the inverter can't restart within the set times, stop output for fault protection; Fault recovery times can be set up to five times, after 10 minutes running the fault recovery times would be re-recorded and the times before is automatically cleared. Consecutive failures of restarting might cause harm, so the proposed fault recovery time is 1;

Output terminal can be selected to act or not act in automatic reset process. Details refer to [F2.29-F2.31].

Malfunction auto-reset interval: It defines waiting time before resetting after fault.

Note: 1: Only valid for fault of OL, OC, system abnormality, under voltage. Not valid for other faults.

2: Can't reset before dealing with malfunction.

Attention: Please use this function carefully in occasions that can't start with load, or that needs alarm immediately when there's no output.

FA.24	reserved
-------	----------

FA.25	Malfunction types	Please see malfunction code table	--
FA.26	Malfunction running frequency	0.00-max frequency	--
FA.27	Malfunction output voltage	0-1500V	--
FA.28	Malfunction output current	0.1-2000.0A	--
FA.29	Malfunction bus voltage	0-3000V	--
FA.30	Malfunction module temperature	0-100℃	--
FA.31	Malfunction machine state	LED "0" digit: run direction 0: FWD 1: REV LED "00" digit: run state 0:stop 1:stable speed 2:ACC 3:DEC LED "000" digit: reserved LED "0000" digit: reserved	--
FA.32	Malfunction input terminal state	See input terminal chart	--
FA.33	Malfunction output terminal state	See output terminal chart	--
FA.34	The last 1 malfunction types	Please see malfunction code table	--
FA.35	The last 1 malfunction running frequency	0.00-max frequency	--
FA.36	The last 1 malfunction output voltage	0-1500V	--
FA.37	The last 1 malfunction output current	0.1-2000.0A	--
FA.38	The last 1 malfunction bus voltage	0-3000V	--
FA.39	The last 1 malfunction module temperature	0-100℃	--
FA.40	The last 1 machine state	LED "0" digit: run direction 0: FWD 1: REV LED "00" digit: run state 0:stop 1:stable speed 2:ACC 3:DEC LED "000" digit: reserved	--

		LED "0000" digit: reserved	
FA.41	The last 1 malfunction input terminal state	See input terminal chart	--
FA.42	The last 1 malfunction output terminal state	See output terminal chart	--
FA.43	The last 2 malfunction types	Please see malfunction code table	--
FA.44	The last 3 malfunction types	Please see malfunction code table	--

Note: Malfunction records can be cleared by [F0.19]. See [F0.19] details.

8.11 PID Parameters

PID control is a common method used in process control. Through a series of proportional, integral and derivative calculations on the value difference between the controlled object feedback and inverter PID feedback to adjust the output frequency of the inverter, which forms the negative feedback PID regulation to stabilize the controlled object within the PID given value.

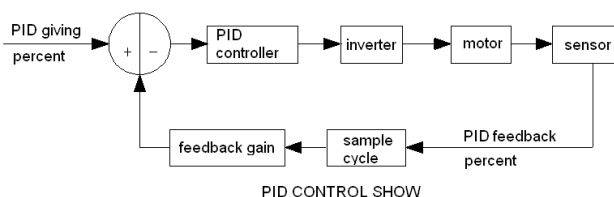

Fb.00	PID controller given signal source	Setting range: 0-9	Factory default: 0
-------	------------------------------------	--------------------	--------------------

Set the input channel of PID controller given signal.

0: Keyboard number PID given: Decided by [Fb.01] setting.

1: Keyboard potentiometer: given by keyboard potentiometer

2: Terminal VS voltage analog: given by terminal VS voltage analog

3: Terminal AI analog: given by terminal AI analog

4: Terminal AS current analog: given by terminal AS current analog

5: Terminal PUL pulse signal: given by terminal PUL pulse signal

6: RS485 communication: given by RS485 communication: communication address is 0x3008/0x2008

7: Optional card: given by optional card; see optional card manual

8: Terminal selection: given by multifunctional input terminal combination set by [F2.00-F2.07].

Terminal switch table:

Terminal 3	Terminal 2	Terminal 1	PID giving terminal switch selection
OFF	OFF	OFF	Keyboard number give PID
OFF	OFF	ON	Keyboard potentiometer
OFF	ON	OFF	Terminal VS voltage analog
OFF	ON	ON	Terminal AI analog
ON	OFF	OFF	Terminal AS current analog
ON	OFF	ON	Terminal PUL pulse signal
ON	ON	OFF	RS485 communication
ON	ON	ON	Optional card

Any doubt please see "FC" parameter group which is about multispeed time sequence.

Fb.01	Keyboard number give PID	Setting range: 0.00-100.0%	Factory default: 50.0%
-------	--------------------------	----------------------------	------------------------

This function is valid only when [Fb.00]/[Fb.02] is set as keyboard number given/feedback. It is based on feedback signal max range [Fb.04]. After this parameter is changed, PID given in monitor object is modified automatically at the same time.

If [Fb.04] LED "0" is set as 3, this value can be modified by UP/DW key. Whether save the modification is decided by [F4.04] LED "00" digit.

Fb.02	PID feedback signal source	Setting range:0-8	Factory default:2
-------	----------------------------	-------------------	-------------------

Set PID controller feedback signal input channel:

0: Keyboard number PID feedback: PID feedback channel decided by [Fb.01].

1: Keyboard potentiometer feedback: Keyboard potentiometer feedback channel

2: Terminal VS voltage analog feedback: Terminal VS voltage analog feedback channel

3: Terminal AI voltage analog feedback: Terminal AI voltage analog feedback channel

4: Terminal AS current analog feedback: Terminal AS current analog feedback channel

5: Terminal PUL pulse signal feedback: Terminal PUL pulse signal feedback channel

6:RS485 communication feedback: PID feedback channel decided by RS485.Communication address is 0x3009/0x2009.

7: Optional card: optional card PID feedback channel; see optional card manual

8: Terminal selection: PID feedback channel decided by multifunction input terminal combination. Multifunction input terminal is set by [F2.00-F2.07].

Terminal switch table:

Terminal 3	Terminal 2	Terminal 1	PID giving terminal switch selection
OFF	OFF	OFF	Keyboard number give PID
OFF	OFF	ON	Keyboard potentiometer
OFF	ON	OFF	Terminal VS voltage analog
OFF	ON	ON	Terminal AI analog
ON	OFF	OFF	Terminal AS current analog
ON	OFF	ON	Terminal PUL pulse signal
ON	ON	OFF	RS485 communication
ON	ON	ON	Optional card

Any doubt please see "FC" parameter group which is about multispeed time sequence.

Note: PID controller given signal source and PID controller feedback signal source can't be the same. Otherwise PID can't work normally.

Fb.03	Feedback signal gain	Setting range: 0.00-10.00	Factory default:1.00
-------	----------------------	---------------------------	----------------------

It is used to magnify or reduce feedback channel input signal.

Fb.04	Feedback signal max measuring range	Setting range: 0-100.0	Factory default:100.0
-------	-------------------------------------	------------------------	-----------------------

It is used to revise the display data of PID given and PID feedback.

$$\text{Display data} = \frac{\text{give/feedback signal-lowest limit value for this channel}}{\text{highest limit value for this channel-lowest limit value for this channel}} \times \frac{\text{max sensor measuring range}}{\text{measuring range}}$$

For example: Under pressure control, when it is set as sensor max measuring range, it displays actual pressure.

If VS is feedback signal input channel, when VS highest limit is set as 9V and lower limit 0.5V, feedback voltage is 4.5V, and sensor measuring range is 20mpa.

$$\text{Display value} = (4.5-0.5) \times 20/(9-0.5) = 9.4\text{mpa}$$

Fb.05	PID control selections	Setting range: 0000-0011	Factory default: 0100
-------	------------------------	--------------------------	-----------------------

LED "0" digit: feedback feature selection

0: Positive feature: suitable for occasions where PID feedback is bigger than PID given and requires output frequency reducing to balance PID. Such as constant pressure water supply, gas supply, take-up tension control.

1: Negative feature: suitable for occasions where PID feedback is bigger than PID given and requires output frequency rising to balance PID. Such as constant temperature control, pay-off tension control.

LED "00" digit: PID adjustment direction selection

0: REV forbid

1: REV permit

Inverter control output frequency after given signal and feedback signal calculation according to PID control mode setting when receiving the run order. If REV forbid ([F0.07] LED "00" digit is 0 frequency control direction invalid or [F0.16] is 2 REV forbid), inverter outputs 0.00Hz. If REV permit, inverter will change output direction, motor REV.

LED "000" digit: align selection

When PID setting is not at the centre point of 50%, error range of PID feedback and PID setting is non-symmetry state.

0: Not centre align: No correcting error.

1: Centre align: Correcting error

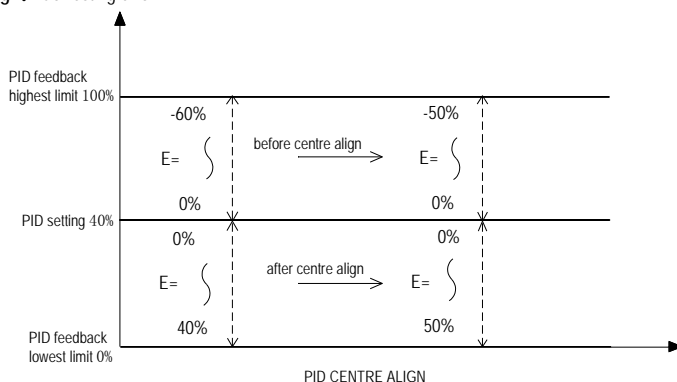

LED "0000" digit: reserved

Fb.06	PID preset frequency	Setting range: 0.00-100.0%	Factory default: 100.00Hz
Fb.07	PID preset frequency running time	Setting range: 0.0-6500.0s	Factory default: 0.0s

When it defines as PID start running, frequency ACC to PID pre-set frequency [Fb.06] according to ACC time 1. After setting [Fb.07] time, it runs as PID closed loop trait.

Tip: When PID is used for frequency source given, [F0.03 = 8] preset outputs 100.0% corresponding maximum output frequency; when PID is used for the frequency voltage separation and outputs voltage source; [F0.26 = 5] preset outputs 100.0% corresponding motor rated voltage.

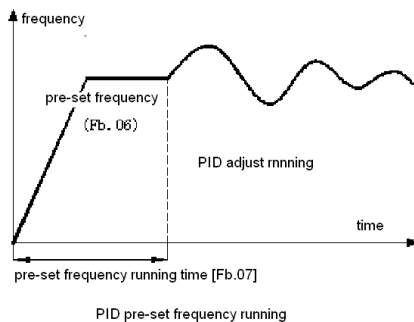

Fb.08	Proportional gain: P	Setting range: 0.00-100.00	Factory default: 1.00
Fb.09	Integral time: I	Setting range: 0.01-10.00s	Factory default: 0.10s
Fb.10	Differential gain : D	Setting range: 0.00-10.00s	Factory default: 0.00s

The parameter value controlled by PID should be set according to the actual characteristics of the system.

Proportional gain P: It decides the impact of P act to bias. Response is quicker when gain is bigger. But there will be surge when it is too big. Response is slower when gain is smaller.

Integral time I: It decides the effect of act I. Response is slower and control ability for out disturbance is weaker when integral time increases. Response is quicker when integral time is small. But there will be surge if it is too small.

Differential gain D: When bias of PID feedback and PID given is changing, it adjusts change rate of output and bias pro rata. It is only related to direction and size of bias change, not related to direction and size of bias itself. Be careful when using since it easily magnifies the disturbance, especially high changing frequency.

Fb.11	Sampling period	Setting range: 0.01-100.00s	Factory default: 0.10s
-------	-----------------	-----------------------------	------------------------

It is only valid for PID feedback sampling period. Adjust and calculate once in every sampling period. Response is quicker when sampling period is smaller.

Fb.12	PID control deviation limit	Setting range: 0.0-100.0%	Factory default: 0.0%
-------	-----------------------------	---------------------------	-----------------------

When feedback is in this range, PID adjustment stops. Output does not change; the reasonable use of the feature helps coordinate the contradiction between system output accuracy and stability.

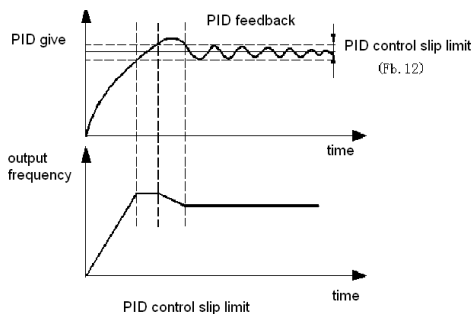

Fb.13	Reserved		
-------	----------	--	--

Fb.14	Feedback wire break detection time	Setting range: 0.0-120.0s	Factory default: 1.0s
Fb.15	Feedback wire break action selection	Setting range: 0-3	Factory default: 0
Fb.16	Wire break alarm upper limit	Setting range: 0.0-100.0%	Factory default: 100.0%
Fb.17	Wire break alarm lower limit	Setting range: 0.0-100.0%	Factory default: 0.0%

When PID given frequency and inverter is running, if feedback signal which is bigger than [Fb.16] or smaller than [Fb.17] is detected and keeps for [Fb.14] delay time, it is considered as sensor wire break.

Feedback wire-break action selections

0: Go on PID operation without alarm: no wire-break detection when invalid

1: Stop and alarm malfunction: When the inverter detects a sensor break, immediately block output, motor free stop and report E.PID fault.

2: Go on PID operation and output alarm signal: When the inverter detects a sensor break, still run by the PID regulation, but the keyboard displays E.PID fault and flashes.

3: Run the current frequency and output alarm signal: When the inverter detects a sensor break, maintain constant output frequency before the fault, but the keyboard displays E.PID fault and flashes.

Wire break alarm upper limit: when feedback signal is over alarm upper limit for time [Fb.14], it is considered as sensor wire break.

Wire break alarm lower limit: when feedback signal is under alarm upper limit for time [Fb.14], it is considered as sensor wire break.

8.12 Multi-speed, PLC Function and Swing Frequency Parameters

FC.00	PLC multi-speed 1	Setting range: 0.00-320.00Hz	Factory default: 10.00Hz
FC.01	PLC multi-speed 2	Setting range: 0.00-320.00Hz	Factory default: 20.00 Hz
FC.02	PLC multi-speed 3	Setting range: 0.00-320.00Hz	Factory default: 30.00 Hz
FC.03	PLC multi-speed 4	Setting range: 0.00-320.00Hz	Factory default: 40.00 Hz
FC.04	PLC multi-speed 5	Setting range: 0.00-320.00Hz	Factory default: 50.00 Hz
FC.05	PLC multi-speed 6	Setting range: 0.00-320.00Hz	Factory default: 40.00 Hz
FC.06	PLC multi-speed 7	Setting range: 0.00-320.00Hz	Factory default: 30.00 Hz
FC.07	PLC multi-speed 8	Setting range: 0.00-320.00Hz	Factory default: 20.00 Hz
FC.08	PLC multi-speed 9	Setting range: 0.00-320.00Hz	Factory default: 10.00 Hz
FC.09	PLC multi-speed 10	Setting range: 0.00-320.00Hz	Factory default: 20.00 Hz
FC.10	PLC multi-speed 11	Setting range: 0.00-320.00Hz	Factory default: 30.00 Hz
FC.11	PLC multi-speed 12	Setting range: 0.00-320.00Hz	Factory default: 40.00 Hz
FC.12	PLC multi-speed 13	Setting range: 0.00-320.00Hz	Factory default: 50.00 Hz
FC.13	PLC multi-speed 14	Setting range: 0.00-320.00Hz	Factory default: 40.00 Hz
FC.14	PLC multi-speed 15	Setting range: 0.00-320.00Hz	Factory default: 30.00 Hz

It sets run frequency of 15 steps in PLC and multistep control.

Multi-speed control has priority only after JOG. When in multi-speed control, 4 multifunction input terminals are needed to set as control terminals. Set details refer to [F2.00-F2.06].

Running speed of inverter is decided by the ON/OFF state of 4 control terminals and COM. The running and direction is controlled by running signal and direction given by [F0.02]. ACC/DEC time default is ACC/DEC time 1 [F0.14], [F0.15]. ACC/DEC time can also be selected by ACC/DEC time selection terminal set by [F2.00-F2.06].

Multi speed terminal 4	Multi speed terminal 3	Multi speed terminal 2	Multi speed terminal 1	terminal speed
OFF	OFF	OFF	ON	1X [FC.00]
OFF	OFF	ON	OFF	2X [FC.01]
OFF	OFF	ON	ON	3X [FC.02]
OFF	ON	OFF	OFF	4X [FC.03]
OFF	ON	OFF	ON	5X [FC.04]
OFF	ON	ON	OFF	6X [FC.05]
OFF	ON	ON	ON	7X [FC.06]
ON	OFF	OFF	OFF	8X [FC.07]
ON	OFF	OFF	ON	9X [FC.08]
ON	OFF	ON	OFF	10X [FC.09]
ON	OFF	ON	ON	11X [FC.10]
ON	ON	OFF	OFF	12X [FC.11]
ON	ON	OFF	ON	13X [FC.12]
ON	ON	ON	OFF	14X [FC.13]
ON	ON	ON	ON	15X [FC.14]

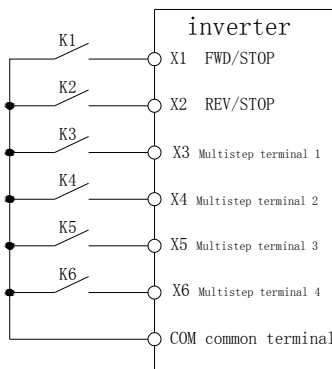

Terminal connection

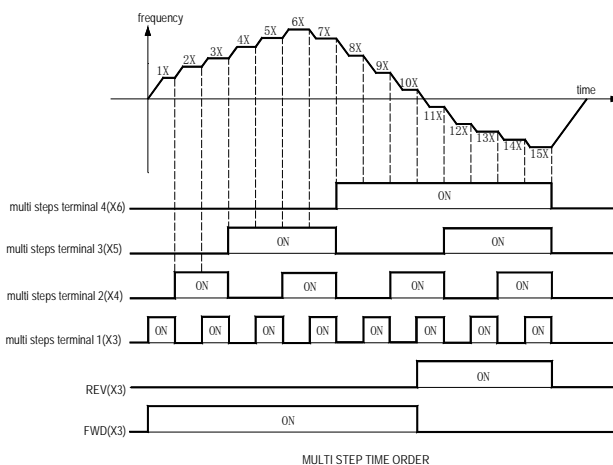

MULTI STEP TIME ORDER

FC.15	PLC running mode selections	Setting range: 0000-2212	Factory default: 0000
-------	-----------------------------	--------------------------	-----------------------

LED "0" digit: cycle mode

0: Stop after single cycle When receiving order, inverter runs from the first step, time unit is set by [FC.15] LED "00" digit. Running time is set by [FC.16-FC.30]. Running direction and ACC/DEC time are selected by [FC.31-FC.45]. Turn to next speed when running time is over, run time, direction, ACC/DEC time of every step can be set separately. Inverter outputs 0 Hz when finishing 15 steps running. If one step running time is 0, it will skip this step.

1: Continuous cycles Inverter would not stop and run at the latest speed when finished 15 steps running. Time unit is set by [FC.15] LED "00" digit. Run time is set by [FC.16-FC.30]. Run direction and ACC/DEC time is selected by [FC.31-FC.45].

2: Keep final value after single cycle Inverter back to 1st speed after finishing 15 steps running. Time unit is set by [FC.15] LED "00" digit. Running time is set by parameter [FC.16-FC.30]. Running direction and ACC/DEC time are selected by [FC.31-FC.45].

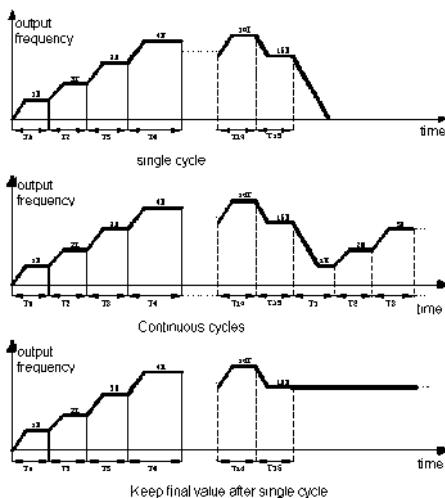

LED"00"digit: Time unit

0: second

1: minute

2: hour

LED"000"digit: Power down storage mode

0: no storage

1: storage

This parameter is defined as when the selection process is running, the inverter power whether to store the current state of the running program (running stages, the remaining time of this stage, deceleration and direction of travel, etc.). If you choose power down storage, the "000"digit of [FC.15] defines the way power is restored of the next running. To ensure sustainable state of inverter after power recovery, the parameter should be set as "1".

LED"0000"digit: Start-up mode

0: Restart from the 1st step

1: Restart from the step when stop

2: Continue from the time when stop

Set restart mode when stop for some reasons (stop, fault, power off and so on).

Choosing 0: Restart from the 1st step

Choosing 1: Restart from the step when stop

Choosing 2: Continue from the time when stop

Note: Output frequency is limited by upper/lower limit frequency. When frequency is lower than lower limit frequency, it runs as [F0.13] lower limit frequency mode.

FC.16	PLC 1st step running time	Setting range: 0.0-6500.0(s/m/h)	Factory default: 10.0
FC.17	PLC 2nd step running time	Setting range: 0.0-6500.0(s/m/h)	Factory default: 10.0
FC.18	PLC 3rd step running time	Setting range: 0.0-6500.0(s/m/h)	Factory default: 10.0
FC.19	PLC 4th step running time	Setting range: 0.0-6500.0(s/m/h)	Factory default: 10.0
FC.20	PLC 5th step running time	Setting range: 0.0-6500.0(s/m/h)	Factory default: 10.0
FC.21	PLC 6th step running time	Setting range: 0.0-6500.0(s/m/h)	Factory default: 10.0
FC.22	PLC 7th step running time	Setting range: 0.0-6500.0(s/m/h)	Factory default: 10.0

FC.23	PLC 8th step running time	Setting range: 0.0-6500.0(s/m/h)	Factory default: 10.0
FC.24	PLC 9th step running time	Setting range: 0.0-6500.0(s/m/h)	Factory default: 10.0
FC.25	PLC 10th step running time	Setting range: 0.0-6500.0(s/m/h)	Factory default: 10.0
FC.26	PLC 11th step running time	Setting range: 0.0-6500.0(s/m/h)	Factory default: 10.0
FC.27	PLC 12th step running time	Setting range: 0.0-6500.0(s/m/h)	Factory default: 10.0
FC.28	PLC 13th step running time	Setting range: 0.0-6500.0(s/m/h)	Factory default: 10.0
FC.29	PLC 14th step running time	Setting range: 0.0-6500.0(s/m/h)	Factory default: 10.0
FC.30	PLC 15th step running time	Setting range: 0.0-6500.0(s/m/h)	Factory default: 10.0

Set running time of every 15 step. Time unit is decided by [FC.15] LED "00" digit setting.

FC.31	PLC 1st step direction and ADD/DEC time	Setting range:0000-0031	Factory default: 0000
FC.32	PLC 2nd step direction and ADD/DEC time		Factory default: 0000
FC.33	PLC 3rd step direction and ADD/DEC time		Factory default: 0000
FC.34	PLC 4th step direction and ADD/DEC time		Factory default: 0000
FC.35	PLC 5th step direction and ADD/DEC time		Factory default: 0000
FC.36	PLC 6th step direction and ADD/DEC time		Factory default: 0000
FC.37	PLC 7th step direction and ADD/DEC time		Factory default: 0000
FC.38	PLC 8th step direction and ADD/DEC time		Factory default: 0000
FC.39	PLC 9th step direction and ADD/DEC time		Factory default: 0000
FC.40	PLC 10th step direction and ADD/DEC time		Factory default: 0000
FC.41	PLC 11th step direction and ADD/DEC time		Factory default: 0000
FC.42	PLC 12th step direction and ADD/DEC time		Factory default: 0000
FC.43	PLC 13th step direction and ADD/DEC time		Factory default: 0000
FC.44	PLC 14th step direction and ADD/DEC time		Factory default: 0000
FC.45	PLC 15th step direction and ADD/DEC time		Factory default: 0000

Set running direction and ACC/DEC time of every 15 step when running.

LED "0" digit: run direction of this step

0: FWD

1: REV

When [F0.07] LED "00" digit is 0 frequency control direction invalid or [F0.16] is 2 JOG forbidden and the speed is REV, inverter runs as 0.00Hz.

LED "00" digit: ACC/DEC time in this step

0: ACC/DEC time 1

1: ACC/DEC time 2

2: ACC/DEC time 3

4: ACC/DEC time 4

LED "000" digit: reserved

LED "0000" digit: reserved

FC.46-FC.48	Reserved
-------------	----------

FC.49	Swing frequency control	Setting range: 0000-0111	Factory default: 0000
FC.50	Preset swing frequency	Setting range: 0.00-Max frequency	Factory default: 0.00Hz

FC.51	Preset frequency lasting time	Setting range: 0.00-650.00s	Factory default: 0.00s
FC.52	Swing frequency range	Setting range: 0.0-100.0%	Factory default: 0.0%
FC.53	Startup frequency range	Setting range: 0.0-50.0%	Factory default: 0.0%
FC.54	Swing frequency rising time	Setting range: 0.00-650.00s	Factory default: 5.00s
FC.55	Swing frequency falling time	Setting range: 0.00-650.00s	Factory default: 5.00s

The inverter changes output frequency periodically with a predetermined ACC/DEC time when swing frequency runs. This feature is especially useful in the textile industry.

Swing center frequency comes from given frequency of main and auxiliary channel or the set frequency in multi-speed or PLC running; swing frequency would be automatically canceled in jog and closed-loop running. When PLC and swing frequency run simultaneously, switching between the PLC segment and swing frequency would fail; swing frequency begins after transiting from PLC deceleration phase to PLC set frequency; press PLC stage ACC/DEC time to decelerate when stop.

Swing frequency generally as follows: first accelerate to the preset frequency [FC.50] according to the acceleration time and wait for time [FC.51], then transit according to swing center frequency according to ACC/DEC time, and then cycle run according to the swing frequency amplitude [FC.52], startup frequency [FC.53], swing frequency rising time [FC.54] and swing frequency falling time [FC.55] until the stop command by deceleration time.

LED "0" digit: swing frequency control

0: invalid

1: valid

LED "00" digit: swing frequency input mode

When the parameter defines the swing frequency control, swing frequency input mode.

0: automatic input

Run according to swing frequency [FC.50] with time decided by preset frequency [FC.51], then automatically entering the state of swing frequency running.

1: Manual input

Run according to swing frequency [FC.50], when multifunction input terminal swing frequency input terminal is valid, enter into swing frequency state; exit when invalid, the operating frequency is maintained at the preset swing frequency [FC.50].

LED "000" digit: swing amplitude control

0: variable: swing amplitude AW changes with the center frequency, the rate of change, see [FC.52] definition.

1: fixed: Amplitude AW is determined by the maximum frequency and [FC.52]

LED "0000" digit: reserved

Startup frequency amplitude: used to set the startup frequency when in swing frequency running, defined as the [FC.52] percentage.

Startup frequency: $\text{Swing frequency amplitude AW} \times [\text{FC.52}]$

Swing frequency preset frequency: used to set the running frequency of inverter before entering swing frequency state.

Preset frequency Duration: when swing frequency control "00" digit of [FC.49] is set to "0" automatically input; this parameter is used to set the swing preset frequency running duration before entering into swing frequency state; invalid when choosing manual input.

Swing frequency amplitude: This parameter defines the frequency amplitude when in swing frequency control.

Variable Swing: $\text{AW} = \text{center frequency} \times [\text{FC.52}]$

Fixed Swing: $\text{AW} = \text{maximum operating frequency} [\text{F0.09}] \times [\text{FC.52}]$

Swing frequency rising time: used to set the ACC time of swing frequency.

Swing frequency falling time: used to set the DEC time of swing frequency.

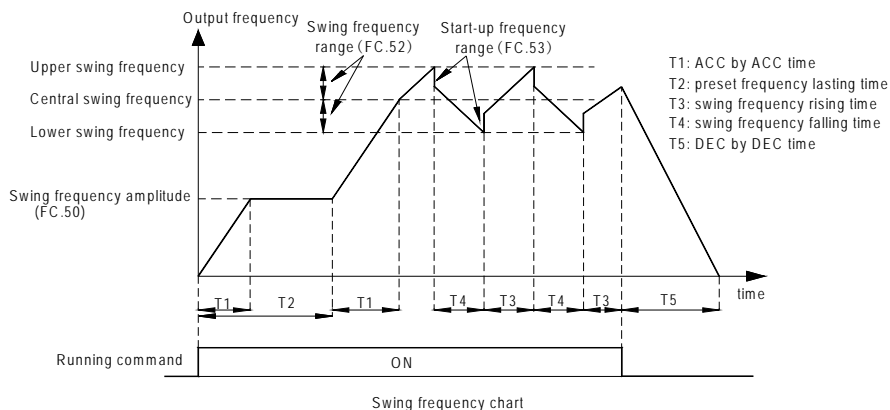

8.13 Communication Control Function Parameters

Fd.00	Main-slave machine Modbus and CAN	Setting range: 0000-0011	Factory default: 0000
-------	-----------------------------------	--------------------------	-----------------------

Choose inverter as main machine or slave machine when Modbus communication. Details for Modbus, refer to Appendix 2:RS485 communication protocol.

LED "0" digit: Modbus Communication Main and Slave Selection

0: Slave machine Inverter is slave machine. Communication address is decided by [Fd.01]. Inverter receives order from main machine and decides whether to reply or not when writing operation according to [Fd.08] setting. Reply delay time is set by [Fd.05].

1: Main machine Inverter, as main machine, sends data to communication network by broadcast orders. All slave machines accept orders from main machine. The data sending of main machine is set by [Fd.09].

LED "00" digit: CAN Communication Main and Slave Selection

0: Slave machine Inverter is CAN self-defined protocol slave machine or CANopen slave machine, receiving data from main machine on the network.

1: Main machine Inverter, as main machine, sends data to communication network by broadcast orders. All slave machines accept orders from main machine. The data sending of main machine is set by [Fd.09].

Note: when inverter is regarded as the main machine setting an network, all slave machines can only be connected to the network when using inverters of VEICHI; The main machine sends broadcast data by self-defined free protocol.

Fd.01	Modbus communication slave machine address	Setting range: 1-247	Factory default: 1
-------	--	----------------------	--------------------

It sets communication address when inverter is slave machine. If inverter is main machine, this parameter has no meaning. 0 is the broadcast address.

Fd.02	Communication baud rate selections	Setting range: 0000-0065	Factory default: 0043
-------	------------------------------------	--------------------------	-----------------------

LED "0" digit: Modbus communication baud rate: set the communication baud rate

- 0: 1200 bps
- 1: 2400 bps
- 2: 4800 bps
- 3: 9600 bps
- 4: 19200 bps
- 5: 38400 bps

LED "00" digit: CAN communication baud rate: set the communication baud rate

- 0: 20 kbps
- 1: 50 kbps
- 2: 100kbps
- 3: 125kbps
- 4: 250kbps
- 5: 500kbps
- 6: 1Mbps

Fd.03	Data format of Modbus	Setting range: 0-5	Factory default: 0
-------	-----------------------	--------------------	--------------------

Set the Data format of Modbus when communication; can't communicate when the data format is set differently.

- 0: (N, 8, 1) no checkout, Data digit: 8, Stop digit: 1
- 1: (E, 8, 1) even checkout, Data digit: 8, Stop digit: 1
- 2: (O, 8, 1) odd checkout, Data digit: 8, Stop digit: 1
- 3: (N, 8, 2) no checkout, Data digit: 8, Stop digit: 2
- 4: (E, 8, 2) even checkout, Data digit: 8, Stop digit: 2
- 5: (O, 8, 2) odd checkout, Data digit: 8, Stop digit: 2

Fd.04	Communication ratio setting	Setting range: 0.00-5.00	Factory default: 1.00
-------	-----------------------------	--------------------------	-----------------------

The result of upper machine multiplies this parameter is the communication given or feedback of this machine. Upper machine communication order can be modified in proportion.

Fd.05	Communication answer delay	Setting range: 0-500ms	Factory default: 0ms
-------	----------------------------	------------------------	----------------------

When delay time is shorter than system dealing time, real delay time is same as system dealing time. When delay time is longer than system dealing time, it has to delay when system dealing finished. It does not send data to upper machine until delay time arrive.

Fd.06	Communication overtime fault time	Setting range: 0.1-100.0s	Factory default: 1.0s
Fd.07	RS485 communication fault act mode selections	Setting range: 0-3	Factory default: 1

Modbus communication overtime fault time: If the interval between one communication and next communication is over communication overtime, it is considered as communication break fault. [Fd.07] decides the act mode.

Modbus communication fault action mode selections:

0: Alarm and stop freely: If it has not received next frame order or other communication order when the latest communication giving order is over [Fd.06] time setting, inverter alarms fault E.CE and stops.

1: Not alarm, go on running: Inverter does not inspect fault and always runs according to the latest order.

2: Stop without alarm (running order given by communication) If it has not received next frame order or other communication order when the latest

Communication giving order is over [Fd.06] time setting. Inverter will clear orders before and back to standby state.

3: Stop without alarm (running order given by all channels) Frequency inverter stop when communication giving order is more than [Fd.06] setting time and does not receive next frame order or other communication order.

Fd.08	Modbus transmission response	Setting range:0-1	Factory default: 0
-------	------------------------------	-------------------	--------------------

The parameter chooses whether to respond when the upper computer issues a write command to the drive. If the upper computer needs the reply from the drive, the drive will occupy sharing communication bus; when doing communications control, the upper computer need to retain enough time to reply. If the upper computer does not need a reply message but only send commands to the drive, you can choose no respond to write operation to improve the utilization efficiency of the communication bus. This parameter is valid only for write operation, invalid for read operation.

0: write operation with response

1: write operation without response

Fd.09	Main machine sending selections	Setting range: 0000-AAAA	Factory default: 0031
-------	---------------------------------	--------------------------	-----------------------

Set the data that inverter sent the slave machines when inverter is main machine.

When setting the inverter as the communication host sending data to the slave machine, all slaves will receive the command from the host when the host drive sends broadcast commands.

The host can send four polling data, corresponding to the settings of LED "0" digit, "00" digit, "000" digit and "0000" digit.

No data is transmitted when invalid.

LED "0" digit: 1st group of frame selection

0: invalid

1: run order given

2: main machine given frequency

3: main machine output frequency

4: main machine max frequency

5: main machine set torque

6: main machine output torque

7: torque mode FWD speed control

8: torque mode REV speed control

9: main machine given PID

A: main machine feedback PID

B: voltage frequency separate voltage order given

LED "00" digit: 2nd group of frame selection as above

LED "000" digit: 3rd group of frame selection as above

LED "0000" digit: 4th group of frame selection as above

Fd.10	RS485 communication port configuration	Setting range: 0-2	Factory default: 0
-------	--	--------------------	--------------------

RS485 communication port configuration

- 0: ModBus communication: general ModBus method
 1: Serial port monitoring: monitoring inverter running state by upper computer.
 2: Reserved

Fd.11	CAN communication protocol selection	Setting range: 0-2	Factory default: 0
-------	--------------------------------------	--------------------	--------------------

CAN communication protocol: select CAN communication protocol;

- 0: CANopen protocol: select CANopen protocol, see CANopen extended card.
 1: CAN self-defined protocol: select CAN self defined protocol for network of VEICHI inverters
 2: CAN Oscilloscope protocol: use this protocol when using CAN interface Oscilloscope

Tip: When [Fd.0A] = 1 or [Fd.11] = 2, normal operations can be achieved by corresponding PC software provided by required manufacturers.

Fd.12	CAN communication slave machine address	Setting range: 0-127	Factory default: 1
-------	---	----------------------	--------------------

Set CAN communication as the slave machine address

Fd.13	CAN main machine sending selection	Setting range: 0000-AAAA	Factory default: 0031
-------	------------------------------------	--------------------------	-----------------------

When setting the inverter as the CAN self defined communication host sending data to the slave machine, all slaves will receive the command from the host when the host drive sends broadcast commands.

The host can send four polling data, corresponding to the settings of LED "0" digit, "00" digit, "000" digit and "0000" digit. No data is transmitted when invalid.

LED "0" digit: 1st group of frame selection

- 0: invalid
 1: run order given
 2: main machine given frequency
 3: main machine output frequency
 4: main machine max frequency
 5: main machine set torque
 6: main machine output torque
 7: torque mode FWD speed control
 8: torque mode REV speed control
 9: main machine given PID
 A: main machine feedback PID
 B: voltage frequency separate voltage order given

LED "00" digit: 2nd group of frame selection as above

LED "000" digit: 3rd group of frame selection as above

LED "0000" digit: 4th group of frame selection as above

8.14 Inverter Fault Code List

Communication code	Fault display	Fault
0	--	No fault
1	E. SC	Module fault
2	E. SC	Module fault
3	E. SC	Module fault
4	E.oC1	Over-current when ACC
5	E.oC2	Over-current when DEC
6	E.oC3	Over-current in stable speed
7	E.oU1	Over-voltage when ACC
8	E.oU2	Over-voltage when DEC
9	E.oU3	Over-voltage in stable speed
10	E.LU2	Under voltage in bus
11	E.oL1	Motor Overload
12	E.oL2	Inverter Overload
13	E.ILF	Input phase loss
14	E.oLF	Output phase loss
15	E.oH2	Rectifier over-heat
16	E.oH1	Inverter over-heat
17	E. EF	External fault
18	E. CE	Communication fault
19	E.HAL	Current detecting fault
20	E.TE1	Motor static self study
21	E.EEP	EEPROM fault
22	Reserved	Reserved
23	E.BRU	Breaking unit fault
24	Reserved	Reserved
25	E.TE2	Motor dynamic self study
26	E.CPE	Parameter copy abnormal
27	E. PG	Extended card connecting abnormal
28	E.OU4	Over-voltage when stop
29	E.PID	PID break fault

Input Terminal on/off Diagram:

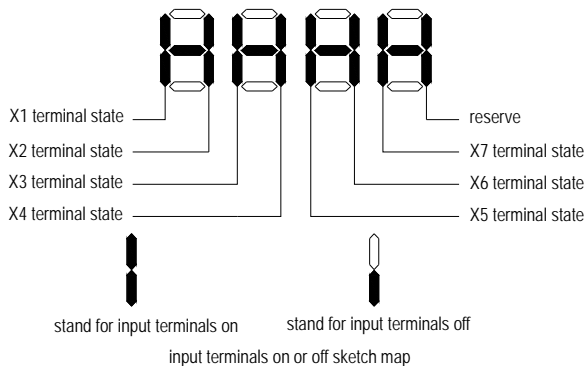

Output Terminal on/off Diagram:

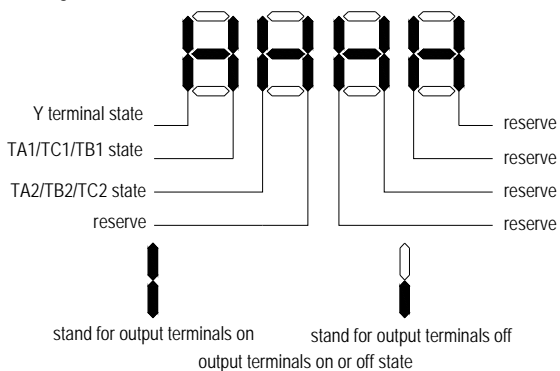

Tip: C-31 monitoring expansion output relay TA3-TC3, TA4-TC4 connection diagrams are the same as the diagram above, but only displaying the first two valid digits.

Chapter 9 Appendix

9.1 Appendix 1: Function Parameters Summary Table

- “●”: Parameter can be changed in running state.
- “○”: Parameter can't be changed in running state.
- “×”: Parameter can be read only.
- “_”: Factory setting parameter, only factory can set.
- “※”: Parameter is related to the model.

Basic Parameter Group

NO.	Function description	Range of settings and definition	Factory default	Feature	Address
F0.00	Control mode	Asynchronous motor control mode: 0: High-performance VC without PG 1: VC without PG 2: High-performance VC with PG 3: VC with PG 4: V/F control Synchronous motor control mode: 5: High-performance VC without PG 6: VC without PG 7: VC with PG Other control: 8: Voltage frequency differential output	1	○	0x000
F0.01	Speed/torque control mode	0: speed control 1: torque control	0		0x001
F0.02	Run command channel	0: Keyboard control 1: Terminal control 2: RS485 communication control 3: Optional card (communication)	0	○	0x002
F0.03	Frequency given main channel selection	0: Keyboard number given frequency 1: Keyboard potentiometer given 2: Terminal VS analog given 3: Terminal AI analog given 4: Terminal AS analog given 5: Terminal pulse signal given 6: RS485 communication port given 7: UP/DW control given 8: PID control given 9: Program control (PLC) given 10: Optional card (communication) 11: VS3 (Extended) 12: Terminal switching	0	○	0x003
F0.04	Main channel gain	0.000~5.000	1.000	○	0x004

F0.05	Frequency given auxiliary channel selection	0: Keyboard digital given frequency 1: Keyboard potentiometer given 2: Terminal VS analog given 3: Terminal AI analog given 4: Terminal AS analog given 5: Terminal pulse signal given 6: RS485 communication port given	1	○	0x005
F0.06	Auxiliary channel gain	0.000~5.000	1.000	○	0x006
F0.07	Frequency given channels combination mode	LED*0*digit: 0: Main channel valid 1: Auxiliary channel valid 2: Main + auxiliary 3: Main-auxiliary 4: MAX{ main, auxiliary } 5: MIN{ main, auxiliary } 6: Main*auxiliary LED*10*digit: 0: Direction of frequency control invalid 1: Direction of frequency control invalid LED*100*digit: Reserved LED*1000*digit: Reserved	0000	○	0x007
F0.08	Keyboard number setting frequency	0~upper limit	50.00Hz	●	0x008
F0.09	Max frequency output	0~320.00Hz	50.00Hz	○	0x009
F0.10	Upper limitation source selection	0: Upper limit frequency digital given 1: Keyboard potentiometer given 2: Terminal VS analog given 3: Terminal AI analog given 4: Terminal AS analog given 5: Terminal pulse signal given 6: RS485 communication port given 7: Optional card (communication) 8: VS3 (Extended)	0	○	0x00A
F0.11	Upper frequency limit digital setting	Lower frequency limit~max output frequency	50.00Hz	●	0x00B
F0.12	lower frequency limit	0~upper limit	0.00Hz	●	0x00C
F0.13	Lower frequency limit running mode	0: Stop 1: Run as lower frequency limit	1	○	0x00D
F0.14	ACC time 1	0.01~650.00s	Model set	●	0x00E
F0.15	DEC time 1	0.01~650.00s	Model set	●	0x00F

F0.16	Rotary direction selection	0: Consistent 1: Reverse 2: Reverse banned	0	●	0x010
F0.17	Carrier frequency	0.6~15.0kHz	Model set	●	0x011
F0.18	Carrier frequency PWM characteristic selection	LED*0*digit: carrier frequency relates with temperature 0: Unrelated to temperature 1: Related to temperature LED*10*digit: carrier frequency relates with output frequency 0: Unrelated to frequency output 1: Related to frequency output LED*100*digit: carrier frequency mode 0: Fixed carrier 1: Random carrier LED*1000*digit: Over modulation options 0: close 1: open	0010	●	0x012
F0.19	Parameter initialization	0: No action 1: Restore factory default (not restoring motor parameters) 2: Clear malfunction records 3: Restore factory default (restoring motor parameters)	0	○	0x013
F0.20	Over modulation function selection	0: close 1: open	1	●	0x014
F0.21	Reserved				0x015
F0.22	Reserved				0x016
F0.23	Reserved				0x017
F0.24	Running command bonding	LED*0*digit: keyboard command instruction bonding LED*00*digit: terminal command instruction bonding LED*000*digit: communication command instruction bonding LED*0000*digit: optional card command instruction bonding 0: no bonding 1: keyboard number given frequency 2: Keyboard potentiometer given 3: Terminal VS voltage analog given 4: Terminal AI voltage/current analog given 5: Terminal AS current analog given 6: Terminal pulse signal given	0000	○	0x018

F0.24	Running command bonding	7: RS485 communication port given 8: Terminal UP/DW control given 9: PID control given 10: Program control (PLC) given 11: Optional card 12: VS3 (Extended)	0000	○	0x018
F0.25	Reserved				0x019
F0.26	Voltage frequency differential output voltage source	0: function code F0.27 setting 1: Terminal VS voltage analog given 2: Terminal AI voltage/current analog given 3: Terminal AS current analog given 4: Terminal pulse signal given 5: PID control given 6: RS485 communication port given 7: Optional card 8: VS3 (Extended)	0	○	0x01A
F0.27	Voltage frequency differential output voltage digit setting	0.0% ~100.0%	0	●	0x01B
F0.28	Voltage frequency differential voltage rising slope	0.0 ~1000.0s	1.0s	●	0x01C
F0.29	Voltage frequency differential voltage falling slope	0.0 ~1000.0s	1.0s	●	0x01D
F0.30	Voltage frequency differential stop mode	0: voltage/frequency decreasing to 0 at the same time 1: frequency start to fall after voltage reaches 0	0	●	0x01E

Running Control Parameter Group

NO.	Function description	Range of settings and definition	Factory default	Feature	Address
F1.00	Start-up mode running	0: Start directly 1: Braking first then start by start frequency 2: Speed tracking, judge direction then start	0	○	0x100
F1.01	Start pre-excitation time	0.00-60.00s	Model set	●	0x101
F1.02	Start frequency	0.00~60.00Hz	0.50Hz	●	0x102
F1.03	Start frequency hold time	0.0~50.0s	0.0s	●	0x103

F1.04	Braking current before start	0~150.0%	0.0%	●	0x104
F1.05	Braking time before start	0.0~60.0s	0.0s	●	0x105
F1.06	Speed tracking stability waiting time	0.00~60.00s	0.5s	●	0x106
F1.07	Stop mode	0: DEC to stop 1: Free stop	0	●	0x107
F1.08	DC braking initial frequency	0.00~50.00Hz	0.00Hz	●	0x108
F1.09	DC braking current	0.0~150.0%	0.0%	●	0x109
F1.10	DC braking waiting time	0.0~60.0s	0.0s	●	0x10A
F1.11	DC braking duration	0.0~60.0s	0.0s	●	0x10B
F1.12	Reserved				0x10C
F1.13	ACC/DEC mode selection	LED "0" digit: ACC/DEC time base 0: max frequency 1: fixed frequency LED "00" digit: ACC/DEC mode 0: Beeline 1: S Curve LED "000" digit: reserved LED "0000" digit: reserved	0000	○	0x10D
F1.14	Start ACC rate of S curve	20.0%-100.0%	50.0%	●	0x10E
F1.15	ACC slope increment of S curve	20.0%-100.0%	50.0%	●	0x10F
F1.16	Reserved				0x110
F1.17	Reserved				0x111
F1.18	ACC time 2	0.01-650.00s	10.00s	●	0x112
F1.19	DEC time 2	0.01-650.00s	10.00s	●	0x113
F1.20	ACC time 3	0.01-650.00s	10.00s	●	0x114
F1.21	DEC time 3	0.01-650.00s	10.00s	●	0x115
F1.22	ACC time 4	0.01-650.00s	10.00s	●	0x116
F1.23	DEC time 4	0.01-650.00s	10.00s	●	0x117
F1.24	Emergency stop DEC time	0.01-650.00s	10.00s	●	0x118
F1.25	FWD&REV dead time	0.0~120.0s	0.0s	●	0x119
F1.26	Min output frequency	0.00-60.00Hz	0.50Hz	●	0x11A
F1.27	0 speed hold torque	0.0-150.0%	Model set	●	0x11B

F1.28	0 speed hold torque time	If set between 0.0-5999.9s, 0 speed hold torque keep setting time. If set 6000.0s, 0 speed hold torque no time limit	0.0s	●	0x11C
F1.29	Power off restart action selection	0: Invalid 1: Valid	0	●	0x11D
F1.30	Power off restart waiting time	0.00-120.00s	0.50s	●	0x11E
F1.31	Terminal running protection selection	LED "0" digit: run command selection when electrifying 0: Terminal running order invalid when electrifying 1: Terminal running order valid when electrifying LED "10" digit: when switching the run command given channel 0: invalid 1: valid	11	●	0x11F
F1.32	JOG running frequency setting	0.00-Max frequency	5.00Hz	●	0x120
F1.33	JOG ACC time	0.01-650.00s	10.00s	●	0x121
F1.34	JOG DEC time	0.01-650.00s	10.00s	●	0x122
F1.35	Jump frequency	0.00-Max frequency	0.00Hz	●	0x123
F1.36	Jump frequency range	0.00-Max frequency	0.00Hz	●	0x124

Quantum Digital Terminal Parameter Group

NO.	Function description	Range of settings and definition	Factory default	Feature	Address
F2.00	Multifunction input terminal 1(X1)	0: No function 1: FWD 2: REV 3: 3-line running control 4: FWD JOG 5: REV JOG 6: Free stop 7: Emergency stop 8: Malfunction reset 9: External fault input 10: Frequency UP 11: Frequency DW 12: UP/DW clear 13: Speed torque control clear (UP/DOWN clear o) 14: Torque control banned	1	●	0x200

F2.01	Multifunction input terminal 2(X2)	15: Multispeed terminal1 16: Multispeed terminal 2 17: Multispeed terminal 3 18: Multispeed terminal 4 19: ACC/DEC time choose terminal 1 20: ACC/DEC time choose terminal 2 21: ACC/DEC pause 22: PID control cancel 23: PID control pause 24: PID characteristic switch	2	●	0x201
F2.02	Multifunction input terminal 3(X3)	25: PID given switch 1 26: PID given switch 2 27: PID given switch 3 28: PID feedback switch 1 29: PID feedback switch 2	4	●	0x202
F2.03	Multifunction input terminal 4(X4)	30: PID feedback switch 3 31:PLC pause 32: PLC restart 33: Swing frequency input 34: Swing frequency pause 35: Swing frequency reset	5	●	0x203
F2.04	Multifunction input terminal 5(X5)	36: Frequency channel switching terminal 1 37: Frequency channel switching terminal 2	6	●	0x204
F2.05	Multifunction input terminal 6(X6)	38: Frequency channel switching terminal 3 39: Frequency channel switching terminal 4 40: Timer trigger terminal 41: Timer clear zero terminal	8	●	0x205
F2.06	Multifunction input terminal 7(X7/PUL)	42: Timer clock input terminal 43: Counter clear terminal 44: DC braking order 45: Pre excitation order terminals 46: Motor selection terminal 47: Reserved	10	●	0x206
F2.07	Reserved				0x207

F2.08	X1-X4 terminal feature selection	LED "0" digit: X1 terminal 0: On valid 1: Off valid LED "00" digit: X2 terminal 0: On valid 1: Off valid LED "000" digit: X3 terminal 0: On valid 1: Off valid LED "0000" digit: X4terminal 0: On valid 1: Off valid	0000	○	0x208
F2.09	X1-X4 input terminal filer time	0.000-60.000s	0.010s	●	0x209
F2.10	X5-X7 terminal feature selection	LED "0" digit: X5 terminal 0: On valid 1: Off valid LED "00" digit: X6 terminal 0: On valid 1: Off valid LED "000" digit: X7 terminal 0: On valid 1: Off valid LED "0000" digit::reserved	0000	○	0x20A
F2.11	X5-X7 input terminal filer time	0.000-60.000s	0.010s	●	0x20B
F2.12	Terminal control mode	0: 2-line 1 1: 2-line 2 2: 3-line 1 3: 3-line 2	0	○	0x20C
F2.13	Terminal action mode	LED "0" digit: free stop terminal reset mode 0: Reset to original order when invalid 1: Not reset to original order when invalid LED "00" digit: emergency stop terminal reset mode 0: Reset to original order when disconnected 1: Not reset to original order when disconnected LED "000" digit: terminal run mode after fault reset 0: Terminal control to power on directly 1: Terminal control to power on after stop LED "0000" digit: reserved	0111	○	0x20D

F2.14	Reserved				0x20E
F2.15	Reserved				0x20F
F2.16	PUL input min frequency	0.0-50.00kHz	0.00kHz	●	0x210
F2.17	PUL min frequency corresponding setting	0.00-100.00%	0.00%	●	0x211
F2.18	PUL input max frequency	0.0-50.00kHz	50.00kHz	●	0x212
F2.19	PUL max frequency corresponding setting	0-100.00%	100.00%	●	0x213
F2.20	PUL filter time	0.00s-10.00s	0.10s	●	0x214
F2.21	PUL cut-off frequency	0.000-1.000kHz	0.010kHz	●	0x215
F2.22	UP/DW terminal frequency control mode	0: Off electricity storage 1: Off electricity does not storage 2: Valid in running, clear zero at stop	0	●	0x216
F2.23	ACC/DEC speed of UP/DW terminal frequency	0.01~50.00Hz/s	0.50Hz/s	●	0x217
F2.24	Reserved				0x218
F2.25	Timer time of unit	0: Second 1: Minute 2: Hour	0	●	0x219
F2.26	Timer setting	0~65000	0	●	0x21A
F2.27	Counter max value	0~65000	1000	●	0x21B
F2.28	Counter setting value	0~65000	500	●	0x21C
F2.29	Output terminal (Y)	0: No output 1: FWD Running 2: REV Running 3: Fault trip alarm 1(alarm when fault self-recover) 4: Fault trip alarm 2(no alarm when fault self-recover) 5: Fault retrying 6: External fault stop 7: Under voltage 8: Finish ready for running 9: Output frequency level test 1(FDT1)	0	●	0x21D

F2.30	Output relay 1 (TA1-TB1-TC1)	10: Output frequency level test 2(FDT2) 11: Reaching given frequency 12: running at 0 speed 13: Reaching upper frequency limit 14: Reaching lower frequency limit 15: Program running circle period completed 16: Program running Speed completed 17: PID feedback exceeds upper limit 18: PID feedback under lower limit 19: PID feedback sensor wire break 20: Motor overload pre alarm 21: Timer time arrived 22: Counter reaching biggest value 23: Counter reaching setting value 24: Energy braking 25: PG feedback break 26: Emergency stop 27: Pre alarm output for over load 28: Pre alarm output for under load	1	●	0x21E
F2.31	Relay output terminal (TA-TB-TC)	21: Timer time arrived 22: Counter reaching biggest value 23: Counter reaching setting value 24: Energy braking 25: PG feedback break 26: Emergency stop 27: Pre alarm output for over load 28: Pre alarm output for under load	3	●	0x21F
F2.32	Output frequency level 1 (FDT1)	0.00~Max frequency	30.00Hz	●	0x220
F2.33	FDT1 lag	0.00~Max frequency	0.00Hz	●	0x221
F2.34	Output frequency level 2 (FDT2)	0.00~Max frequency	50.00Hz	●	0x222
F2.35	FDT2 lag	0.00~Max frequency	0.00Hz	●	0x223
F2.36	Speed arriving checkout range	0.00-50.00Hz	0.50Hz	●	0x224
F2.37	Over load pre alarm level	0.0-200.0%	180.0%	●	0x225
F2.38	Over load pre alarm delay	0.0-100.0s	0.5s	●	0x226
F2.39	Under load pre alarm level	0.0-200.0%	30.0%	●	0x227
F2.40	Under load pre alarm delay	0.0-100.0s	0.5s	●	0x228
F2.41	X1 rising delay time	0.0~360.0s	0	●	0x229
F2.42	X1 falling delay time selection	0.0~360.0s	0	●	0x22A
F2.43	X2 rising delay time selection	0.0~360.0s	0	●	0x22B
F2.44	X2 falling delay time	0.0~360.0s	0	●	0x22C
F2.45	X3 rising delay time	0.0~360.0s	0	●	0x22D

F2.46	X3 falling delay time	0.0~360.0s	0	●	0x22E
F2.47	Y output delay time	0.0~360.0s	0	●	0x22F
F2.48	Relay 1 output delay time	0.0~360.0s	0	●	0x230
F2.49	Relay 2 output delay time	0.0~360.0s	0	●	0x231
F2.50	Reserved				0x232
F2.51	Virtual vX1 terminal function selection	See X terminal function input	0	●	
F2.52	Virtual vX2 terminal function selection		0	●	0x234
F2.53	Virtual vX3 terminal function selection		0	●	0x235
F2.54	Virtual vX4 terminal function selection		0	●	0x236
F2.55	vX terminal valid state source	0: internal connection with virtual vYn 1: function code setting valid or not LED "0" digit: virtual vX1 LED "00" digit: virtual vX2 LED "000" digit: virtual vX3 LED "0000" digit: virtual vX4	0000	●	0x237
F2.56	Virtual vX terminal function code setting valid state	0: invalid 1: valid LED "0" digit: virtual vX1 LED "00" digit: virtual vX2 LED "000" digit: virtual vX3 LED "0000" digit: virtual vX4	0000	○	0x238
F2.57	VS terminal function selection (X)	See X terminal function input	0	●	0x239
F2.58	AI terminal function selection (X)		0	●	0x23A
F2.59	AS terminal function selection (X)		0	●	0x23B
F2.60	Analog terminal valid state setting	0: low level 1: high level LED "0" digit: VS LED "00" digit: AI LED "000" digit: AS	000	○	0x23C
F2.61	Virtual vY1 output selection	See Y terminal and relay function output	0	●	0x23D
F2.62	Virtual vY2 output selection		0	●	0x23E
F2.63	Virtual vY3 output selection		0	●	0x23F

F2.64	Virtual vY4 output selection		0	●	0x240
F2.65	vY1 output delay time	0.0s~999.9s	0	●	0x241
F2.66	vY2 output delay time	0.0s~999.9s	0	●	0x242
F2.67	vY3 output delay time	0.0s~999.9s	0	●	0x243
F2.68	vY4 output delay time	0.0s~999.9s	0	●	0x244
F2.69	Terminal input extend(X8)	See X terminal function	0	●	0x245
F2.70	Terminal input extend (X9)		0	●	0x246
F2.71	Terminal input extend (X10)		0	●	0x247
F2.72	X8~X10 input terminal filter time	0.000~60.000s	0.010s	●	0x248
F2.73	X8~X10 terminal feature selection	LED "0" digit: X8 terminal 0: on valid 1: off valid LED "00" digit: X9 terminal 0: on valid 1: off valid	0x000	●	0x249
F2.74	Output extended relay 3 (TA3-TC3)	See Y terminal function	0	●	0x24A
F2.75	Output extended relay 4 (TA4-TC4)		0	●	0x24B

Analog Terminal Parameter Group

NO.	Function description	Range of settings and definition	Factory default	Feature	Address
F3.00	VS Lower limit	0.00V-10.00V	0.00V	●	0x300
F3.01	VS Lower limit corresponding setting	0.00-100.00%	0.00%	●	0x301
F3.02	VS upper limit	0.00V-10.00V	10.00V	●	0x302
F3.03	VS upper limit corresponding setting	0.00-100.00%	100.00%	●	0x303
F3.04	VS filter time	0.00s-10.00s	0.10s	●	0x304
F3.05	AI lower limit when used as VS	0.00V-10.00V	0.00V	●	0x305
F3.06	AI lower limit corresponding setting	0.00-100.00%	0.00%	●	0x306

F3.07	AI upper limit when used as VS	0.00V-10.00V	10.00V	●	0x307
F3.08	AI upper limit corresponding setting	0.00-100.00%	100.00%	●	0x308
F3.09	AI filter time	0.00s-10.00s	0.10s	●	0x309
F3.10	AS lower limit	0.00-20.00mA	4.00mA	●	0x30A
F3.11	AS lower limit corresponding setting	0.00-100.00%	0.00%	●	0x30B
F3.12	AS upper limit	0.00-20.00mA	20.00mA	●	0x30C
F3.13	AS upper limit corresponding setting	0-100.00%	100.00%	●	0x30D
F3.14	AS filter time	0.00s-10.00s	0.10s	●	0x30E
F3.15	Analog input curve selection	LED "0" digit: VS LED "00" digit: AI (Select voltage or current input by switch) LED "000" digit: AS 0: Beeline 1: curve 1 2: curve 2	000	○	0x30F
F3.16	AI(AS) lower limit	0.00~20.00mA	20.00mA	●	0x310
F3.17	AI(AS) lower limit corresponding setting	0.00~100.00%		○	0x311
F3.18	AI(AS) upper limit	0.00~20.00mA		○	0x312
F3.19	AI(AS) upper limit corresponding setting	0.00~100.00%		○	0x313
F3.20	Reserved			○	0x314
F3.21	A0 output signal selection	LED "0" digit: A01 output selection 0: 0~10V 1: 4.00~20.00mA 2: 0.00~20.00mA LED "00" digit: A02 output selection 0: 0~10V 1: 4.00~20.00mA 2: 0.00~20.00mA 3: FM frequency pulse output		○	0x315
F3.22	A01 output selection	0: Given frequency 1: Output frequency 2: Output current 3: Input voltage 4: Output voltage 5: Machine speed 6: Reserved 7: Output torque 8: PID given value 9: PID feedback value	0	●	0x316

F3.23	A02 output selection	10: Output power 11: Bus voltage 12: VS input value 13: AI input value 14: AS input value 15: PUL input value 16: Module temperature 1 17: Module temperature 2	1	●	0x317
F3.24	A01 output gain	25.0~200.0%	100.0%	●	0x318
F3.25	A01 output signal bias	-10.0~10.0%	0.0%	●	0x319
F3.26	Reserved				0x31A
F3.27	A02 output gain	25.0~200.0%	100.0%	●	0x31B
F3.28	A02 output signal bias	-10.0%~10.0%	0.0%	●	0x31C
F3.29	A02FM frequency output lower limit	0.00~50.00kHz	0.20kHz	●	0x31D
F3.30	A02FM frequency output upper limit	0.00~50.00kHz	50.00 kHz	●	0x31E
F3.31	Reserved				0x31F
F3.32	Curve 1 start point input	0.00~10.00V	0.00V	●	0x320
F3.33	Curve 1 start point input corresponding	0.00~100.00%	0.0%	●	0x321
F3.34	Curve 1 inflection point 1 input	0.00~10.00V	3.00V	●	0x322
F3.35	Curve 1 inflection point 1 input corresponding setting	0.00~100.00%	30.0%	●	0x323
F3.36	Curve 1 inflection point 2 input	0.00~10.00V	6.00V	●	0x324
F3.37	Curve 1 inflection point 2 input corresponding setting	0.00~100.00%	60.0%	●	0x325
F3.38	Curve 1 end point input	0.00~10.00V	10.0V	●	0x326
F3.39	Curve 1 end point input corresponding setting	0.00~100.00%	100.0%	●	0x327
F3.40	Curve 2 start point input	0.00~10.00V	0.00V	●	0x328
F3.41	Curve 2 start point input corresponding setting	0.00~100.00%	0.0%	●	0x329

F3.42	Curve 2 inflection point 1 input	0.00~10.00V	3.00V	●	0x32A
F3.43	Curve 2 inflection point 1 input corresponding setting	0.00~100.00%	30.0%	●	0x32B
F3.44	Curve 2 inflection point 2 input	0.00~10.00V	6.00V	●	0x32C
F3.45	Curve 2 inflection point 2 input corresponding setting	0.00~100.00%	60.0%	●	0x32D
F3.46	Curve 2 end point input	0.00~10.00V	10.00V	●	0x32E
F3.47	Curve 2 end point input corresponding setting	0.00~100.00%	100.0%	●	0x32F
F3.48	VS3(extended) lower limit	-10.00V~10.00V	-10.00V	●	0x330
F3.49	VS3(extended) lower limit corresponding setting	-100.00%~100.00%	-100.00%	●	0x331
F3.50	VS3(extended) upper limit	-10.00V~10.00V	10.00V	●	0x332
F3.51	VS3(extended) upper limit corresponding setting	-100.00%~100.00%	100.00%	●	0x333
F3.52	VS3(extended) filter time	0.00~10.00s	0.10s	●	0x334

Keyboard and Display Parameter Group

NO.	Function description	Range of settings and definition	Factory default	Feature	Address
F4.00	Parameter and key lock selections	0: Not locked 1: Function parameter locked 2: Function parameter and key locked (except for RUN/STOP/JOG) 3: All function parameter and key locked	0	●	0x400
F4.01	User password	0-9999	0	●	0x401
F4.02	REV/JOG selections	0: REV 1: JOG	0	●	0x402

F4.03	STOP key function range	LED "0" digit: terminal control 0: invalid to terminal order 1: valid to terminal order LED "00" digit: communication control 0: invalid to communication order 1: valid to communication order LED "000" digit: reserved LED "0000" digit: reserved	0000	●	0x403
F4.04	UP/DOWN key modification selections	LED "0" digit: keyboard UN/DOWN key modify selection 0: Invalid 1: Modify frequency setting by keyboard numbers (F0.08) 2: Reserved 3: Modify PID give setting by keyboard numbers (Fb.01) 4: Reserved LED "00" digit: keyboard UN/DOWN key store selection 0: No save after power down 1: Save after power down LED "000" digit: reserved LED "0000" digit: reserved	0011	●	0x404
F4.05	Function parameter copy	0: No operation 1: Send inverter parameters to keyboard and save 2: Send parameters to keyboard and save	0	○	0x405
F4.06	Reserved				0x406
F4.07	Keyboard potentiometer lower limit	0.00V-5.00V	0.50V	●	0x407
F4.08	Keyboard potentiometer lower limit corresponding setting	0-100.00%	0.00%	●	0x408
F4.09	Keyboard potentiometer upper limit	0.00V-5.00V	4.50V	●	0x409
F4.10	Keyboard potentiometer upper limit corresponding setting	0-100.00%	100.00%	●	0x40A

F4.11	The display content of the first line in running state	<p>LED*0"digit: display the first group</p> <p>0: Given frequency</p> <p>1: Output frequency</p> <p>2: Output current</p> <p>3: Input voltage</p> <p>4: Output voltage</p> <p>5: Machine speed</p> <p>6: Reserved</p> <p>7: Output torque</p> <p>8: PID given value</p> <p>9: PID feedback value</p> <p>A: Output power</p> <p>B: Bus voltage</p> <p>C: Module temperature 1</p> <p>D: Module temperature 2</p> <p>E: ON/OFF state of input terminal X</p> <p>F: ON/OFF state of input terminal Y</p> <p>LED*10"digit: display the second group</p> <p>LED*100"digit: display the third group</p> <p>LED*1000" digit: display the fourth group</p>	42B1	●	0x40B
F4.12	The display content of the first line in stop state	<p>LED *0" digit: display the first group</p> <p>LED*00"digit:display the second group</p> <p>LED*000" digit: display the third group</p> <p>LED*0000"digit:display the fourth group</p>	42B0	●	0x40C
F4.13	The display content of the second line in running state	<p>LED *0" digit: display the first group</p> <p>LED*00"digit:display the second group</p> <p>LED*000" digit: display the third group</p> <p>LED*0000"digit:display the fourth group</p>	CA42	●	0x40D
F4.14	The display content of the second line in stop state	<p>LED *0" digit: display the first group</p> <p>LED*00"digit:display the second group</p> <p>LED*000" digit: display the third group</p> <p>LED*0000"digit:display the fourth group</p>	CA42	●	0x40E
F4.15	Rotate speed display coefficient	0.0-5000.0%	100.0%	●	0x40F

F4.16	Keyboard display item selection	LED "0" digit: LED display language 0: Chinese 1: English LED"00" digit: output frequency selection 0: Aim frequency 1: Synchronous frequency LED"000"digit: machine speed display selection 0: Aim speed 1: Actual speed LED"0000" digit: reserved	0000	●	0x410
-------	---------------------------------	--	------	---	-------

Motor Parameter Group

NO.	Function description	Range of settings and definition	Factory default	Feature	Address
F5.00	Motor mode	0: asynchronous motors (AM) 1: PMSM (PM)	0	×	0x500
F5.01	Number of motor poles	2-48	4	○	0x501
F5.02	Motor rated power	0.4-1000.0KW	Model set	○	0x502
F5.03	Motor rated	0.01Hz-max frequency	Model set	○	0x503
F5.04	Motor rated speed	0-65000rpm	Model set	○	0x504
F5.05	Motor rated voltage	0-1500V	Model set	○	0x505
F5.06	Motor rated current	0.1-2000.0A	Model set	○	0x506
F5.07	Motor no-load current	0.01-650.00A	Model set	○	0x507
F5.08	Motor stator resistance	0.001-65.000	Model set	○	0x508
F5.09	Motor rotor	0.001-65.000	Model set	○	0x509
F5.10	Motor stator & rotor inductance	0.1-6500.0mH	Model set	○	0x50A
F5.11	Motor stator & rotor mutual inductance	0.1-6500.0mH	Model set	○	0x50B
F5.12	Motor parameters self-adjustment selections	0: No operation 1: Rotary type self-study 2: Static type self-study	0	○	0x50C
F5.13	Reserved				0x50D
F5.14	Reserved				0x50E

F5.15	Speed feedback or encoder mode	LED "0" digit: encoder mode 0: 1-phase input 1: 2-phase input LED "00" digit: encoder direction 0: same direction 1: reverse direction LED "000" digit: wire break inspection 0: OFF 1: ON LED"0000"digit:reserved	0000	○	0x50F
F5.16	Photoelectric encoder lines	0-60000	1024	○	0x510
F5.17	PG wire break inspection time	0.100-60.000s	0.000s	●	0x511
F5.18	Resolver poles	2~128	2	○	0x512
F5.19	Encoder installation DEC speed ratio	0.100~50.000	1.000	○	0x513
F5.20	Encoder filter time	1 - 1000ms	8	●	0x514
F5.21	Synchronous machine stator resistance	0.001~65.000	Model set	○	0x515
F5.22	Synchronous machine d axis inductance	0.01mH~655.35mH	Model set	○	0x516
F5.23	Synchronous machine q axis inductance	0.01mH~655.35mH	Model set	○	0x517
F5.24	Synchronous machine back EMF	0.1V~1000.0V	Model set	○	0x518
F5.25	Synchronous machine encoder installation angle	0.0° ~360.0°	Model set	○	0x519
F5.26	High frequency injection frequency	50.0Hz~1000.0Hz	300.0Hz	○	0x51A
F5.27	High frequency injection voltage	0.1%~100.0%	20.0%	○	0x51B
F5.28	Back EMF current identification	0.1%~100.0%	80.0%	○	0x51C

VC Parameter Group

NO.	Function description	Range of settings and definition	Factory default	Feature	Address
F6.00	ASR proportional gain 1	0.00~1.00	0.20	●	0x600
F6.01	ASR integral time 1	0.01~10.00s	0.50s	●	0x601
F6.02	ASR differential time 1	0.0~100.0	0.0	●	0x602
F6.03	ASR filter time1	0.000~0.100s	0.005s	●	0x603
F6.04	ASR switch frequency 1	0.00~50.00Hz	5.00Hz	●	0x604
F6.05	ASR (speed loop)proportional gain	0.00~1.00	0.20	●	0x605
F6.06	ASR (speed loop) integral time 2	0.01~10.00s	0.50s	●	0x606
F6.07	ASR (speed loop) differential time 2	0.0~100.0s	0.0s	●	0x607
F6.08	ASR filter time 2	0.000~0.100s	0.005	●	0x608
F6.09	ASR switch frequency 2	0.00~50.00Hz	10.00Hz	●	0x609
F6.10	VC slip coefficient	0~250%	100%	●	0x60A
F6.11	Speed control Max output torque	0.0~200.0%	150.0%	●	0x60B
F6.12	Constant power area torque compensation start frequency	100.0%~500.0%	120.0%	●	0x60C
F6.13	Constant power area torque compensation coefficient	0~100%	30%	●	0x60D
F6.14	Constant power area limit start frequency	100.0%~500.0%	200.0%	●	0x60E
F6.15	Constant power area limit value	50~200%	120%	●	0x60F
F6.16	Current loop D-axis proportional gain	0.1~10.0	1.0	●	0x610
F6.17	Current loop D-axis integral gain	0.1~10.0	1.0	●	0x611
F6.18	Current loop Q-axis proportional gain	0.1~10.0	1.0	●	0x612
F6.19	Current loop Q-axis integral gain	0.1~10.0	1.0	●	0x613
F6.20	Reserved			●	0x614
F6.21	Reserved			●	0x615
F6.22	Reserved			●	0x616

F6.23	Reserved			●	0x617
F6.24	Reserved			●	0x618
F6.25	Vector torque boost gain	0~500%	100%	●	0x619
F6.26	Vector torque boost filter time	1~1000ms	20ms	●	0x61A
F6.27	Vector slip compensation gain	0~500%	30%	○	0x61B
F6.28	Vector slip compensation filter time	1~1000ms	100ms	●	0x61C
F6.29	Reserved			●	0x61D
F6.30	Reserved			●	0x61E
F6.31	MTPA gain	0.0~500.0%	0.0%	●	0x61F
F6.32	MTPAI filter time	0.0~999.9ms	100.0ms	●	0x620
F6.33	Reserved			●	0x621
F6.34	Reserved			●	0x622
F6.35	Reserved			●	0x623
F6.36	Synchronous machine weak magnetic current upper limit	0~200%	0%	●	0x624
F6.37	Synchronous machine weak magnetic feed forward gain	0~500%	100%	●	0x625
F6.38	Synchronous machine weak magnetic proportional gain	0~9999	2000	●	0x626
F6.39	Synchronous machine weak magnetic integral gain	0~9999	2000	●	0x627
F6.40	Reserved			●	0x628
F6.41	Reserved			●	0x629
F6.42	Open loop start mode	0: start directly 1: start with an angle	0	○	0x62A
F6.43	Reserved			●	0x62B
F6.44	Reserved			●	0x62C
F6.45	Stabilizer proportional gain	0.1%~100.0%	20.0%	●	0x62D
F6.46	Stabilizer filter time	1ms~1000ms	30ms	●	0x62E

F6.47	Low frequency rising amplitude	0.0%~200.0%	80.0%	●	0x62F
F6.48	Low frequency current rising cut-off frequency	0.00Hz~99.00Hz	50.00Hz	●	0x630
F6.49	Low frequency current D-axis gain	0.0~100.0	5.0	●	0x631
F6.50	Low frequency current Q-axis gain	0.0~100.0	5.0	●	0x632
F6.51	Magnetic flow setting intensity	0~500%	100%	●	0x633
F6.52	Magnetic flow control proportional gain	0~9999	2000	●	0x634
F6.53	Magnetic flow control integral gain	0~9999	2000	●	0x635
F6.54	Over current suppression point	0.0~250.0%	150.0%	●	0x636
F6.55	Over current suppression gain	0~500%	100%	●	0x637
F6.56	Over current suppression integral	1ms~1000ms	30ms	●	0x638
F6.57	DC pull in time	1ms~9999ms	1000ms	●	0x639
F6.58	Start-up frequency	0.00Hz ~ 99.00Hz	3.00Hz	●	0x63A
F6.59	Start-up frequency time	0.0sec ~ 999.0sec	3.0sec	●	0x63B
F6.60	Low frequency rising maintain frequency	0.00Hz ~ 99.00Hz	10.00Hz	●	0x63C

Torque Control Parameter Group

NO.	Function description	Range of settings and definition	Factory default	Feature	Address
F7.00	Torque given channels selection	0: keyboard number given 1: Keyboard potentiometer setting×F7.01 2: Analog VS×F7.01 3: Analog AI×F7.01 4: Analog AS×F7.01 5: Pulse PUL×F7.01 6: RS485 communication given×F7.01 7: Optional card 8: VS3(extended)	0	○	0x700
F7.01	Torque keyboard number setting	0~200.0%	100.0%	●	0x701

F7.02	Torque direction selection	<p>"0" digit: torque direction setting 0: FWD 1: REV "00" digit: torque direction change setting 0: allowed 1: banned</p>	00	●	0x702
F7.03	Output torque upper limit	F7.04~200.0%	150.0%	●	0x703
F7.04	Output torque lower limit	0~F7.03	0%	●	0x704
F7.05	Torque control FWD speed limit selection	<p>0: function code F7.07 setting 1: Keyboard potentiometer setting × F7.07 2: Analog VS × F7.07 3: Analog AI × F7.07 4: Analog AS × F7.07 5: Pulse PUL × F7.07 6: RS485 communication given × F7.07 7: Optional card 8: VS3(extended)</p>	0	●	0x705
F7.06	Torque control REV speed limit selection	<p>0: function code F7.08 setting 1: Keyboard potentiometer setting × F7.08 2: Analog VS × F7.08 3: Analog AI × F7.08 4: Analog AS × F7.08 5: Pulse PUL × F7.08 6: RS485 communication given × F7.08 7: Optional card 8: VS3(extended)</p>	0	●	0x706
F7.07	Torque control FWD speed limit	0.00~upper frequency limit	50.00Hz	●	0x707
F7.08	Torque control REV speed limit	0.00~upper frequency limit	50.00Hz	●	0x708
F7.09	Speed/torque switch delay	0.00~10.00s	0.01s	●	0x709
F7.10	Torque ACC time	0.00~10.00s	0.01s	●	0x70A
F7.11	Torque DEC time	0.00~10.00s	0.01s	●	0x70B
F7.12	FWD/REV torque dead area time	0.00~650.00s	0.00s	●	0x70C

V/F Control Parameter Group

NO.	Function description	Range of settings and definition	Factory default	Feature	Address
F8.00	V/F curve selection	0: Beeline V/F curve 1-9: 1.1-1.9 idempotent V/F curve respectively 10: square V/F curve 11: self-defined V/F curve	0	○	0x800
F8.01	Self-setting voltage V1	0.0%-100.0%	3.0%	○	0x801
F8.02	Self-setting frequency F1	0.00-max frequency	1.00Hz	○	0x802
F8.03	Self-setting voltage V2	0.0%-100.0%	28.0%	○	0x803
F8.04	Self-setting frequency F2	0.00-max frequency	10.00Hz	○	0x804
F8.05	Self-setting voltage V3	0.0%-100.0%	55.0%	○	0x805
F8.06	Self-setting frequency F3	0.00-max frequency	25.00Hz	○	0x806
F8.07	Self-setting voltage V4	0.0%-100.0%	78.0%	○	0x807
F8.08	Self-setting frequency F4	0.00-max frequency	37.50Hz	○	0x808
F8.09	Self-setting voltage V5	0.0%-100.0%	100.0%	○	0x809
F8.10	Self-setting frequency F5	0.00-max frequency	50.00Hz	○	0x80A
F8.11	Output voltage percentage	25%-100%	100%	○	0x80B
F8.12	Torque boost	0.1%~30.0%	Model set	○	0x80C
F8.13	Torque boost cut-off frequency	0.0%~100.0%	100.0%	○	0x80D
F8.14	V/F slip compensation	0.0-200.0%	0%	●	0x80E
F8.15	multi-idempotent V/F curve start frequency	0.00Hz-max frequency	10.00Hz	●	0x80F
F8.16	Surge suppression gain	0.0~10.0	5.0	●	0x810
F8.17	Surge suppression filter time	1~1000ms	50ms	●	0x811
F8.18	Over current suppression point	100%~200%	150%	●	0x812
F8.19	Over current suppression gain	0~500%	100%	●	0x813
F8.20	Over current suppression filter time	1~1000ms	20ms	●	0x814
F8.21	Reserved			●	0x815
F8.22	Reserved			●	0x816
F8.23	Auto energy saving selection	0: no operation 1: auto energy-saving running	0	○	0x817

F8.24	Energy running lower frequency limit	0.0~500.0%	25.0%	●	0x818
F8.25	Energy-saving voltage-decreasing time	0.01~50.00s	10.00s	●	0x819
F8.26	Energy-saving voltage-decreasing lower limit	20.0~100.0%	50.0%	●	0x81A

Position Control Parameter Group

NO.	Function description	Range of settings and definition	Factory default	Feature	Address
F9.00	Position control mode selection	0: not position control 1: zero servo(frequency valid) 2: zero servo(terminal valid) 3: main axis direction positioning 4: simple carry over 5: pulse row position control	0	○	0x900
F9.01	Direct completion of detection width	0~3000	10	●	0x901
F9.02	Direct completion of detection time	0~4.000sec	0.2sec	●	0x902
F9.03	Position loop gain 1	0.00~5.00	3.00	●	0x903
F9.04	Position loop gain 2	0.00~5.00	2.00	●	0x904
F9.05	0 servo start frequency	0.00Hz~20.00Hz	1.00Hz	●	0x905
F9.06	Main axis direction positioning 1	0~65535	0	●	0x906
F9.07	Main axis direction positioning 2	0~65535	0	●	0x907
F9.08	Main axis direction positioning 3	0~65535	0	●	0x908
F9.09	Main axis direction positioning 4	0~65535	0	●	0x909
F9.10	Main axis direction positioning 5	0~65535	0	●	0x90A
F9.11	Main axis direction positioning 6	0~65535	0	●	0x90B
F9.12	Main axis direction positioning 7	0~65535	0	●	0x90C
F9.13	Main axis direction positioning 8	0~65535	0	●	0x90D
F9.14	Main axis direction	0: positioning from the rotary direction	0	●	0x90E

		1: positioning from FWD direction 2: positioning from REV direction			
F9.15	Main axis positioning speed	0~50.00Hz	12.00Hz	●	0x90F
F9.16	Main axis directional DEC time	0.0~60.0sec	1.5sec	●	0x910
F9.17	Positioning location confirmation time	0.0~6.000sec	0.010sec	●	0x911
F9.18	Return origin selection	0: no action 1: action	0	○	0x912
F9.19	Return origin direction	0: FWD return origin 1: REV return origin	0	○	0x913
F9.20	Return origin frequency 1	0.00Hz~50.00Hz	10.00Hz	●	0x914
F9.21	Return origin frequency 2	0.00Hz~50.00Hz	1.00Hz	●	0x915
F9.22	Carry value 1 high position	0~9999	0	●	0x916
F9.23	Carry value 1 low position	0~9999	0	●	0x917
F9.24	Carry value 2 high position	0~9999	0	●	0x918
F9.25	Carry value 2 low position	0~9999	0	●	0x919
F9.26	Carry value 3 high position	0~9999	0	●	0x91A
F9.27	Carry value 3 low position	0~9999	0	●	0x91B
F9.28	Carry value 4 high position	0~9999	0	●	0x91C
F9.29	Carry value 4 low position	0~9999	0	●	0x91D
F9.30	Carry value 5 high position	0~9999	0	●	0x91E
F9.31	Carry value 5 low position	0~9999	0	●	0x91F
F9.32	Carry value 6 high position	0~9999	0	●	0x920
F9.33	Carry value 6 low position	0~9999	0	●	0x921
F9.34	Carry value 7 high position	0~9999	0	●	0x922
F9.35	Carry value 7 low position	0~9999	0	●	0x923

F9.36	Carry value 8 high position	0~9999	0	●	0x924
F9.37	Carry value 8 low position	0~9999	0	●	0x925
F9.38	Position given mode selection	0: Quadrature pulse given (FWD) 1: Quadrature pulse given (REV) 2: Pulse with direction, A is the pulse, B is the positive direction 3: Pulse with direction, A is the pulse, B is the negative direction	0	○	0x926
F9.39	Electronic gear ratio numerator	1~9999	1000	○	0x927
F9.40	Electronic gear ratio denominator	1~9999	1000	○	0x928
F9.41	Feed forward gain	0.000~7.000	1	●	0x929
F9.42	Feed forward filter time	0.000~7.000	0.001	●	0x92A
F9.43	Position given filter coefficient	0~9999	800	○	0x92B

Malfunction and Protection Parameter Group

NO.	Function description	Range of settings and definition	Factory default	Feature	Address
FA.00	Over voltage suppression point	110%~150%	135%	●	0xA00
FA.01	Over voltage suppression gain	0~500%	100%	●	0xA01
FA.02	Over voltage suppression filter time	1~1000ms	20ms	●	0xA02
FA.03	Reserved			●	0xA03
FA.04	Fan control	0: Fan runs after electrifying 1: Fan stop related to temperature and work when running 2: Fan stop when stop and run related to temperature	1	●	0xA04
FA.05	Reserved				0xA05
FA.06	Reserved				0xA06
FA.07	Magnetic flow braking gain	0~500%	100%	●	0xA07
FA.08	Energy braking action voltage	115.0%-140.0%	135.0%	●	0xA08
FA.09	Reserved			●	0xA09

FA.10	Bus under-voltage protection point	40.0%-100.0%	60.0%	●	0xA0A
FA.11	Output power correction coefficient	0-1000%	100%	●	0xA0B
FA.12	Power display Dimension selection	0: power display percentage (0.1%) 1: The power display kW (0.1KW)	0	●	0xA0C
FA.13	Speed tracking waiting time	0.01-60.00s	1.00	●	0xA0D
FA.14	Speed tracking frequency gain	0.00Hz - 50.00Hz	10.00Hz	●	0xA0E
FA.15	Speed tracking current gain	0.50 - 1.50	1.00	●	0xA0F
FA.16	PWM parameter setting	"0" digit: PWM mode selection 0: auto switching; 1: CPWM 2: DPWM 3: SPWM	0	●	0xA10
FA.17	Hardware current voltage protection	"0" digit: (CBC) 0: off 1: on "00" digit: hardware OV protection 0: off 1: on "000" digit: SC protection 0 - F (set 0 SC protection off) "0000" digit: current disturbing suppression 0: off 1: on	1111	●	0xA11
FA.18	Power-to-ground short-circuit detection	0: off 1: on	0	○	0xA12
FA.19	Loss phase protection	"0" digit: output loss phase protection "00" digit: input loss phase protection "000" digit: motor load loss protection 0: off 1: on	11	○	0xA13
FA.20	Motor overload pre alarm coefficient	20.0~250.0%	80.0%	●	0xA14
FA.21	Motor overload protection coefficient	20.0~250.0%	100.0%	●	0xA15
FA.22	Malfunction self recovery times	0~5	0	●	0xA16
FA.23	Malfunction self recovery interval	0.1~100.0s	1.0s	●	0xA17
FA.24	Reserved				0xA18
FA.25	Malfunction types	Please see malfunction code table	--	×	0xA19
FA.26	Malfunction running frequency	0.00-max frequency	--	×	0xA1A
FA.27	Malfunction output voltage	0-1500v	--	×	0xA1B

FA.28	Malfunction output current	0.1-2000.0A	--	×	0xA1C
FA.29	Malfunction bus voltage	0-3000V	--	×	0xA1D
FA.30	Malfunction module temperature	0-100℃	--	×	0xA1E
FA.31	Malfunction machine state	LED "0" digit: run direction 0: FWD 1: REV LED "00" digit: run state 0: stop 1: stable speed 2: ACC 3: DEC LED "000" digit: reserved LED "0000" digit: reserved	--	×	0xA1F
FA.32	Malfunction input terminal state	See input terminal chart	--	×	0xA20
FA.33	Malfunction output terminal state	See input terminal chart	--	×	0xA21
FA.34	The last malfunction types	Please see malfunction code table	--	×	0xA22
FA.35	The last malfunction running frequency	0.00-max frequency	--	×	0xA23
FA.36	The last malfunction output voltage	0-1500v	--	×	0xA24
FA.37	The last malfunction output current	0.1-2000.0A	--	×	0xA25
FA.38	The last malfunction bus voltage	0-3000V	--	×	0xA26
FA.39	The last malfunction module temperature	0-100℃	--	×	0xA27
FA.40	The last machine state	LED "0" digit: run direction 0: FWD 1: REV LED "00" digit: run state 0: stop 1: stable speed 2: ACC 3: DEC LED "000" digit: reserved LED "0000" digit: reserved	--	×	0xA28

FA.41	The last malfunction input terminal state	See input terminal chart	--	×	0xA29
FA.42	The last malfunction output terminal state	See input terminal chart	--	×	0xA2A
FA.43	The first two malfunction types	Please see malfunction code table	--	×	0xA2B
FA.44	The first three malfunction types	Please see malfunction code table	--	×	0xA2C

PID Process Control Parameter Group

NO.	Function description	Range of settings and definition	Factory default	Feature	Address
Fb.00	PID given signal source	0: Keyboard digit PID given 1: Keyboard potentiometer given 2: Terminal VS voltage analog given 3: Terminal AI analog given 4: Terminal AS current analog given 5: Terminal PUL pulse signal given 6: RS485 communication given 7: Optional card 8: Terminal selection 9: VS3 (extended)	0	○	0xB00
Fb.01	Keyboard digit given PID	0.00~100.0%	50.0%	●	0xB01
Fb.02	PID feedback signal source	0: Keyboard digit PID feedback 1: Keyboard potentiometer feedback 2: Terminal VS voltage analog feedback 3: Terminal AI analog feedback 4: Terminal AS current analog feedback 5: Terminal PUL pulse signal feedback 6: RS485 communication feedback 7: Optional card 8: Terminal selection 9: VS3 (extended)	2	○	0xB02
Fb.03	Feedback signal gain	0.00~10.00	1.00	●	0XB03
Fb.04	Feedback signal max measuring range	0~100.0	100.0	●	0xB04

Fb.05	PID control selection	LED *0*digit: feedback feature selection 0: Positive feature 1: Negative feature LED *10*digit: PID adjustment direction selection 0:reverse forbidden 1:reverse allowed LED *100*digit: alignment selection 0: not centre align 1: centre align LED *1000*digit: reserved	0100	○	0xB05
Fb.06	PID preset output	0.00~100.0%	100.0%	●	0xB06
Fb.07	PID preset output running time	0.0~6500.0s	0.0s	●	0xB07
Fb.08	Proportional gain P	0.00~100.00	1.00	●	0xB08
Fb.09	Integral time I	0.01~10.00s	0.10s	●	0xB09
Fb.10	Differential gain D	0.00~10.00s	0.00s	●	0xB0A
Fb.11	Sample cycle	0.01~100.00s	0.10s	●	0xB0B
Fb.12	PID control deviation limit	0.0~100.0%	0.0%	●	0xB0C
Fb.13	Reserved				0xB0D
Fb.14	Feedback wire break detection time	0.0~120.0s	1.0s	●	0xB0E
Fb.15	Feedback wire break action selection	0: Go on PID operation without alarm 1: Stop and alarm malfunction 2: Go on PID operation and output alarm signal 3: Run at the current frequency and output alarm signal	0	●	0xB0F
Fb.16	Wire break alarm upper limit	0.0~100.0%	100.0%	●	0xB10
Fb.17	Wire break alarm lower limit	0.0~100.0%	0.0%	●	0xB11

Multi-Speed, PLC Function and Swing Frequency Parameter Group

NO.	Function description	Range of settings and definition	Factory default	Feature	Address
FC.00	PLC Speed 1	0.00-320.00Hz	10.00Hz	●	0xC00
FC.01	PLC Speed 2	0.00-320.00Hz	20.00Hz	●	0xC01
FC.02	PLC Speed 3	0.00-320.00Hz	30.00Hz	●	0xC02
FC.03	PLC Speed 4	0.00-320.00Hz	40.00Hz	●	0xC03
FC.04	PLC Speed 5	0.00-320.00Hz	50.00Hz	●	0xC04
FC.05	PLC Speed 6	0.00-320.00Hz	40.00Hz	●	0xC05

FC.06	PLC Speed 7	0.00-320.00Hz	30.00Hz	●	0xC06
FC.07	PLC Speed 8	0.00-320.00Hz	20.00Hz	●	0xC07
FC.08	PLC Speed 9	0.00-320.00Hz	10.00Hz	●	0xC08
FC.09	PLC Speed 10	0.00-320.00Hz	20.00Hz	●	0xC09
FC.10	PLC Speed 11	0.00-320.00Hz	30.00Hz	●	0xC0A
FC.11	PLC Speed 12	0.00-320.00Hz	40.00Hz	●	0xC0B
FC.12	PLC Speed 13	0.00-320.00Hz	50.00Hz	●	0xC0C
FC.13	PLC Speed 14	0.00-320.00Hz	40.00Hz	●	0xC0D
FC.14	PLC Speed 15	0.00-320.00Hz	30.00Hz	●	0xC0E
FC.15	PLC running mode selection	LED*0*digit: cycle mode 0: Stop after single cycle 1: Continuous cycles 2: Keep final value after single cycle LED*00*digit: Time unit 0: second 1: minute 2: hour LED*000*digit: Power down memory mode 0: not saved 1: save LED*0000*digit: Start-up mode 0: Restart from the 1st stage 1: Restart from the stop stage 2: Continue from the time when stop	0000	●	0xC0F
FC.16	PLC 1st Step running time	0.0-6500.0(s/m/h)	10.0	●	0xC10
FC.17	PLC 2nd Step running time	0.0-6500.0(s/m/h)	10.0	●	0xC11
FC.18	PLC 3rd Step running time	0.0-6500.0(s/m/h)	10.0	●	0xC12
FC.19	PLC 4th Step running time	0.0-6500.0(s/m/h)	10.0	●	0xC13
FC.20	PLC 5th Step running time	0.0-6500.0(s/m/h)	10.0	●	0xC14
FC.21	PLC 6th Step running time	0.0-6500.0(s/m/h)	10.0	●	0xC15
FC.22	PLC 7th Step running time	0.0-6500.0(s/m/h)	10.0	●	0xC16
FC.23	PLC 8th Step running time	0.0-6500.0(s/m/h)	10.0	●	0xC17
FC.24	PLC 9th Step running time	0.0-6500.0(s/m/h)	10.0	●	0xC18
FC.25	PLC 10th Step running time	0.0-6500.0(s/m/h)	10.0	●	0xC19

FC.26	PLC 11th Step running time	0.0-6500.0(s/m/h)	10.0	●	0xC1A
FC.27	PLC 12th Step running time	0.0-6500.0(s/m/h)	10.0	●	0xC1B
FC.28	PLC 13th Step running time	0.0-6500.0(s/m/h)	10.0	●	0xC1C
FC.29	PLC 14th Step running time	0.0-6500.0(s/m/h)	10.0	●	0xC1D
FC.30	PLC 15th Step running time	0.0-6500.0(s/m/h)	10.0	●	0xC1E
FC.31	PLC 1st Step direction and ADD/DEC time	<p>LED "0" digit: this step run direction 0: FWD 1: REV LED "00" digit: ACC/DEC time in this step 0: ACC/DEC time 1 1: ACC/DEC time 2 2: ACC/DEC time 3 4: ACC/DEC time 4 LED "000" digit: reserved LED "0000" digit: reserved</p>	0000	●	0xC1F
FC.32	PLC 2nd Step direction and ADD/DEC time		0000	●	0xC20
FC.33	PLC 3rd Step direction and ADD/DEC time		0000	●	0xC21
FC.34	PLC 4th Step direction and ADD/DEC time		0000	●	0xC22
FC.35	PLC 5th Step direction and ADD/DEC time		0000	●	0xC23
FC.36	PLC 6th Step direction and ADD/DEC time		0000	●	0xC24
FC.37	PLC 7th Step direction and ADD/DEC time		0000	●	0xC25
FC.38	PLC 8th Step direction and ADD/DEC time		0000	●	0xC26
FC.39	PLC 9th Step direction and ADD/DEC time		0000	●	0xC27
FC.40	PLC 10th Step direction and ADD/DEC time		0000	●	0xC28
FC.41	PLC 11th Step direction and ADD/DEC time		0000	●	0xC29
FC.42	PLC 12th Step direction and ADD/DEC time		0000	●	0xC2A

FC.43	PLC 13th Step direction and ADD/DEC time		0000	●	0xC2B
FC.44	PLC 14th Step direction and ADD/DEC time		0000	●	0xC2C
FC.45	PLC 15th Step direction and ADD/DEC time		0000	●	0xC2D
FC.46	Reserved				0xC2E
FC.47	Reserved				0xC2F
FC.48	Reserved				0xC30
FC.49	Swing frequency control	LED "0" digit: swing frequency control 0: invalid 1: valid LED "00" digit: swing frequency input mode 0: auto 1: manual LED "000" digit: amplitude control 0: variable amplitude 1: fixed amplitude LED "0000" digit: reserved	0000	○	0xC31
FC.50	Preset swing frequency	0.00~Max frequency	0.00Hz	●	0xC32
FC.51	Preset frequency lasting time	0.00~650.00s	0.00s	●	0xC33
FC.52	Swing frequency amplitude	0.0~100.0%	0.0%	●	0xC34
FC.53	Startup frequency amplitude	0.0~50.0%	0.0%	●	0xC35
FC.54	Swing frequency rising time	0.00~650.00s	5.00s	●	0xC36
FC.55	Swing frequency falling time	0.00~650.00s	5.00s	●	0xC37

Communication Control Function Parameter Group

NO.	Function description	Range of settings and definition	Factory default	Feature	Address
Fd.00	Main-slave machine Selection (Modbus and CAN)	LED "0" digit: Modbus main-slave machine selection LED "00" digit: CAN main-slave machine selection 0: Main machine 1: Slave machine	0000	○	0xD00

Fd.01	Modbus communication slave address	1~247	1	○	0xD01
Fd.02	Communication baud rate selection	LED "0" digit: Modbus communication: 0: 1200 bps 1: 2400 bps 2: 4800 bps 3: 9600 bps 4: 19200 bps 5: 38400 bps LED "00" digit: CAN communication:1: 0: 20 kbps 1: 50 kbps 2: 100kbps 3: 125kbps 4: 250kbps 5: 500kbps 6: 1Mbps	0043	○	0xD02
Fd.03	Modbus data format	0: (N,8,1) no checkout, Data digit: 8, Stop digit: 1 1: (E,8,1) even checkout, Data digit: 8, Stop digit: 1 2: (O,8,1) odd checkout, Data digit: 8, Stop digit: 1 3: (N,8,2) no checkout, Data digit: 8, Stop digit: 2 4: (E,8,2) even checkout, Data digit: 8, Stop digit: 2 5: (O,8,2) odd checkout, Data digit: 8, Stop digit: 2	0	○	0xD03
Fd.04	Communication ratio setting	0.00~5.00	1.00	●	0xD04
Fd.05	Modbus communication answer delay	0~500ms	0ms	●	0xD05
Fd.06	Modbus communication overtime time	0.1~100.0s	1.0s	●	0xD06
Fd.07	Modbus communication fault action mode selection	0: Alarm and stop freely 1: Not alarm, go on running 2: Stop without alarm 3: Stop without alarm (running given by channels)	1	●	0xD07
Fd.08	Modbus transmission response dispose	0: Write operation with response 1: Write operation without response	0	●	0xD08

Fd.09	Main machine sending selection	<p>LED*0*digit: the first group transmitting frame selection 0: Invalid 1: Run command given 2: Main machine given frequency 3: Main machine output frequency 4: Main machine upper limit frequency 5: Main machine given torque 6: Main machine output torque 7: Torque control FWD speed limit 8: Torque control REV speed limit 9: Main machine given PID A: Main machine feedback PID B: voltage frequency voltage command given</p> <p>LED*10*digit: the second group transmitting frame selection Same as above</p> <p>LED*100*digit: the third group transmitting frame selection Same as above</p> <p>LED*1000*digit: the fourth group transmitting frame selection Same as above</p>	0031	●	0xD09
Fd.10	RS485 communication port configuration	0: Modbus communication 1: serial ports monitoring 2: reserved	0	○	0xD0A
Fd.11	CAN communication protocol selection	0: CANOpen protocol 1: CAN self defined protocol 2: CAN oscilloscope protocol	0	○	0xD0B
Fd.12	CAN communication slave address	0~127	1	○	0xD0C
Fd.13	CAN main machine transmitting selection	<p>LED*0*digit: the first group transmitting frame selection 0: Invalid 1: Run command given 2: Main machine given frequency 3: Main machine output frequency 4: Main machine upper limit frequency 5: Main machine given torque 6: Main machine output torque 7: Torque control FWD speed limit 8: Torque control REV speed limit 9: Main machine given PID A: Main machine feedback PID B: voltage frequency voltage command given</p>	0031	●	0xD0D

Fd.13	CAN main machine transmitting selection	LED*10"digit: the second group transmitting frame selection Same as above LED*100"digit: the third group transmitting frame selection Same as above LED*1000"digit: the fourth group transmitting frame selection Same as above	0031	●	0xD0D
-------	---	--	------	---	-------

Monitor Code

Access 'C' parameter group by pressing 'PRG' for more than 2s; check out the current state of inverter.

NO.	Function name	Range of settings and definition	Address
C-00	Given frequency	0.01Hz	2100H
C-01	Output frequency	0.01Hz	2101H
C-02	Output current	0.1A	2102H
C-03	Input voltage	0.1V	2103H
C-04	Output voltage	0.1V	2104H
C-05	Machine speed	RPM	2105H
C-06	Synchronizing frequency	0.1%	2106H
C-07	Output torque	0.1%	2107H
C-08	PID given value	0.1%	2108H
C-09	PID feedback value	0.1%	2109H
C-10	Output power	0.1%	210AH
C-11	Bus voltage	0.1V	210BH
C-12	Module temperature 1	0.1°C	210CH
C-13	Module temperature 2	0.1°C	210DH
C-14	Input terminal X on-off state	refer to input terminal diagram	210EH
C-15	Output terminal Y on-off state	refer to output terminal diagram	210FH
C-16	Analog VS input value	0.001V	2110H
C-17	Analog AI input value	0.001V	2111H
C-18	Analog AS input value	0.001mA	2112H
C-19	Impulse single PUL input	0.001kHz	2113H
C-20	Analog output AO1	0.01V	2114H
C-21	Analog output AO2	0.01V/0.01mA/0.01kHz	2115H
C-22	Counting value of counter		2116H
C-23	Running time after electrifying	0.1h	2117H
C-24	Local accumulative running time	Hour	2118H

C-25	Inverter power class	kW	2119H
C-26	Inverter rated voltage	V	211AH
C-27	Inverter rated current	A	211BH
C-28	Software version		211CH
C-29	PG feedback frequency	0.01Hz	211DH
C-30	Extended input X terminal on-off state	refer to input terminal diagram	211EH
C-31	Extended output Y terminal on-off state	refer to output terminal diagram	211FH
C-32	Extended VS3 input value	-10.00V ~ +10.00V	2120H
C-33	Reserved		2121H
C-34	Reserved		2122H
C-35	Counted time of timer	sec/min/h	2123H
C-36	Output current	0.01A	2124H
C-37	Total power consumption (low position)	1	2125H
C-38	Total power consumption (high position)	10000	2126H
C-39	Power factor angle	1°	2127H
C-40	Synchronous open loop output voltage regulation	1V	2128H
C-41	Excitation current	1	2129H
C-42	Torque current	1	212AH
C-43	Overload coefficient of inverter	1~100.0%	212BH
C-44	Overload coefficient of motor	1~100.0%	212CH
C-45	Speed tracking signal frequency	0.01Hz	212DH
C-46	Number of Z signal	1	212EH
C-47	Rotor magnetic field vector phase	0~360.0°	212FH
C-48	Spin AD diagnose signal	1x1	2130H
C-49	Fault diagnose information	See fault code	2131H

Input Terminal on/off State Diagram:

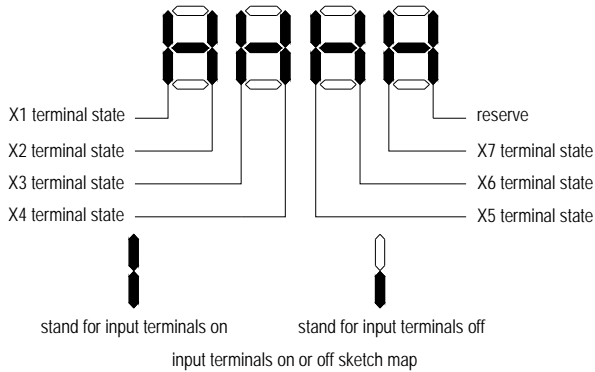

Tip: connection diagrams of C-30 monitor expansion input terminals X8 - X10 are the same as above, but only displaying the first three valid.

Output Terminal on/off State Diagram:

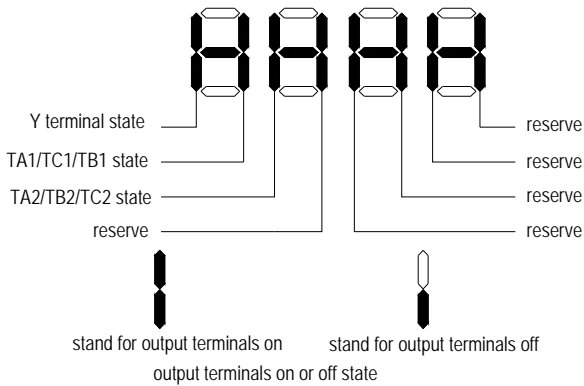

Tip: connection diagrams of C-31 monitor expansion output relay TA3-TC3 and TA4-TC4 are the same as above, but only displaying the first two valid.

9.2 Appendix 2: RS485 Communication Protocol

● Introduction

The AC100 series frequency inverter is equipped with the RS485 communication interface and the ModBus communication protocol of international standard is adopted for master-slave communication. Users can realize centralized control by PC/PLC, upper machine, mAC80Cn station frequency inverter etc (Setting of the frequency inverter control command, running frequency, relative function parameters modification, frequency inverter working state and malfunction information monitoring etc.) to adapt to specific application requirements.

● Application Methods

1. AC100 series frequency inverter is connected to "single host and multi slave machines" control network with RS485 master line. Slave machine do not response when host machine order with broadcast (slave machine address is 0).
2. AC100 only provides RS485 interface, asynchronous half-duplex. When the communication interface of the external equipment is RS232, RS232/RS485 converter should be added.
3. This ModBus serial communication protocol defines the asynchronous transfer information content and formats used in the serial communication, which can be divided into RTU and ASCII mode. AC100 is RTU (remote terminal unit) mode.

● Communication Frame Structure

Communication data format is as follows:

The byte composition: Including initiation bit, 8 data bit, check bit and stop bit.

Initiation Bit	Bit1	Bit2	Bit3	Bit4	Bit5	Bit6	Bit7	Bit8	Check bit	Stop bit
----------------	------	------	------	------	------	------	------	------	-----------	----------

One frame message must be transmitted as a continued data flow, and if there is a interval over 1.5 byte before ending, the receiving equipment will clear the half-baked information. And the next byte will be considered as the address field of a new frame. Similarly, if the interval between a new frame start-up and the former frame is smaller than 3.5 byte time, the receiving equipment will consider that it is the continuation of former one frame. Since the jumbled frame, the final CRC checking value is incorrect, which would lead to the communication mistake.

Standard Structure of RTU Frame:

Frame Start	Transmission time of 3.5 bytes
Slave machine address	Communication address: 0~247 (decimal) (0 is the broadcast address)
Command code	03H: read slave machine parameter 06H: write slave machine parameter 08H: circuit auto-detection
Data area	parameter address, parameter number, parameter values
CRC CHK low-order	Detecting value: 16 bit CRC Detecting value
CRC CHK high-order	
Frame ending	transmission time of 3.5 bytes

In RTU mode, it always begins with transmission time pause gap of at least 3.5 bytes. The successive order of the following transmission data domains: slave machine address、operation command code, data and CRC checking bit. Transmission byte of each domain is hexadecimal 0...9, A...F. Network equipment detects the network bus unceasingly, including the pause gap time. When receiving the first domain (address information), each network equipment would carry out decoding to judge whether the byte is sent to itself. When the final byte transmission is completed, there will be an at least 3.5 bytes transmission time pause gap to indicate that this frame is over. Then a new information transmission can start.

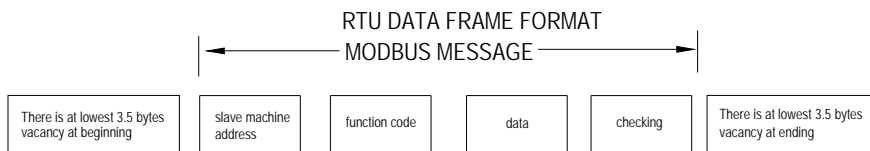

● Command Code and Communication Data Description

Command code: 03 H, read N words (Word), continuously read five words at most.

For example: The frequency inverter whose slave machine address is 01 H, memory initial address is 2100H [(C-00)], read continuously 3 words, then the structure of that frame is described as follows:

RTU host machine command information

START	Transmission time of 3.5 bytes
Slave machine address	01H
Command code	03H
Start address high-order	21H
Start address low-order	00H
Data number high-order	00H
Data number low-order	03H
CRC CHK low-order	0FH
CRC CHK high-order	F7H
END	Transmission time of 3.5 bytes

RTU Slave Machine Responding Information (normal)

START	Transmission time of 3.5 bytes
Slave machine address	01H
Command code	03H
Byte number low-order	06H
Data address 2100H high-order	13H
Data address 2100H low-order	88H
Data address 2101H high-order	00H
Data address 2101H low-order	00H
Data address 2102H high-order	00H
Data address 2102H low-order	00H
CRC CHK low-order	90H
CRC CHK high-order	A6H
END	Transmission time of 3.5 bytes

Slave Machine Responding Information (abnormal)

START	Transmission time of 3.5 bytes
Slave machine address	01H
Command code	03H
Error code	04H
CRC CHK low-order	21H
CRC CHK high-order	33H
END	Transmission time of 3.5 bytes

Command code: 06H, write a word (Word)

Function: write a word data in the designated data address. It can be used to revise the frequency inverter parameters.

For instance: 5000 (1388 H) is written into the 3000H address of slave frequency inverter with address 1. Then the structure of this frame is described as follows:

RTU Host Machine Order Information

START	Transmission time of 3.5 bytes
Slave machine address	01H
Command code	06H
Write data address high-order	30H
Write data address low-order	00H
Data content high-order	13H
Data content low-order	88H
CRC CHK low-order	8BH
CRC CHK high-order	9CH
EBD	Transmission time of 3.5 bytes

RTU Slave Machine Responding Information (normal)

START	Transmission time of 3.5 bytes
Slave machine address	01H
Command code	06H
Write data address high-order	30H
Write data address low-order	00H
Data content high-order	13H
Data content low-order	88H
CRC CHK low-order	8BH
CRC CHK high-order	9CH
EBD	Transmission time of 3.5 bytes

RTU Slave Machine Responding Information (abnormal)

START	Transmission time of 3.5 bytes
Slave machine address	01H
Command code	86H
Error code	01H
CRC CHK low-order	83H
CRC CHK high-order	A0H
END	Transmission time of 3.5 bytes

Command code: 08H, circuit auto-detection

Function: Send back the responding information of slave machine which is identical with the host machine command information. It is used to check whether the signal transmission between the host machine and slave machine is normal or not. The checking code and the data can be set freely.

RTU Host Machine Command Information

START	Transmission time of 3.5 bytes
Slave machine address	01H
Command code	08H
Detecting code high-order	00H

Detecting code low-order	00H
Data high-order	13H
Data low-order	88H
CRC CHK low-order	EDH
CRC CHK high-order	5DH
END	Transmission time of 3.5 bytes

RTU Slave Machine Responding Information (normal)

START	Transmission time of 3.5 bytes
Slave machine address	01H
Command code	08H
Detecting code high-order	00H
Detecting code low-order	00H
Data high-order	13H
Data low-order	88H
CRC CHK low-order	EDH
CRC CHK high-order	5DH
END	Transmission time of 3.5 bytes

RTU Slave Machine Responding Information (abnormal)

START	Transmission time of 3.5 bytes
slave machine address	01H
Command code	88H
Error code	03H
CRC CHK low-order	06H
CRC CHK high-order	01H
END	Transmission time of 3.5 bytes

Communication frame error check mode

The standard MODBUS serial network adopts two kinds of error check mode: odd/even checking which is used to check every character and CRC detecting which is used to check one frame data.

1. Odd-even Checking

Users can configure the controller with odd or even checking, or no checking, which will affect the setting of odd/even checking in every character.

If odd/even checking has been specified, "1" bit will be accounted to the bit number of each character (7 bits in ASCII mode, 8 bits in RTU). For instance, the RTU character frame contains the following 8 bits: 1 1 0 0 0 1 0 1

There are 4 bits with number"1". If using the even checking, odd/even checking bit of the frame will be 0, then there are still 4 bits with number"1". If using odd checking, odd/even checking bit of the frame will be 1, then there are 5 bits with number"1".

If odd/even checking has not been specified, there will be no checking bit during the transmission, and no checking detection. One additional stop bit will be filled into the character frame in transmission.

2. CRC-16 (cycle redundant checking)

When the RTU frame form in use; the frame has included the frame error detecting domain which calculates base on the CRC method. The CRC domain checks the content of the entire frame. The CRC domain is two bytes, containing binary values of 16 bits. It is added to the frame after calculated by the transmission equipment. The receiving

equipment calculates CRC who receives frame again, and compares it with the value of the receiving CRC domain. If both CRC value are not equal, it means the transmission is wrong.

CRC is firstly stored in 0xFFFF. Then a program is used to process the continuous 6 or above bytes in the frame and the value of current registers. Only 8 Bit in every character is valid to CRC. Start bit, stop bit and parity check bit are invalid.

In the producing process of CRC, each 8 characters independently XOR with register content. The result moves to the lowest effective bit, and then the highest effective bit is filled by "1". LSB is extracted to be detected. If LSB is 1, the register independently XOR with the present value; If LSB is 0, XOR is not needed. This entire process needs to repeat for 8 times. After the last bit (the eighth bit) is accomplished, next 8 bits byte will independently XOR with register content. All the final bytes in the frame are CRC value after processing.

This CRC calculation method adopts the international standard CRC checking rule. Users can consult the relevant standard CRC operation when editing the CRC algorithm to compile required CRC calculation program.

Now here provide the user a simple CRC operation function (C language programming):

```
unsigned int crc_chk_value(unsigned char *data_value, unsigned char length)
```

```
{
    unsigned int crc_value=0xFFFF;
    int i;
    while(length--)
    {
        crc_value^=*data_value++;
        for(i=0;i<8;i++)
        {
            if(crc_value&0x0001)
            {
                crc_value=(crc_value>>1)^0xa001;
            }
            else
            {
                crc_value=crc_value>>1;
            }
        }
    }
    return(crc_value);
}
```

●Communication Data Address Definition

This part is about the address definition of communication data, used to control the frequency inverter running and obtain the mode information and relevant function parameter setting of the frequency inverter.

(1)AC100 Series Function Parameter Address Expressing Rules

Take the frequency inverter function parameter serial numbers as the register address which are divided into the high byte and the low byte. The high byte represents the function parameter group serial numbers. The low byte represents the inner serial numbers of each function parameter group. All need to be changed to hexadecimal.

High byte definition of address domain:

Parameter Code No	Head Address of This Group Parameter
F0 basic parameter group	0x0000 (not saved in to EEPROM) 0x1000 (saved in to EEPROM)
F1 running control parameter group	0x0100 (not saved in to EEPROM)

	0x1100 (saved in to EEPROM)
F2 quantum digital terminal parameter group	0x0200 (not saved in to EEPROM) 0x1200 (saved in to EEPROM)
F3 quantum analog terminal parameter group	0x0300 (not saved in to EEPROM) 0x1300 (saved in to EEPROM)
F4 keyboard and display parameter group	0x0400 (not saved in to EEPROM) 0x1400 (saved in to EEPROM)
F5 motor parameter group	0x0500 (not saved in to EEPROM) 0x1500 (saved in to EEPROM)
F6 VC control parameter group	0x0600 (not saved in to EEPROM) 0x1600 (saved in to EEPROM)
F7 torque control parameter	0x0700 (not saved in to EEPROM) 0x1700 (saved in to EEPROM)
F8 V/F control parameter group	0x0800 (not saved in to EEPROM) 0x1800 (saved in to EEPROM)
F9 reserved	0x0900 (not saved in to EEPROM) 0x1900 (saved in to EEPROM)
FA malfunction protection parameter group	0x0A00 (not saved in to EEPROM) 0x1A00 (saved in to EEPROM)
Fb PID control parameter group	0x0B00 (not saved in to EEPROM) 0x1B00 (saved in to EEPROM)
FC multi velocity and PLC parameter group	0x0C00 (not saved in to EEPROM) 0x1C00 (saved in to EEPROM)
Fd communication control parameter group	0x0D00 (not saved in to EEPROM) 0x1D00 (saved in to EEPROM)
FE reserved	0x0E00 (not saved in to EEPROM) 0x1E00 (saved in to EEPROM)
FF reserved	0x0F00 (not saved in to EEPROM) 0x1F00 (saved in to EEPROM)
C monitor parameter group	0x2100
Communication control parameter group	0x3000 or 0x2000

Note: since it is inevitable that the parameters are frequently rewritten during the communication, the lifetime of EEPROM would be shortened if frequently stored. As for the users, some functions are unnecessary to store in the communication mode, only changing the value of RAM inner value can satisfy the required use. When AC100 communication protocol stipulates to use writing command (06 H), if the parameter function code address domain's highest digit is 0, it only write in the RAM of the frequency inverter, and power down without storage; if the parameter function code address high half digit is 1, it write in EEPROM, which means power off storage.

For instance, when rewriting the function parameter [F0.14], if not depositing to EEPROM, address expresses for 000EH; if depositing to EEPROM, address expresses for 100EH.

(2)Communication Control Parameter Group Address Specification:

Function Specification	Address Definition	Data Meaning Specification	R/W Characteristic
Communication Given	0x3000 or	0~32000 is corresponding to	W/R

Frequency	0x2000	0.00Hz~320.00Hz			
Communication Order Setting	0x3001 or 0x2001	0000H: No order		W/R	
		0001H: FWD running			
		0002H: REV running			
		0003H: FWD jog			
		0004H: REV jog			
		0005H: speed-down stop			
		0006H: freely stop			
State of Inverter	0x3002 or 0x2002	Bit0	0: stop	1: running	R
		Bit1	0: non-accelerating	1: ACC	
		Bit2	0: non-decelerating	1: DEC	
		Bit3	0: Forward	1: REV	
		Bit4	0: normal	1: fault	
Frequency Inverter Fault Code	0x3003 or 0x2003	current inverter fault code (refer to fault code table)		R	
Communication Given Upper Frequency	0x3004 or 0x2004	0~32000 is corresponding to 0.00Hz~320.00Hz		W/R	
Communication Given Torque Setting	0x3005 or 0x2005	0~1000 is corresponding to 0.0~100.0%		W/R	
Communication Given Max Frequency in Torque Control FWD	0x3006 or 0x2006	0~1000 is corresponding to 0.0~100.0%		W/R	
Communication Given Max Frequency in Torque Control REV	0x3007 or 0x2007	0~1000 is corresponding to 0.0~100.0%		W/R	
Communication Given PID Setting	0x3008 or 0x2008	0~1000 is corresponding to 0.0~100.0%		W/R	
Communication Given PID Feedback	0x3009 or 0x2009	0~1000 is corresponding to 0.0~100.0%		W/R	
Voltage Frequency separation voltage value setting	0x300A or 0x200A	0~1000 is corresponding to 0.0~100.0%		W/R	

List of fault code meanings for abnormal response information from slave machine:

Fault Code	Meanings
1	Order code fault
2	Reserved
3	CRC not correct
4	Address not correct
5	Data not correct

6	Unable to modify when running
7	Reserved
8	Inverter busy (EEPROM is storing)
9	Value over limit
10	Reserved parameters can't be modify
11	Number of Bytes wrong when reading

9.3 Appendix 3: PG Card Manual

1. Overview

AC100 is equipped with various feedback cards that are mainly used for VC frequency inverter (AC100 series) feedback of motor speed and direction detection signal to achieve higher accuracy of motor speed and direction control. Please select the corresponding PG card according to the encoder.

2. Types and Selections of PG Card

There're 2 types of PG card: incremental encoder PG card and rotary transformer PG card. Encoder input signal type and feedback card output signal type are as follows:

Type	Support input signal type	Type of PG output signal:	Suitable motor type
Incremental encoder PG	1.Difference signal input 2.Open collector circuit input 3.Push-pull signal input	1.Open collector circuit input(frequency division / no division) 2.Difference signal output(frequency division / no division)	AM
Rotary transformer PG	Rotary transformer signal input	None	AM/PM

3. Order Model

Order Model Instructions

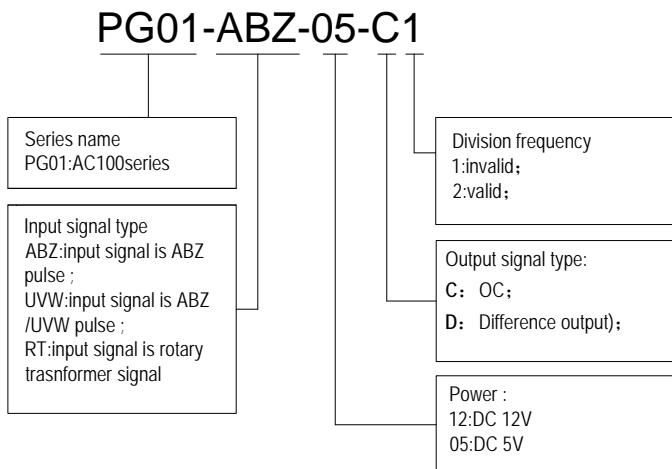

Order Information:

- 1) The power supply of domestic encoders are usually 5V or 12V, while foreign encoders are usually 5V, please select the appropriate power supply based on the encoder type.
- 2) Resolution is the number of output pulses of the encoder per cycle, which must meet the designing precision requirements. Please choose the right power supply based on encoder mode.
- 3) please choose the PG card output signal receiving device based on the actual demands, such as monitoring equipment can be selected PLC OC output type, and differential output type can be chosen for other special

equipments that has anti-interference requirement.

Note:

1)Incremental encoder PG card recommended order model :PG01-ABZ-05-C1, please refer to Ordering Information if there's other demand.

2) Rotary encoder PG card recommended order model: PG01-RT; please refer to Ordering Information if there's other demand.

4. Incremental Encoder PG Card Instruction

4.1 Product Technical Parameter

Power	Characteristic of Input Signal			Characteristic of Output Signal	
	Input signal	Respond frequency range	Input impedance	Output frequency range	Output current
5V/12V±5% 200mA	A B Z	0~300KHz	About 1000Ω	1-open collector circuit output: 0~80KHz 2-Difference signal output: 0~300KHz	≤100mA
	U V W	0~100KHz			

4.2 Terminal Function Instruction

Terminals array of incremental encoder PG card is shown as follows:

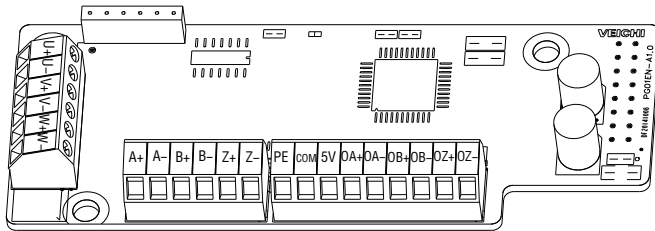

4.3 Main Signal Terminals Function Instruction

Terminal definition	Terminal name	Instruction
Power	5/12V	Maximum current output 200mA
	PE	Ground
Common terminal	COM	Power earth
Output side of PG	OA+	Difference output A signal (reused as A signal when open collector circuit output)
	OA-	Difference output A signal
	OB+	Difference output B signal (reused as B signal when open collector circuit output)
	OB-	Difference output B signal
	OZ+	Difference output Z signal
	OZ-	Difference output Z signal

Input side of encoder	A+	Encoder A differential signal input (push-pull and open collector circuit output both compatible)
	A-	
	B+	Encoder B differential signal input (push-pull and open collector circuit output both compatible)
	B-	
	Z+	Encoder Z differential signal input (push-pull and open collector circuit output both compatible)
	Z-	
	U+	Encoder U differential signal input (push-pull and open collector circuit output both compatible)
	U-	
	V+	Encoder V differential signal input (push-pull and open collector circuit output both compatible)
	V-	
	W+	Encoder W differential signal input (push-pull and open collector circuit output both compatible)
	W-	

1. Input signals of A+, A-, B+, B- are two groups of orthogonal pulses. A group consists of opposite signals A+ and A-. B group consists of opposite signals B+ and B-. Group A and group B are orthogonal respectively. The function is the same as open collector circuit and push-pull encoder.

2. Input terminal Z+, Z- are zero position signals, which is the pulse signal encoder will give each circle.

3. Input signals U+, U-, V+, U-, W+, W- are PM position detecting signals. The phase difference of the three groups is 120°.

Note: Terminals OA+, OB- are reused as open collector circuit encoder input signals. But the open collector signals can't be chosen with the differential output signal at the same time.

4.4 Switch Terminals Instruction

There're 8 bits in switch terminal and the switch is used as PG division frequency ratio. Ratio of division frequency is equal to 2 multiply binary system numbers the switch terminals stand for. Switch ON means invalid, OFF means valid. Examples are shown as follows:

PG card output signal frequency selection terminal	CON4		$f_o=f_i$
			$f_o=f_i/2$
			$f_o=f_i/4$
			$f_o=f_i/6$

		...	
			$f_o=f_i/508$
			$f_o=f_i/510$

4.5 Related Parameters Settings

Please set parameters according to actual needs. Related parameters are listed as follows:

Function code	Name
F0.00	Control mode
F5.15	Type of rotary encoder
F5.16	Numbers of pulse every circle

4.6 Wiring Precautions

- 1, PG card signal lines and power lines should be separated; no parallel wiring.
- 2, To avoid the encoder signal interference, please use shielded cable as the signal line of PG card.
- 3, The encoder shielded cable should be connected to the ground (or the inverter PE terminal), single-grounded is even better to avoid signal interference.

4.7 Overall Wiring Diagram

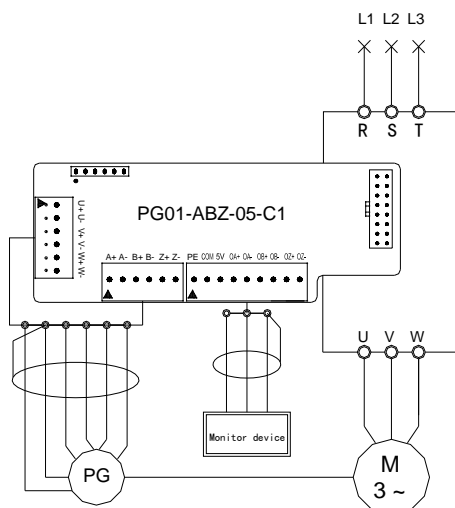

4.8 Application wiring

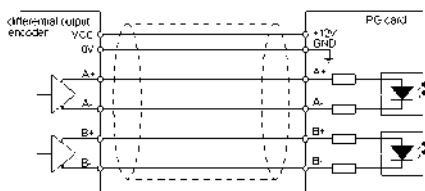

Differential Output Encoder Wiring

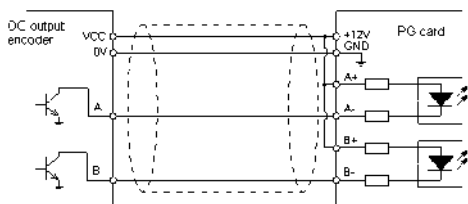

Open Collector Output Encoder Wiring

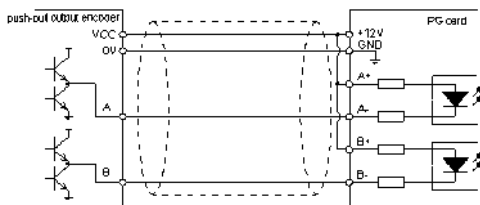

Push-pull Output Encoder Wiring

5. Rotary Transformer PG Card Instruction

5.1 Function Instruction

Output signals of rotary transformer are two phase orthogonal analog signals. Their amplitudes is changing as sine and cosine curve following angle. The frequency and the exciting frequency are in consistency.

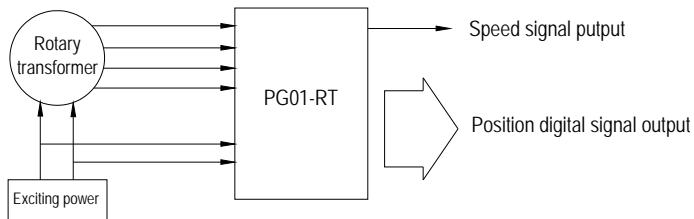

5.2 Instruction of Terminals Function

Terminals array of rotary transformer PG is shown as follows:

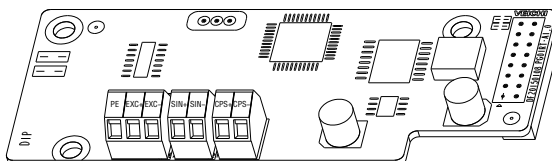

5.3 Main Signal Terminal Instruction

Terminals definition	Terminals name	Instruction
output	PE	Earth
	EXC+	Driving source output
	EXC-	Driving source output
input	COS+	Cosine signals input
	COS-	
	SIN+	Sine signals input
	SIN-	

The excitation of rotary transformer and SIN/COS feedback waveform are shown as follows; Enveloping lines of sine and cosine have the same frequency as exciting frequency

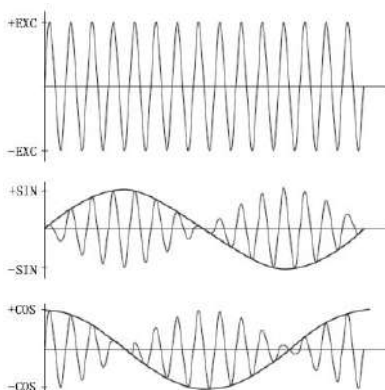

5.4 Overall Wiring

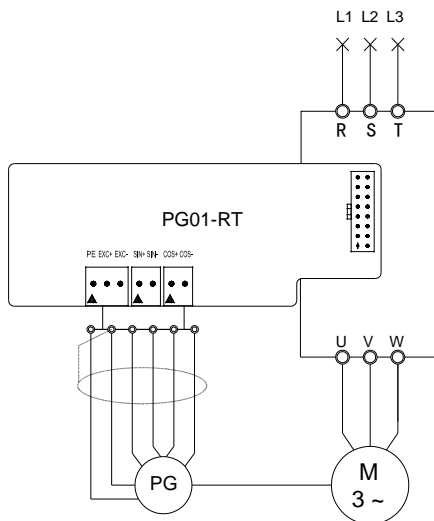

5.5 Wiring Precautions

- 1, PG card signal lines and power lines should be separated; no parallel wiring.
- 2, To avoid the encoder signal interference, please use shielded cable as the signal line of PG card.
- 3, The encoder shielded cable should be connected to the ground (or the inverter PE terminal), single-grounded is even better to avoid signal interference.

6. Installation and Dimension

6.1 Installation Drawing

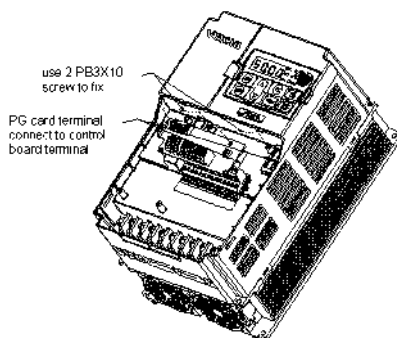

6.2 Installation Dimension

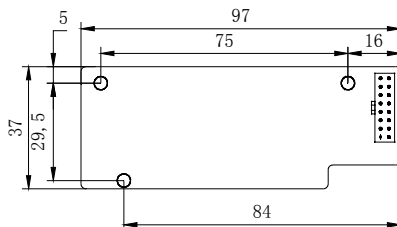

9.4 Appendix 4: Profibus-DP card manual

1 Profibus-DP Card Installation

Before installing please switch off power supply, and wait 10 minutes after the power supply indicators LED goes off. Embed the Profibus-DP card to the inside of inverter, which is under the removable cover. See in Fig. 1-1.

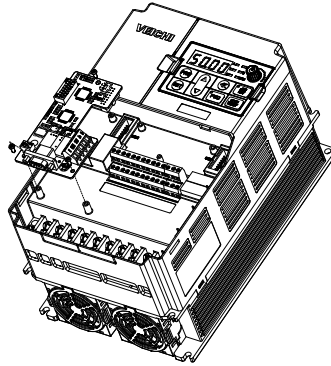

Fig.1-1 Profibus-DP Card Installation Method

2 Profibus-DP Card I/O Interface Specification

2.1 Product Mode Specification

Product Model	Product Specification	Detail
ACDP03	AC100 standard Profibus-DP extension parts	5V ± 5%/ specific interface
ACDP04	General Profibus-DP extension parts	24V ± 10%/out-sourcing connection line

2.2 Products Connection Schematic Diagram

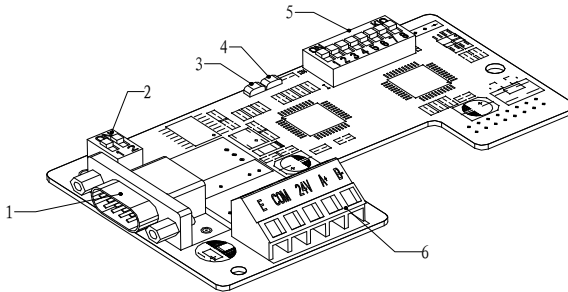

Fig. 2-2ACDP04 connection

- 1: Profibus-DP interface
- 2: Inside terminal resistor selecting slide switch
- 3: Indicator LED D1
- 4: Indicator LED D2
- 5: Profibus-DP slave address slid switch
- 6: interface for ACDP03 and AC100 inverter
- 7: interface for ACDP04 and slave machine

3. Wiring

Profibus-DP adopts RS-485 physical transmission method. Please wiring with Profibus-DP standard cable to ensure stable and reliable communication system. The relation of the transmission rate selecting of Profibus-DP standard cable between allowable maximum length are shown in the diagram below:

Bus speed rate	9.6	19.2	93.75	187.5	500	1500	6000	12000
Length of cable A (m)	1200	1200	1200	1000	400	200	100	100
Length of cable B (m)	1200	1200	1200	600	200	100	100	100

Profibus-DP Standard Connector; See in Fig 3-1.

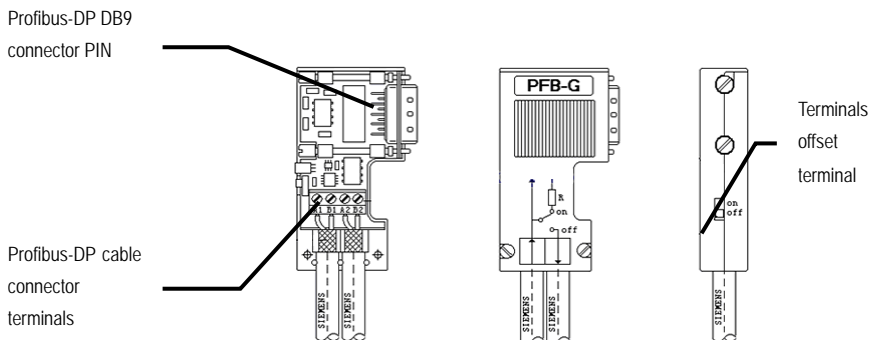

Fig 3-1, Profibus-DP Standard Connector

When PLC is chosen as Profibus-DP host and connected with 3 variable frequency inverters as slave devices, the Wiring diagram is shown in Fig 3-1.

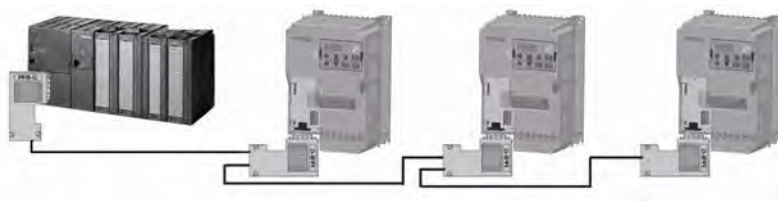

Fig 3-2 Wiring Diagram

Note:

1. Please use multi-meter to check PIN 3 (A data cable) of every connector of Profibus-DP connection is ON or not, and PIN 8 (B data cable) is ON or not. Place terminal offset resistor switch of both connecting connector to ON position (Or slide terminal switch of DP card to ON), Place terminal offset resistor switch of both connecting connector to OFF position (or slide terminal switch of DP card to OFF), please check resistor between data cable A and data cable B, it should be around 110 Ω.
2. Please be prepared for anti interference. Avoid parallel wiring for communication cable and power cable and make sure the cover of slave device and shield layer of communication cable share the same grounding. The earth terminal E of DP card should be reliably connected with earth terminal of the inverter.
3. The maximum slot is 10, which could not be exceeded.
4. For GSD documents, please visit our official website: www.veichi.com.

9.5 Appendix 5: LCD Keyboard Manual

1. Function Feature

LCD keyboard is designed for user checking function parameters more directly. Language displays in English and Chinese, compatible with other LED keyboard designed by our company.

It can display two monitoring parameters at the same time when inverter stops or runs.

There're vivid icons for states of running, stop and fault, which enables users to understand and remember states of inverter conveniently.

There're also parameter copy and download functions; parameters can be downloaded, convenient for users to change parameters in bulk.

Potentiometer on the keyboard enables users to adjust given frequency by potentiometer.

Note:

1. If special type inverter needs LCD keyboard, please contact us.
2. Users must confirm the type of LCD keyboard matches the inverter.

Software mode of LCD keyboard	Type of inverters
KB01B	AC80
KB02B	AC60,AC60B and AC100
KB03B and KB03B or above	AC60,AC60B and AC100

2. Monitor Interface

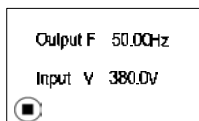

Chart 1 (a) stop state

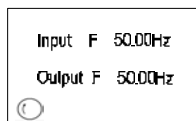

Chart1 (b) FWD running state

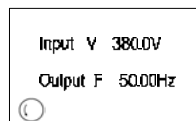

Chart1 (c) REV running state

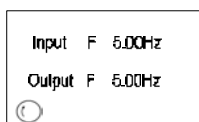

Chart1 (d) JOG FWD state

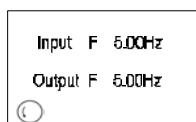

Chart1 (e) JOG REV state

See chart 1, all kinds of status interface when inverter runs or stops, displaying two monitoring parameters and status. Users can select first -line monitoring parameters by **SET**, and select second-line monitoring parameters by **<<**. (Can select one group of parameter in four groups)

3. Shortcut Menu Interface

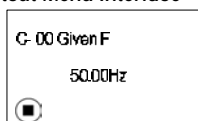

Chart 2: shortcut menu interface

Please press **PRG** key for 1s, and go into shortcut menu interface as chart 2. And users can check parameters by **▲** or **▼** key, pressing **PRG** or **SET** key to return.

4. Parameters Menu Interface

(1) First level menu interface

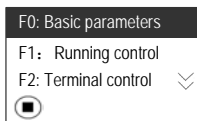

Chart 3 First level menu;

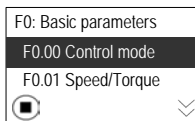

Chart 4 Second level menu;

Press **PRG** key into first level menu, and it can display three parameters. User can select anyone of them by press **▲** or **▼** key. Press **PRG** key to return back. Pressing **SET** key means selecting the item, and then return.

(2) Second level menu interface

When using AC80 series in the first level menu, press **PRG** key to go into second level menu. When using AC60 series in main menu, press **PRG** key to go into menu. displays first level menu items in first line, and displays second level menu items in second line. Position of cursor is factory default setting. Press **◀** key to replace items, Press **▲** or **▼** key to move cursor, Press **PRG** key to return, Pressing **SET** key means selecting the item, and then return.

(3) Third level menu interface

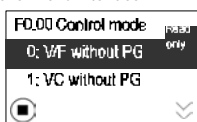

Chart 5 (a) parameter changing line

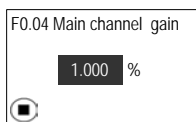

Chart 5 (b) data operation

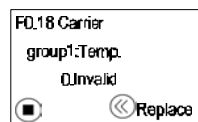

Chart 5 (c) group operation

After going into second level menu, press **PRG** key to go into third level menu. There're 3 kind of third level menu: changing line, data and group.

Changing line: First line displays second level items, second and third line display third level items, and position of cursor is factory default setting, details refer to chart 5(a).

Press **◀** key to shift parameter number;

Press **▲** or **▼** to move cursor.

Press **PRG** to return to previous interface.

Press **SET** to select item, and then return.

Data operation: First line displays second level menu items, and second line displays data, details refer to chart 5 (b).

Press **◀** to shift parameter number;

Press **▲** or **▼** to increase or decrease data while pressing **◀**. Press **▲** or **▼** to increase or decrease data from lowest bit without pressing **◀**.

Press **PRG** to return to previous interface.

Press **SET** to confirm modifying data, and then return.

Group operation: First line displays second level menu items, second line displays group number, and third line displays third level menu items, details refer to chart 5(c).

Press **◀** to change group number, Press **▲** or **▼** to change items;

Press **PRG** to return to previous interface;

Press **SET** to confirm modifying items, and then return.

If items can't be modified by pressing **▲** or **▼** in third level menu while displaying 'Read only', it means the parameter can't be modified when inverter is running or modifying is forbidden for the parameter.

5. Fault Status Interface

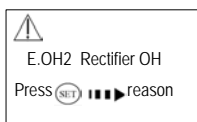

Chart 6 (a) fault

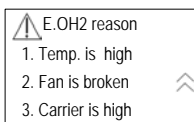

Chart 6 (b) fault reason

Fault: First line displays fault icon flashing, second line displays fault code and name, and third line reminds users of pressing **[SET]** to check fault reasons, details refer to chart 6(a). Press **[SET]** to go into fault reason. Press **[STOP]** to reset fault after fault cleared

Fault reason: First line displays fault icon, code and name, other lines display reasons, details please refer to chart 6(b). If there's up or down arrows, please press **[up arrow]** or **[down arrow]** to change page to check reasons. Press **[PRG]** or **[SET]** to return;

6. Terminal Status Interface

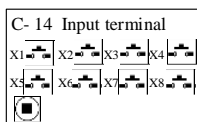

Chart 7 (a) input terminal

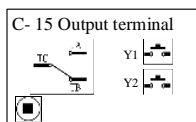

Chart 7 (b) output terminal

Input terminal: details please refer to chart(a); First line displays input terminal status, second and third lines display X1-X8 input terminals status;

Output terminal: details please refer to chart(b); First line displays output terminal status, second and third lines display Y1-Y2 output terminals status;

Note: If lines monitoring items are both in terminal state, input terminal would be displayed in priority.

7. Parameters Copy Interface

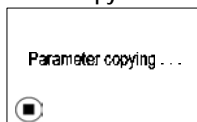

Chart8 (a) copying

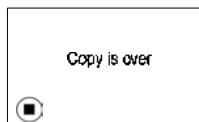

Chart8 (b) copy complete



Chart8 (c) copy fault

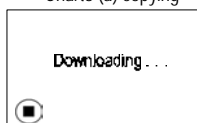

Chart8 (d) download

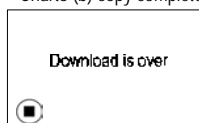

Chart8 (e) download complete



Chart8 (f) download fault

Parameter copy: details please refer to chart 8 (a),8(b),8(c)

Check F4.05 and select item "sending to keyboard from inverter", and press **[SET]**. When it displays 'completely copy', it means finishing copy operation details refer to chart 8(b). When it displays 'copy fault', it means operation is failed, details please refer to chart 8(c). Press **[PRG]** key to return.

Download same as copy

Note: Inverters must be the same series when downloading parameters

8. Motor Self -tuning Interface

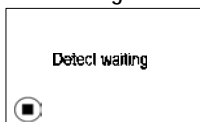

Chart 9 (a) waiting

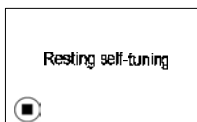

Chart9 (b) resting type self-tuning

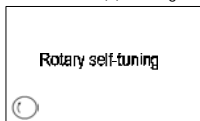

Chart 9 (c) rotary type self-tuning

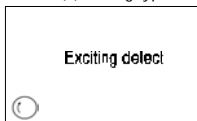

Chart 9(d) exciting magnetic detecting

Static type self-study interface: steps as chart 9 (a),(b)and(d).Please set F5.12=2,and press **SET** key to go into motor detecting waiting menu, details refer to chart 9(a).Then press **FWD** key, and it will display static self-tuning, details refer to 9(b); It displays "exciting detecting" when self-study is over, details refer to chart 9(d), and then it will return back automatically.

Rotary self-tuning: steps as chart 9 (a),(c),and (d). Please set F5.12=1,and press **SET** key to go into motor detecting waiting menu, details refer to chart 9(a).Then press **FWD** key, and it will display static self-study, details refer to 9(b); when self-study is over, it displays rotary self-study, details refer to chart9(c).After rotary self-study over, it displays exciting detecting, details refer to chart 9(d), then it will return automatically.

9. Other Menus



Chart 10 (a) keyboard locked

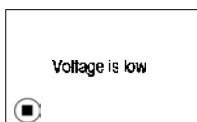

Chart10 (b) low voltage

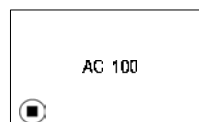

Chart 10 (c) model of inverter

Keyboard locked interface: as chart 10(a).Keyboard will display locked menu when going into next menu, after users setting password and selecting parameter locked function. Please type correct password and then go into next menu.

Low voltage interface: as chart10 (b).When input voltage is low, it will display this warning.

Model of inverter: as chart10(c).When power on, if communication is normal, it will display this menu; if power off, it will display keyboard connection fault.

9.6 Appendix VI: CAN Card Manual

CANopen communication expansion card has the following characteristics:

- 1, support the heartbeat protocol, the master can use this function to query the device status;
- 2, there're 2 send DO channels and 2 receive PDO channels supporting PDO synchronous transmission type;
- 3, SDO only supports expedited transfer mechanism with a maximum transmission of 4 bytes;
- 4, TPDO, RPDO, SDO and other communications objects COB-ID are associated with the device ID, set within the software without modification when using;
- 5, does not support emergency objects, electrical parameters of CANopen communication comply with international standards.

1. Installation of CANOPEN Card

CANOPEN card is embedded in the inverter and be sure to disconnect the power supply before installation. Installation is shown as below:

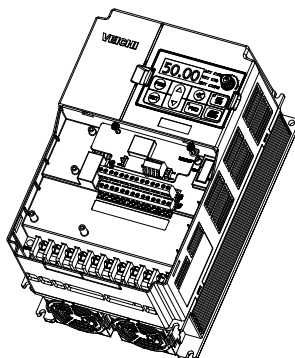

CANOPEN Card Installation Mode

2. CANOPEN Card Interface Specification

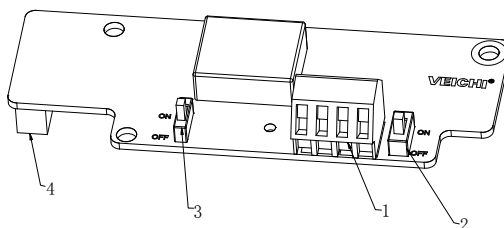

Product Interface

Mark 1: CANOPEN card interface terminal, from left to right CANG, PE, CANH, CANL;

Mark 2: The internal terminal resistor selection DIP switch;

Mark 3: Connect to the inverter earth selection DIP switch;

Mark 4: CANOPEN card and AC100 inverter interfaces;

3. CANOPEN Connection Mode

CANopen wiring mode of VEICHI inverter needs expansion card CAN01. Connector is the way of terminal, and 120Ω termination resistor must be added at the beginning and the end of the whole serial network.; shielded twisted pair wire

or special CAN communication lines should be used; wiring as shown below:

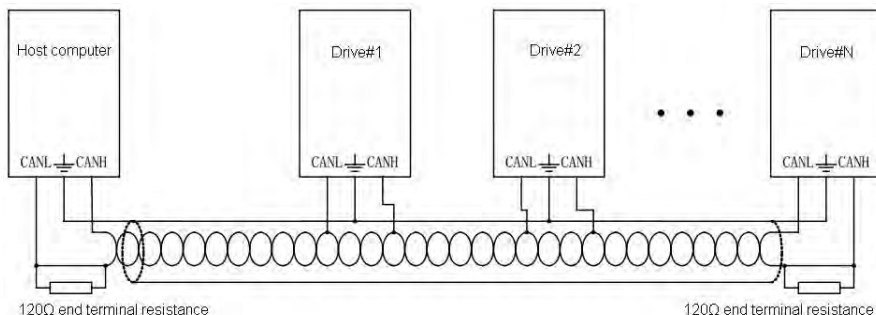

4. CANOPEN card control drive mode

the control of the drive through CANOPEN can be implemented according to the following steps (example. AC100).

- 1) wiring connection (reference CANopen wiring).
- 2) Set running command channel: drive parameter setting F0.02 = 3 (optional card).
- 3) Set frequency Source: drive parameter setting F0.03 = 10 (optional card).
- 4) Set the CANopen station: CANOPEN protocol can be set by the drive parameters Fd.11 = 0, Fd.12 set CANopen station number (range 1-127, 0 is the Disable CANopen slave function).
- 5) Set CANopen rate: the rate can be set via the LED "00" of CANopen drive parameters Fd.02.

CANOPEN communication control parameter group address description:

Function	Index	Sub index	Data specification	R/W features		
Communication given frequency	0x2030 or 0x2020	0x01	0~32000 Corresponding to 0.00Hz~320.00Hz	W/R		
Communication command setting	0x2030 or 0x2020	0x02	0000H: no order	W/R		
			0001H: FWD running			
			0002H: REV running			
			0003H: FWD JOG			
			0004H: REV JOG			
			0005H: DEC to stop			
			0006H: free stop			
Inverter state	0x2030 or 0x2020	0x03	Bit0	0: stop	1: running	R
			Bit1	0: Not ACC	1: ACC	
			Bit2	0: Not DEC	1: DEC	
			Bit3	0: FWD	1: REV	
			Bit4	0: Normal	1: Fault	
Inverter fault	0x2030	0x04	Current fault code(see fault code list)	R		

code	or 0x2020			
Communication given upper frequency limit	0x2030 or 0x2020	0x05	0~32000 corresponding to 0.00Hz~320.00Hz	W/R
Communication torque setting	0x2030 or 0x2020	0x06	0~1000 corresponding to 0.0~100.0%	W/R
Torque control FWD Max frequency limit	0x2030 or 0x2020	0x07	0~1000 corresponding to 0.0~100.0%	W/R
Torque control REV Max frequency limit	0x2030 or 0x2020	0x08	0~1000 corresponding to 0.0~100.0%	W/R
Communication given PID setting	0x2030 or 0x2020	0x09	0~1000 corresponding to 0.0~100.0%	W/R
Communication given PID feedback	0x2030 or 0x2020	0x0A	0~1000 corresponding to 0.0~100.0%	W/R
Voltage frequency differential voltage setting	0x2030 or 0x2020	0x0B	0~1000 corresponding to 0.0~100.0%	W/R

5. CANopen Supporting Index List

Parameter index Group member is regular corresponding; as follows:

Index = 2000H + Group

Sub index= member+1

Example: setting for F3.22.

Group -member

F3 (F3H) - 22(16H)

Index = 2000H + 03H = 2003H

Sub Index = 16H + 1H = 17H

AC100 corresponding parameters:

Function code	CanOpen Index and Sub-index
F0.00 --- F0.30	0x2000.0x01 --- 0x2000.0x1F
F1.00 --- F1.36	0x2001.0x01 --- 0x2001.0x25
F2.00 --- F2.75	0x2002.0x01 --- 0x2001.0x4C
F3.00 --- F3.52	0x2003.0x01 --- 0x2003.0x35
F4.00 --- F4.16	0x2004.0x01 --- 0x2004.0x11
F5.00 --- F5.42	0x2005.0x01 --- 0x2005.0x2B

F6.00 --- F6.57	0x2006.0x01 --- 0x2006.0x3A
F7.00 --- F7.12	0x2007.0x01 --- 0x2007.0x0D
F8.00 --- F8.46	0x2008.0x01 --- 0x2008.0x2F
F9.00 --- F9.19	0x2009.0x01 --- 0x2009.0x14
FA.00 --- FA.44	0x200A.0x01 --- 0x200A.0x2D
FB.00 --- FB.22	0x200B.0x01 --- 0x200B.0x17
FC.00 --- FC.55	0x200C.0x01 --- 0x200C.0x38
FD.00 --- FD.13	0x200D.0x01 --- 0x200D.0x0E
FE.00 --- FE.21	0x200E.0x01 --- 0x200E.0x16
FF.00 --- FF.41	0x200F.0x01 --- 0x200F.0x2A
C-01 --- C-68	0x2021.0x01 --- 0x2021.0x45
Communication control parameter address	0x2030.0x01 --- 0x2030.0x0C

Warranty Card

Profile

User Name : _____

Address : _____

Contacts : _____ Phone : _____ Fax : _____

Model : _____ Machine Code : _____

Agent/Distributor Profile

Delivery Company : _____

Contacts : _____ Phone : _____ Delivery Date : _____

Warranty Clauses

The Company solemnly states that since the day users purchase from my company (hereinafter referred to as manufacturer),they can enjoy the following warranty services;

- 1.Since the date of purchase, users can enjoy the following warranty services of the product:
 - 1) Within 30 days after shipment,the company promises returning,replacement and maintenance of the product.
 - 2) Within 90 days after shipment,the company promises replacement and maintenance of the product.
 - 3) Within 18 months after shipment,the company promises only maintenance of the product.
 - 4) Products exported to countries except China shall not enjoy the warranties mentioned above.
2. Since the date of purchase, users can enjoy the service of the company when they pay for the service.
3. Exception Clauses: Product failures caused by the following reasons would not enjoy the free warranty services of the manufacturer:
 - 1) Failures caused by operations of users that is not operated in accordance with the requirements of the product manual;
 - 2) Failures caused when users repair or renovate the product without communicating with the manufacturer in advance;
 - 3) Failures caused by abnormal aging of the product resulted from poor using environment;
 - 4) Failures caused by earthquake, fire or other natural disasters or abnormal voltage;
 - 5) Failures caused by damage during transportation(mode of transportation is decided by users and the company only helps to handle cargo shipment procedures).
4. In the following conditions, the manufacturer have the right not to provide warranty services:
 - 1) When the marks,trademarks or nameplates of the products are destroyed or can not be identified;
 - 2) When users do not pay for the product according to signed contract;
 - 3) When users intentionally hiding the improper operations during installation, wiring and maintenance;
5. For products that enjoy all returning,replacement and maintenance services, first the product should be returned to the company and after responsibility confirmation,the product can be replaced or repaired.

Certificate of Approval

QC check : _____



The product has been checked and proved to be qualified for delivery in conformity with standard.